

Item No.:FJ308
Version No.:FJ308-V01

FreeWing M^{DEL}
www.sz-freewing.com

F-14 Tomcat User Manual

Wingspan : 1550mm

EN 1 ~ 13

中 14 ~ 26



  
MADE IN CHINA

Introduction

Thank you for purchasing F-14 "Tom Cat" dual 80mm ducted based fighter model! Grumman for the US Navy designed and manufactured F-14 "Tom Cat", no doubt, is the majority of military fan favorite carrier-based fighter in the US Navy's fighter group. In addition to its cool and beautiful appearance, unique design of variable-sweep wings beyond these features, powerful combat is another focus, which mount "Phoenix" missile, the strategic imagination became reality! Although, F-14 "Tom Cat" this legendary fighter has bid farewell to the sky and the sea! However, it did not affect us to continue on the "Tom Cat" praise and love!

We obtained the North American Grumman authorization and designed it refer to F-14 "Tom Cat" D-type prototype! Whether it is the overall shape of the model, painting, or the nose portion of the pitot tube, all kinds of antennas, weapons pylons, missiles and other details, its vivid.

Scale is not our only pursuit, variable sweep flight is our pursuit for F-14. We use the electric worm and alu-frame to achieve the variable sweep flight. After thousands test and dozens of improvements, we solved the flight un-stability problem in swept wing flight. Although we only set up two fixed angle swept wing, we can fully appreciate that the variable sweep wing bring us its flight pleasure. In forward wing flight, F14 is very stale to fly. In swept wing flight, it looks like change a new jet, flight speed is quicker and more flexible, it feels like that you controlled one upper wing trainer firstly, and suddenly change to fly a jet , full of excitement!

F-14 is a complicated model plane, We strongly recommend that you read the manual very carefully before install, and adjust it according to manual parameter. We wish you have a successful maiden flight and hope to give you a new flying experience!

⚠ NOTE: This is not a toy. Not for children under 14 years. Young people under the age of 14 should only be permitted to operate this model under the instruction and supervision of an adult. Please keep these instructions for further reference after completing model assembly.

Note

1. This is not a toy! Operator should have a certain experience, beginners should operate under the guidance of professional players.
2. Before install, please read through the instructions carefully and operate strictly under instructions.
3. Cause of wrong operation, Freewing and its vendors will not be held responsible for any losses.
4. Model planes' players must be on the age of 14 years old.
5. This plane used the EPO material with surface spray paint, don't use chemical to clean, otherwise it will damage.
6. You should be careful to avoid flying in areas such as public places, high-voltage-intensive areas, near the highway, near the airport or any other place where laws and regulation clearly prohibit.
7. You cannot fly in bad weather conditions such as thunderstorms, snows....
8. Model plane's battery, don't allowed to put in everywhere. Storage must ensure that there is no inflammable and explosive materials in the round of 2M range.
9. Damaged or scrap battery should be properly recycled, it can't discard to avoid spontaneous combustion and fire.
10. In flying field, the waste after flying should be properly handled, it can't be abandoned or burned.
11. In any case, you must ensure that the throttle is in the low position and transmitter switch on, then it can connect the lipo-battery in aircraft.
12. Do not try to take planes by hand when flying or slow landing process. You must wait for landing stop, then carry it.

Important additional notes

The Y-type clevis used in this product is equipped with a transparent silicone ring for secondary reinforcement, which can effectively prevent the clevis from accidentally loosening.

As shown in the following figure, when you buckle the clevis into the control surface horn, use the silicone ring to cover the clevis.

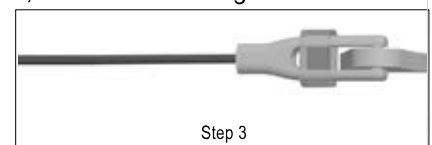
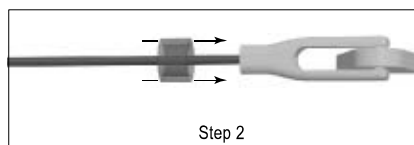
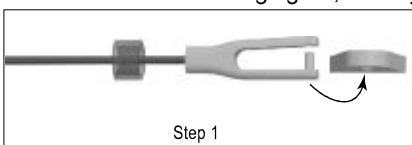

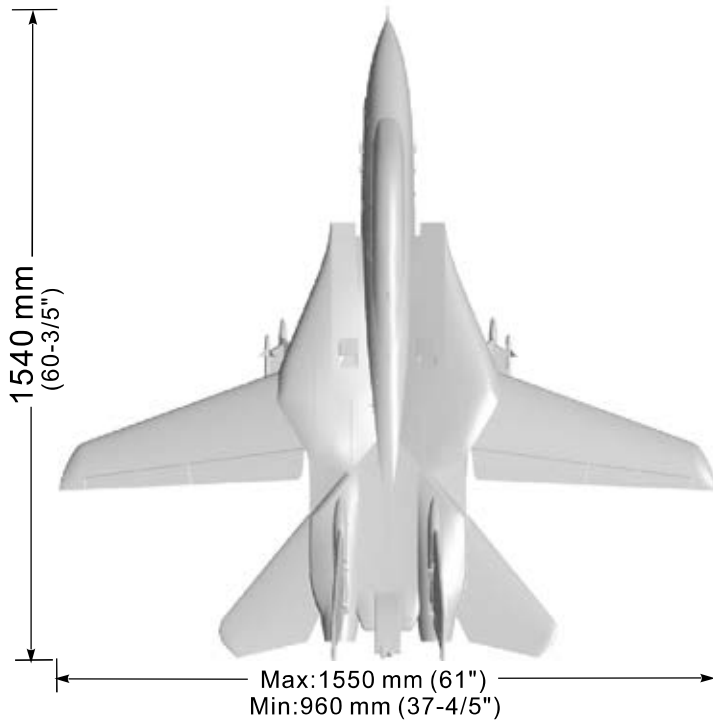

Upgrade Version

- Wingload : 255g/dm²
- Motor: O/R BL 3530-1680KV (2pcs)
- Servo: 9g Hybrid servo (2pcs)
- 17g/23 MG servo (6 / 2pcs)
- ESC: 80A with 8A UBEC (2pcs)
- Ducted fan: 80mm 12-blade fan (2pcs)
- Weight: 4340g (w/o Battery)
- Thrust: 5400g

General function

- New electric retract landing gear (Large torque)
- Nose landing gear cabin door
- Scale high LED light set, nose take-off light
- Wing sweep controller
- Hardware
- Aluminum rear hub (with bearings)
- Scale cockpit, pilot

Package list



Open package and check the package list. (Different version include different contents) Include ✓ Optional ● Not include ✕

NO.	Parts Name	PNP	KIT Plus	KIT	NO.	Parts Name	PNP	KIT Plus	KIT
1	Fuselage	✓	✓	✓	12	EDF	✓	✕	✕
2	Main wing	✓	✓	✓	13	ESC	✓	✕	✕
3	Elevator	✓	✓	✓	14	Battery	●	●	●
4	Rudder	✓	✓	✓	15	Fin	✓	✓	✓
5	Nose cone	✓	✓	✓	16	Plastic part	✓	✓	✓
6	Missiles and pylons	●	●	●	17	Screw bag	✓	✓	✓
7	Retract landing gear	✓	✓	✓	18	Pushrod ,clevis	✓	✓	✓
8	LED light	✓	✓	✓	19	Hardware	✓	✓	✓
9	Wing sweep controller	✓	✓	✓	20	Carbon tube	✓	✓	✓
10	Servo	✓	✓	✕	21	Glue	✓	✓	✓
11	Motor	✓	✕	✕	22	Manual	✓	✓	✓

Fuselage

Install front and rear fuselage

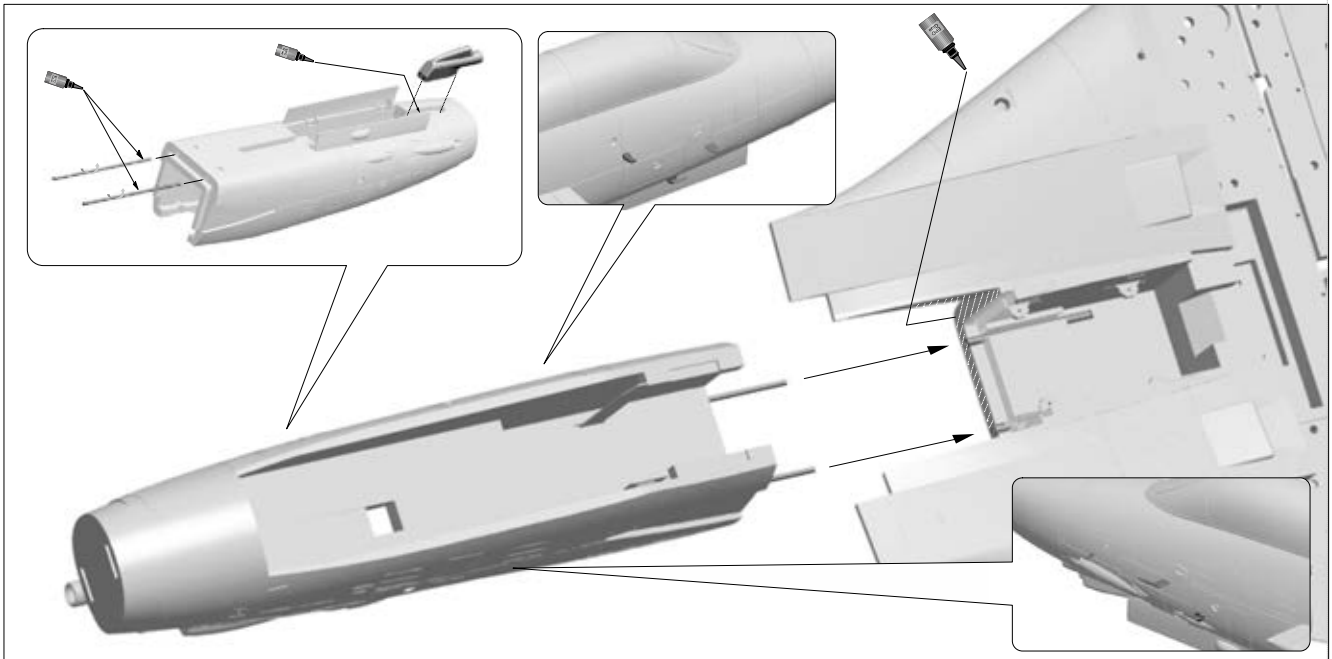

Rudder

Install rudder servos

1. Use servo tester or radio to center the servo arm.
2. Use glue to attach the 17g servo box (C) and rudder horn (D) on the rudder.
3. Install the servo on the 17g servo box (C), and press the servo cable on the servo cable trough (F), cover the 17g servo cover (B), and use 2pcs screws (A) to fix the servo.
4. Use rudder pushrod (E) to connect the servo arm and rudder horn (D).

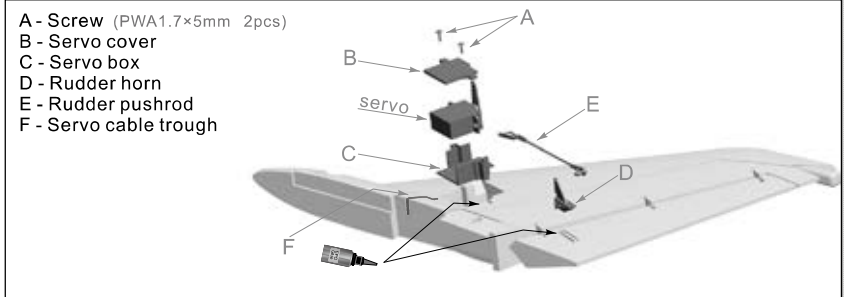

Rudder pushrod size

Pushrod diameter : Ø 1.5 mm

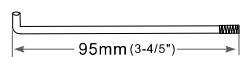

Rudder pushrod mounting hole



Install rudder

- A - Screw (PA3x8mm 8pcs)
- B - Extension cable of servo, LED light
- C - Servo, LED light cable
- D - Rudder

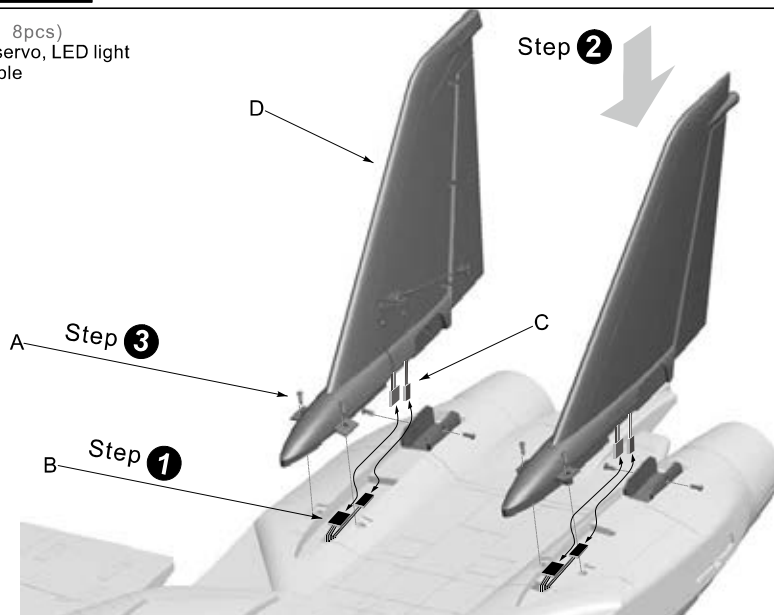

Elevator

Install elevator servos

1. Use servo tester or radio to center the servo arm.
2. Use screw (A) to fix servo (B) on the elevator servo mount (C).
3. As the right photo shown, press the servo cable on the servo trough, then put on the cable compartment.
4. Repeat the above steps to install on the other side servo.

Elevator pushrod size

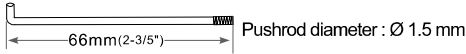

Elevator pushrod mounting hole

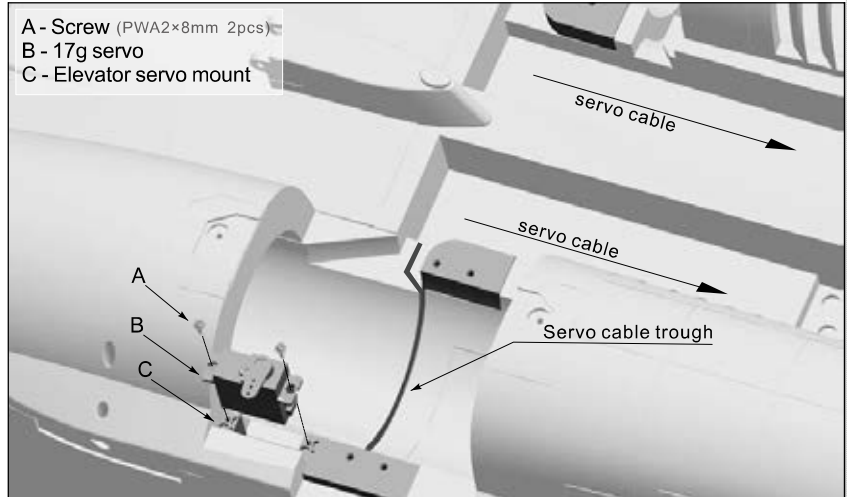

Install Elevator

- A - Screw (PA2.3x6mm 4pcs)
- B - Elevator metal horn
- C - Screw (Fm2x10mm 2pcs)
- D - Nut (M2mm 2pcs)
- E - Elevator rotating shaft
- F - Screw (PM2x4mm 2pcs)
- G - Elevator fixed ring
- H - Elevator pushrod
- I - Screw (PT3x8mm 4pcs)

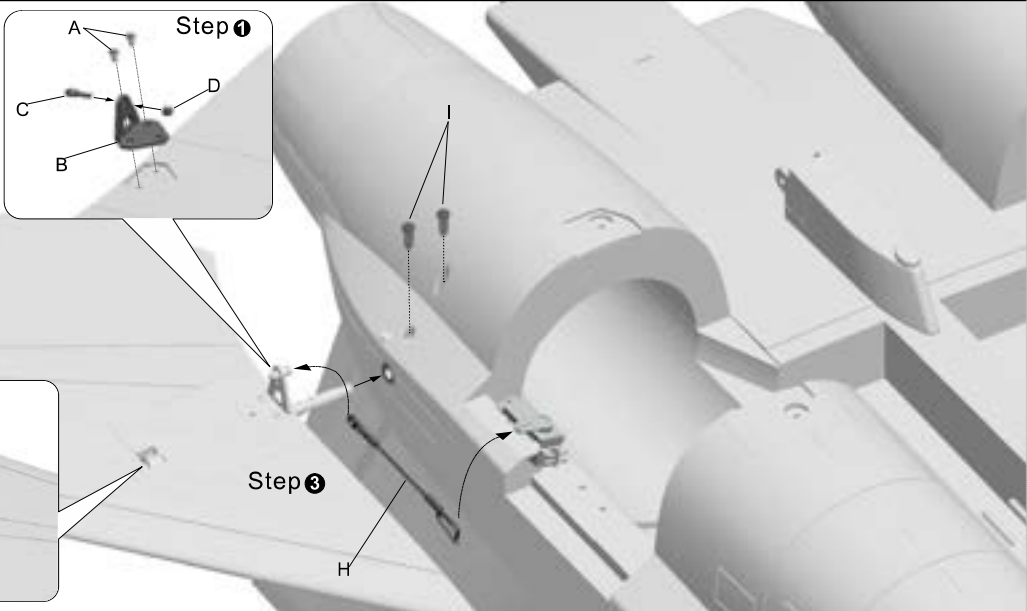
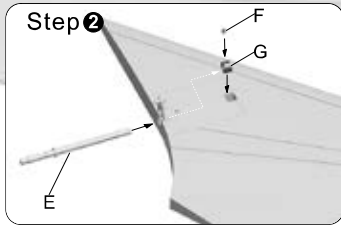
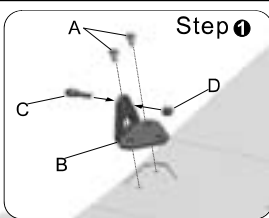

Note: when use screw I to fix the elevator rotating shaft, we need to control the screw depth, make sure the screw reach to the notch position of elevator rotating shaft, also make sure the elevator rotate smoothly. We can try to pull out the elevator to test the screw reach to the correct depth or not.

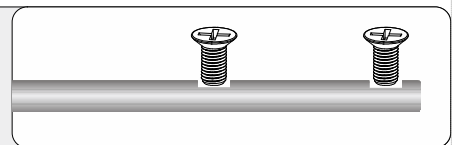

Main Wing

Install Main Wing Servo

1. Use servo tester or radio to center the servo arm.
2. Use glue to attach the 17g servo box (C) and horn (D) on the main wing.
3. Install the servo on the 17g servo box (C), and press the servo cable on the servo cable trough (F), cover the 17g servo cover (B), and use 2pcs screws (A) to fix the servo.
4. Use Pushrod (E) to connect the servo arm and rudder horn (D).

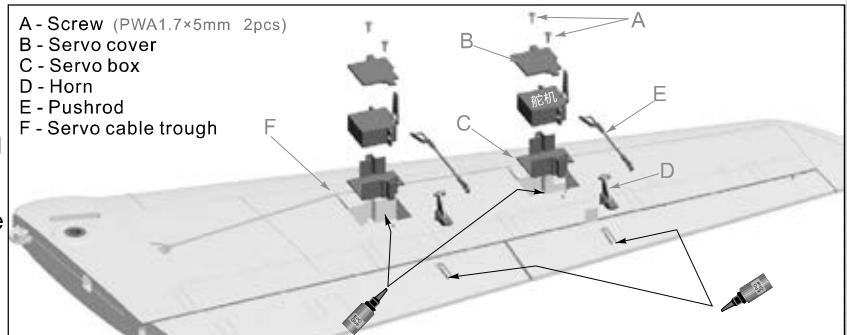

Aileron pushrod size



Flap pushrod size

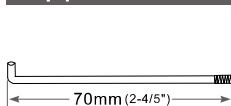

Flap pushrod mounting hole

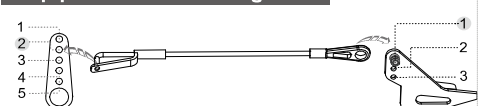

Aileron pushrod mounting hole



Install Variable Sweep Wing

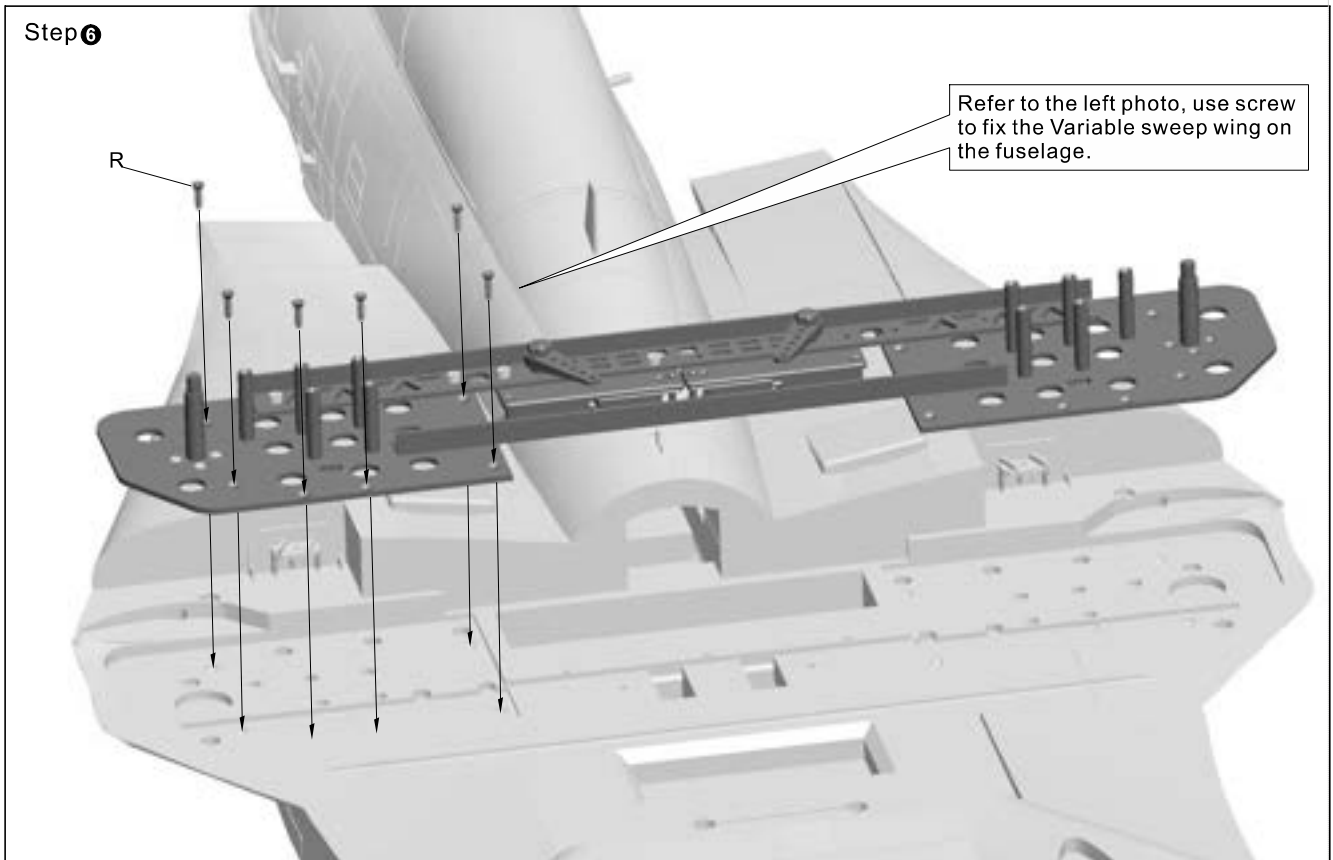
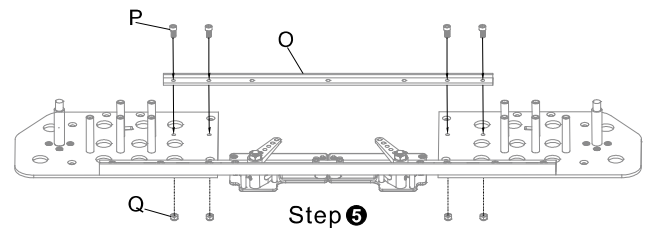
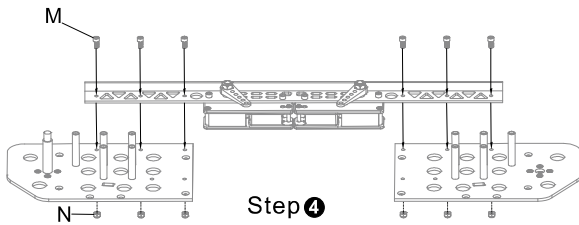
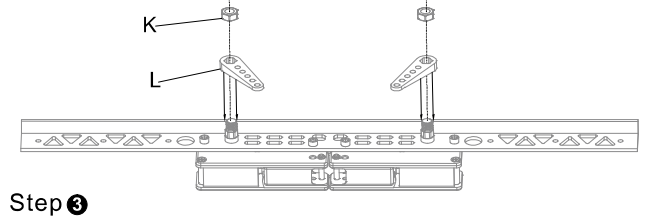
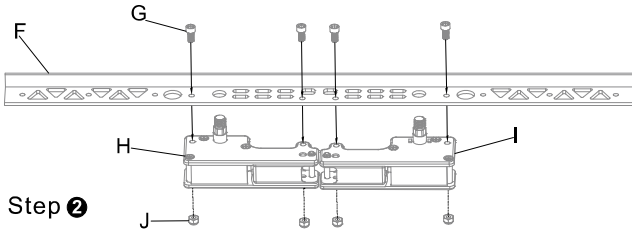
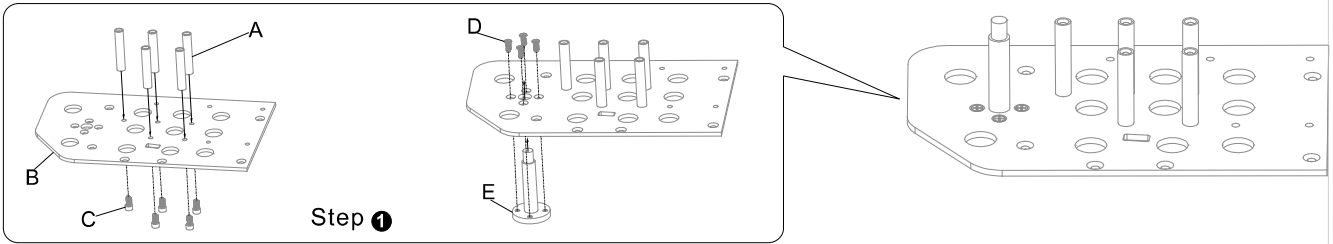

- A-Sweep Wing supported rod
- B-Sweep Wing mounting plate
- C-Screw (HM3×6mm 10pcs)
- D-Screw (KM2.5×6mm 8pcs)
- E-Rotating shaft
- F-Stiffener(F)

- G-Screw (HM3×8mm 4pcs)
- H-Wing sweep controller left
- I-Wing sweep controller right
- J-Locknut (M3 4pcs)
- K-Screw (M6 4pcs)
- L-Arm

- M-Screw (HM3×8mm 6pcs)
- N-Locknut (M3 6pcs)
- O-Stiffener(B)
- P-Screw (HM3×8mm 4pcs)
- Q-Locknut (M3 4pcs)
- R-Screw (KA3×12mm 12pcs)

Install Fuselage

EN

Install main wing

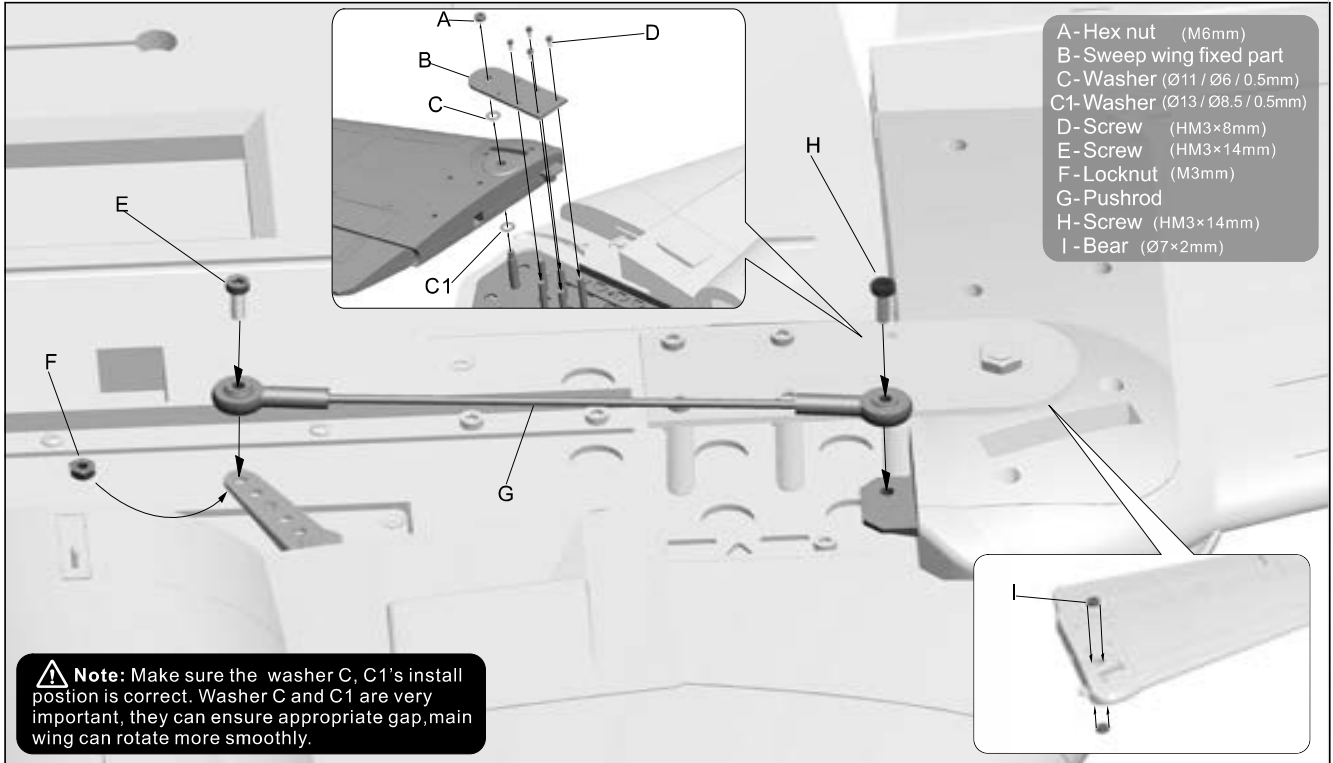

NOTE :

1. When install the Sweep Wing supported rod, please make sure the metal arm of wing sweep controller is in correct angle. In factory, we adjusted the metal arm of wing sweep controller is in forward wing condition. (In forward wing condition, the main wing angle is 20 degree.) If not correct angle, the arm of wing sweep controller will operate in wrong direction, and make damage.
2. In F14 forward wing condition, the wing angle is 20 degree. Through wing sweep controller adjusted, the max angle it can reach to 65 degree. We can limit the max angle to 45 degree through revise the installation hole of wing sweep controller arm.
3. In flight, when main wing is in swept wing condition, don't use flap. It will cause the damage of flap and flap servo. Flap only use for forward wing condition.

Sweep wing angle correction and setting

Metal arm and ball head position ①

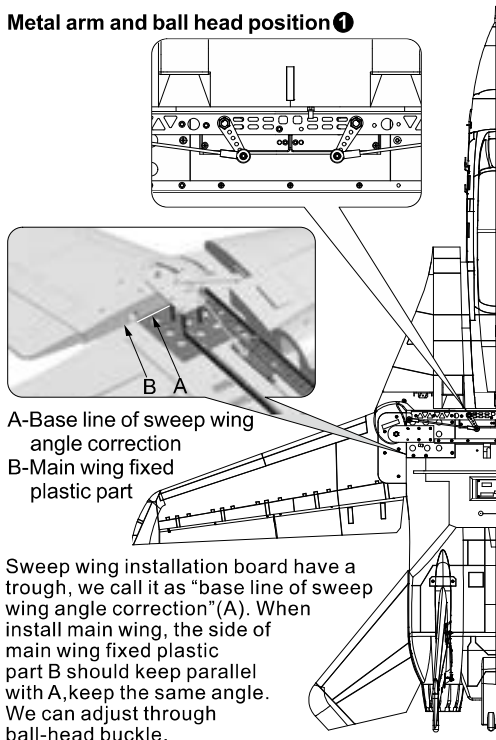

Mear arm and ball head position ②

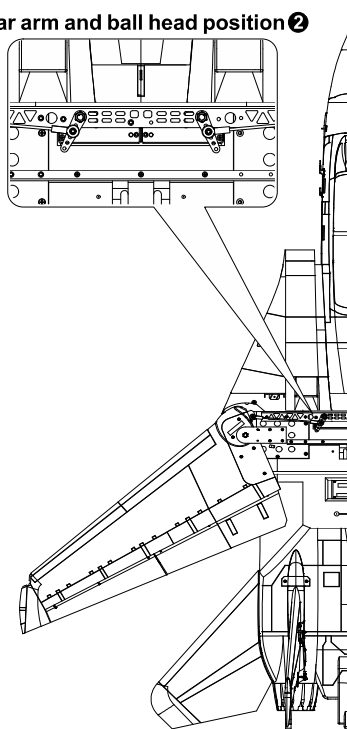

Mear arm and ball head position ③

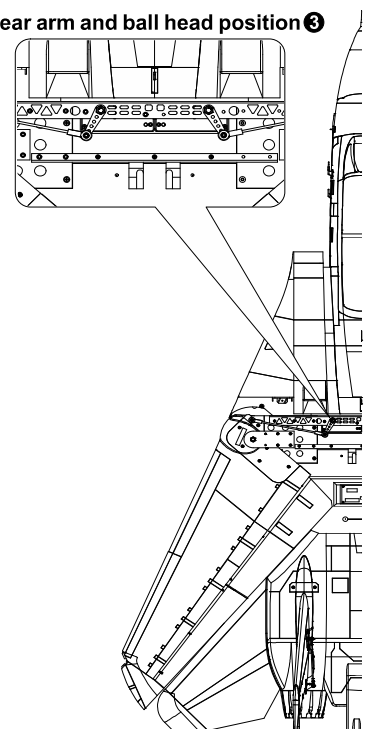

Forward wing angle 20 degree

Swept wing angle 41 degree

Swept wing angle 62 degree

F-14 Tomcat

Item No.: FJ308
Version No.: FJ308-V01

Install main wing

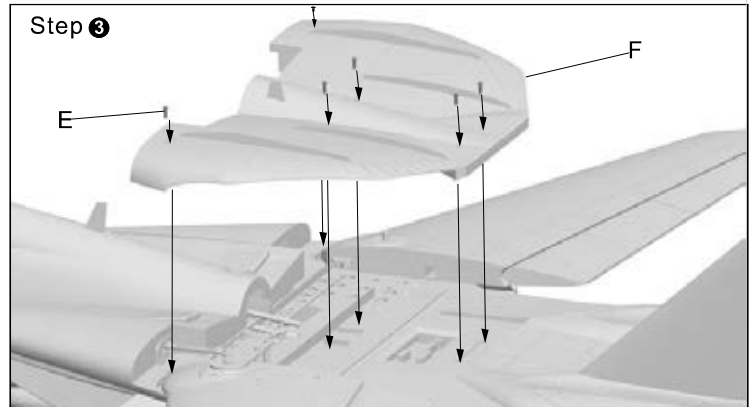
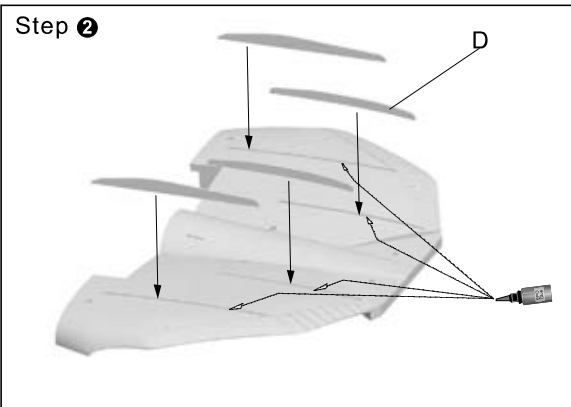
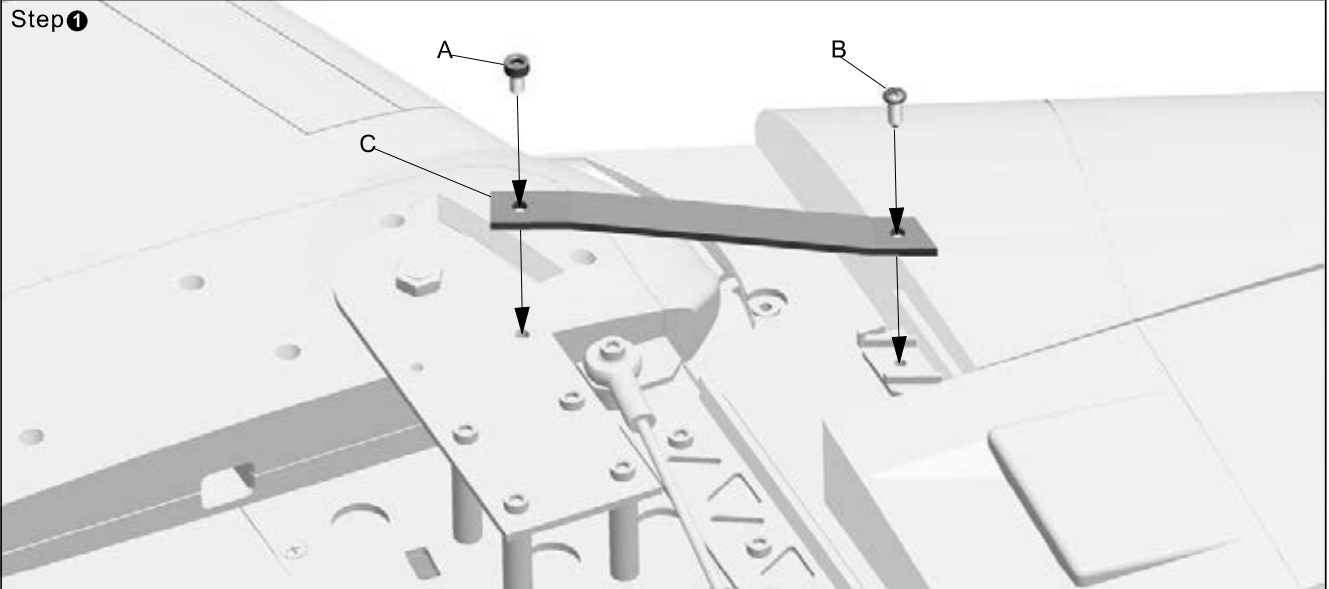

- A-Screw (HM3×8mm)
- B-Screw (PWA3×12mm)
- C-Mainwing strengthen connecting rod (L/R)
- D-Wing fence
- E-Screw (PA3×10mm / PA3×25mm)
- F-Sweep wing structure foam cover

- ① -After adjust the main wing, use screw to fix the main wing strengthen connecting rod, reinforce main wing of the anti-distortion tolerance.
- ② -Use glue to attach the wing fence on the surface of sweep wing structure foam cover.
- ③ -Use screw to fix the sweep wing structure foam cover.

Install missiles and pylons

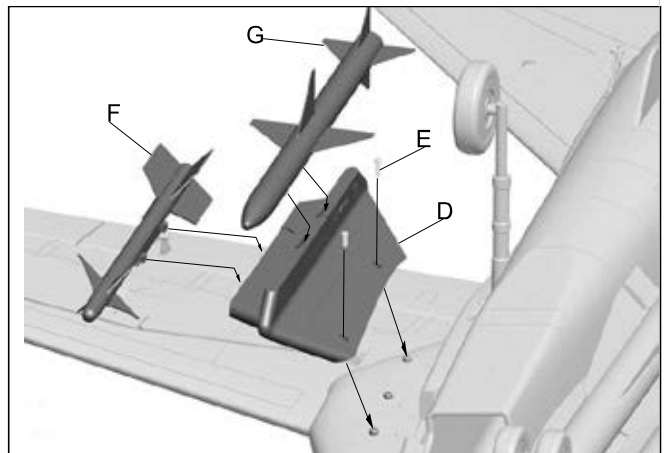
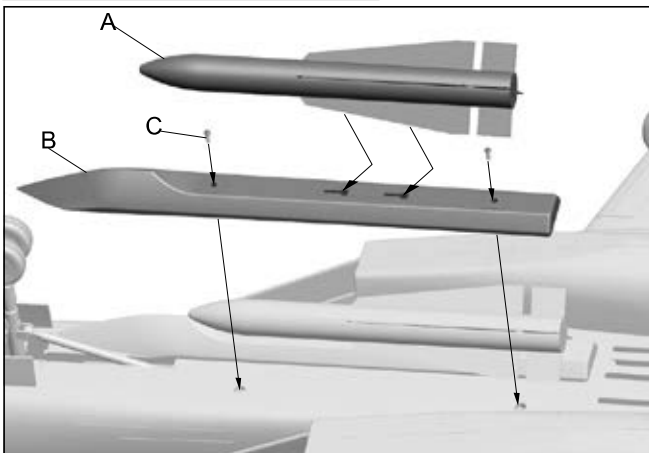

- A-AIM-54 missile
- B-Pylon
- C-Screw (PA3×8mm)
- D-Composite pylon
- E-Screw (PA3×8mm)
- F-AIM-9 missile
- G-AIM-7 missile

1. Use screw to fix the two types pylons.
2. Lock the missiles on the plastic fixed trough of pylons, move forward to the arrow direction, lock tightly.

Install landing gear

EN

Nose Landing Gear Assemble

Please assemble, disassemble the nose landing gear according to the following photo.

Accessories name and specification

- | | | |
|--|-----------------------------------|-----------------------------------|
| A -Retract controller | H -O-shape connecting arm | O -Plastic supporting rod |
| B -Nose gear main rod | I -LED light fixed arm | P -8-shape connecting arm |
| C -Nose gear steering arm | J -LED light | Q -U-shape plastic connecting arm |
| D -Nose gear steering control ring | K -Nose wheel axle | R -Jimi screw (M3×3mm) |
| E -Nose gear steering rod | L -Wheel (Ø45×16mm) | S -Screw (PM2×3mm) |
| F -Nose gear shock absorber active rod | M -Washer | T -Screw (PM2×4mm) |
| G -Spring | N -Nose gear slant supporting rod | U -Jimi screw (M4×4mm) |
| | | V -Screw (PA2×8mm) |
| | | W -Pin (Ø3.5×9.2mm) |
| | | X -E-buckle (id Ø2.0mm) |
| | | Y -E-buckle (id Ø1.5mm) |
| | | Z -Pin (Ø2×11.1mm) |

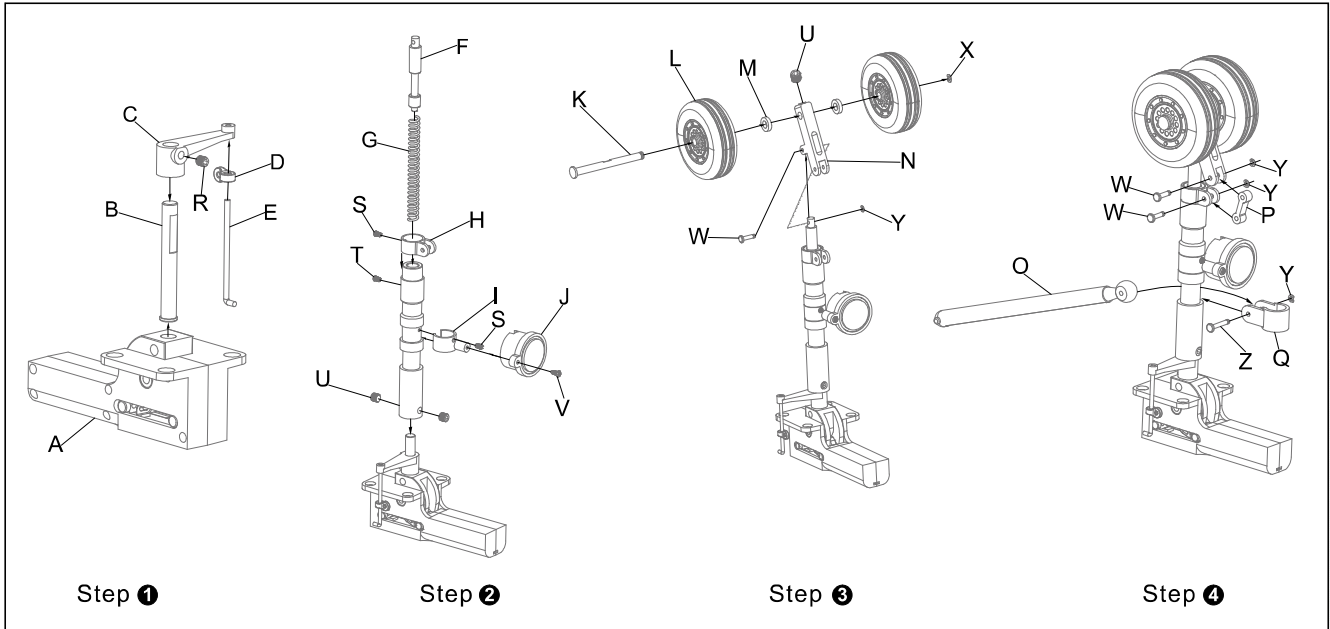

Install nose steering servo, cabin door

Please refer to the following photo to install, replace/revise nose gear cabin door.

Accessories name and specification

- | | |
|--------------------------|---------------------------------------|
| A -Plastic guide track | E -Screw (PWA2×8mm) |
| B -Screw (PWA3×12mm) | F -Left side cabin door of nose gear |
| C -9g servo | G -Right side cabin door of nose gear |
| D -Nose steering pushrod | H -Cabin pushrod |

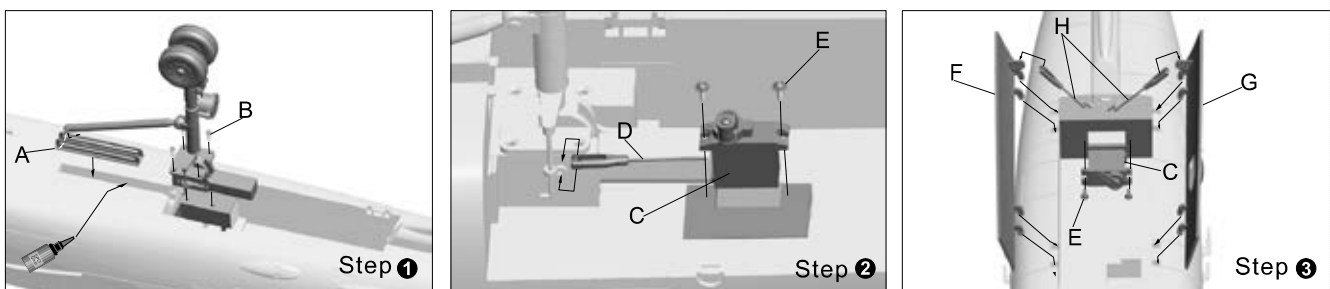

<p>Nose steering pushrod size</p> <p>Pushrod diameter : Ø 1.2mm</p>	<p>Servo pushrod installing hole</p>
<p>Cabin door pushrod size</p> <p>Pushrod diameter : Ø 1.0mm</p>	<p>Servo pushrod installing hole</p>

Install landing gear

Rear Landing Gear Assemble

Please assemble, disassemble the rear landing gear according to the following photo.

Accessories name and specification

- A -Retract controller
- B -Jimi screw (M4×4mm)
- C -Rear gear main rod
- D -Jimi screw (M4×4mm)
- E -Rear gear main supporting rod
- F -Rear wheel axle
- G -Wheel (∅60×17mm)
- H -Washer
- I -Rear gear shock absorber active rod
- J -Spring
- K -Spring guide post
- L -Spring
- M -Screw (M3×5.2mm)
- N -Screw (PWA3×12mm)
- O -Rear gear blister piece (left/right)

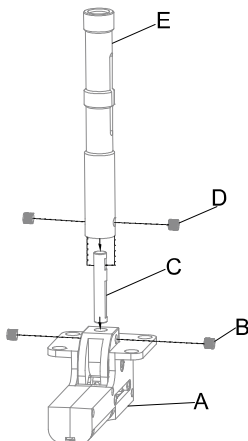
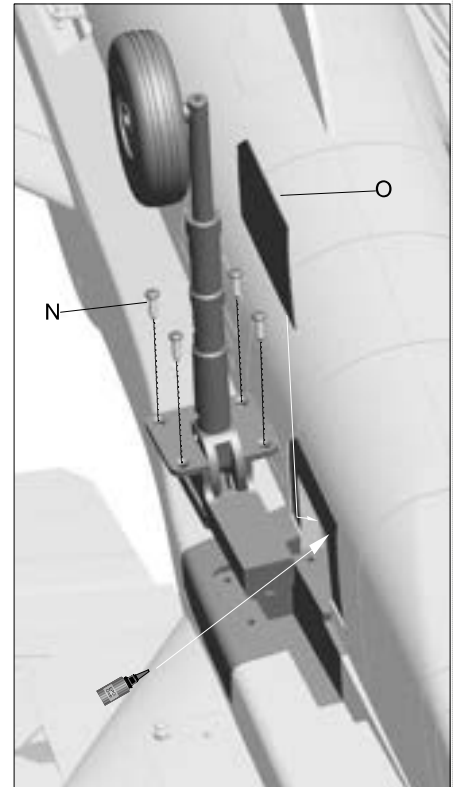
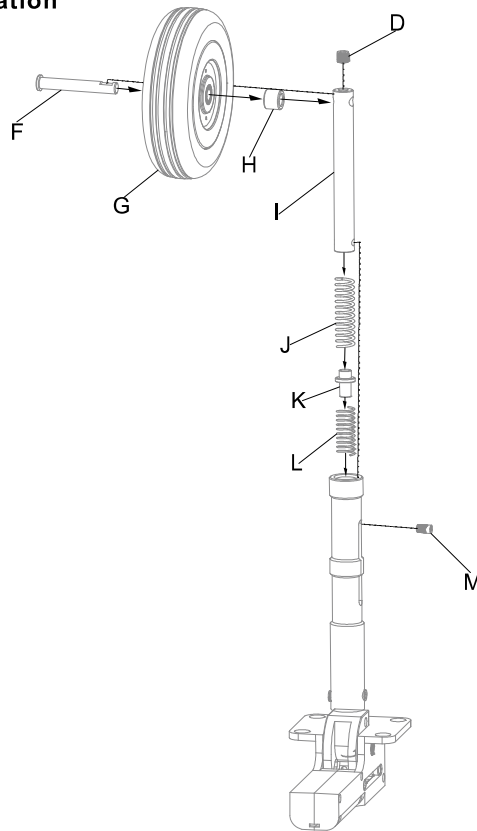

Step ①

Step ②

Step ③

Servo Introduction

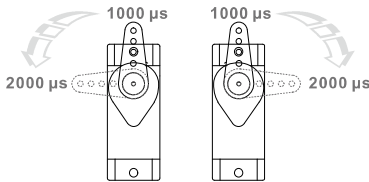

The servo positive or reverse rotation is defined as follows:
 When servo input signal change from 1000µs to 2000µs,
 The servo arm is rotated clockwise, its positive servo.
 The servo arm is rotated counterclockwise, its reverse servo.

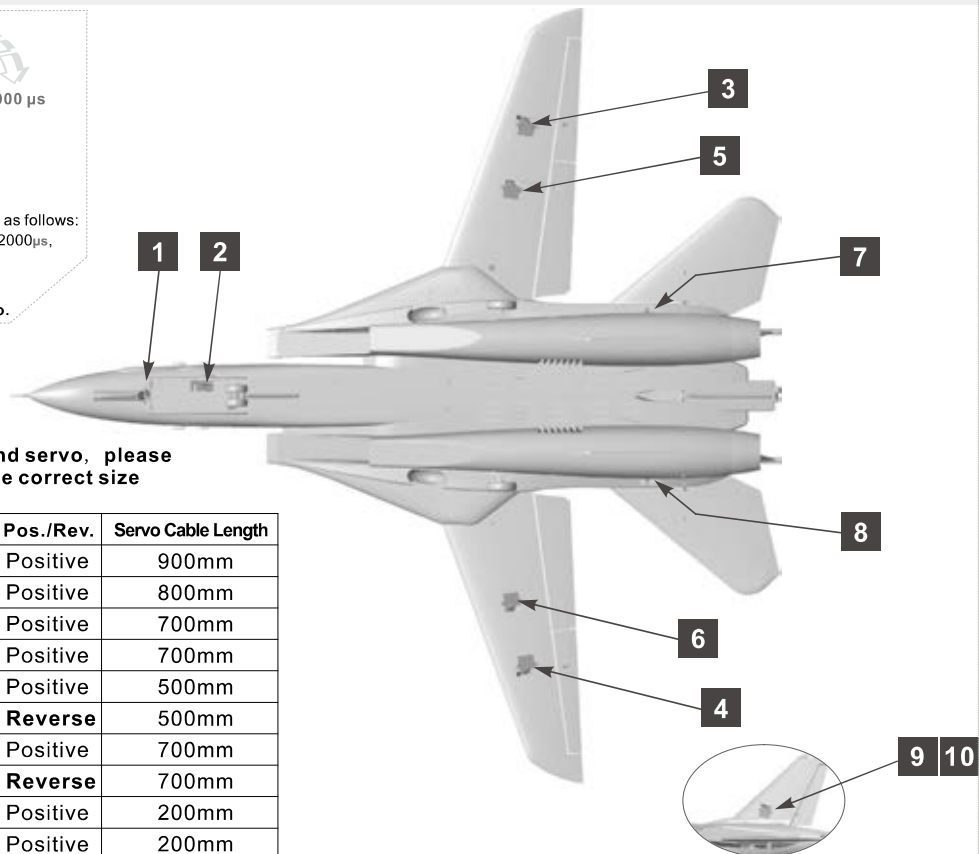

If you need to purchase other brand servo, please refer to the following list to choose correct size servo.

Installing position	No.	Pos./Rev.	Servo Cable Length
Front cabin door (9g Hybrid)	1	Positive	900mm
Nose gear steering (9g Hybrid)	2	Positive	800mm
Aileron(L) (17g MG)	3	Positive	700mm
Aileron(R) (17g MG)	4	Positive	700mm
Flap(L) (17g MG)	5	Positive	500mm
Flap(R) (17g MG)	6	Reverse	500mm
Elevator(L) (23g MG)	7	Positive	700mm
Elevator(R) (23g MG)	8	Reverse	700mm
Rudder(L) (17g MG)	9	Positive	200mm
Rudder(R) (17g MG)	10	Positive	200mm

F-14 Tomcat

Item No.: FJ308
 Version No.: FJ308-V01

Motor Specification

EN

#MO035305
3530-1680KV

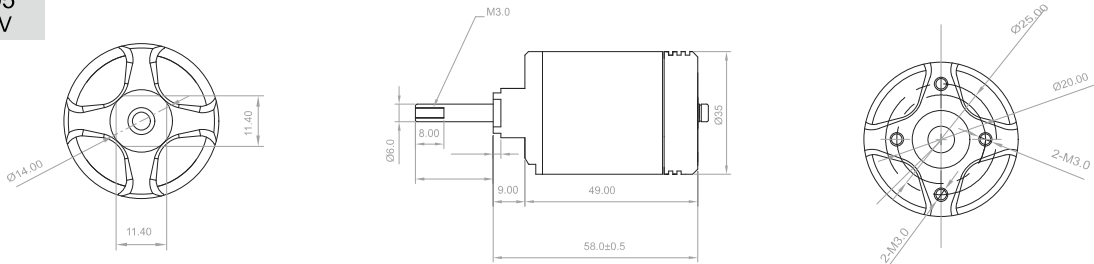

Unit: mm

Item No.	Fan size	Motor specifications	Voltage (V)	Current (A)	Max power (W)	Thrust (g)	Efficiency (g/w)	Speed (rpm)	Weight (g)
E7238	80mm 12-Blade	3530-1680KV	22.2	70	1620	2700	1.65	37300	318

Center of Gravity

Correct center of gravity is directly related to the success of the flight, please refer to the following CG diagram to adjust your plane's center of gravity.

- You can move the battery forward or backward to adjust the center of gravity.
- If you can not adjust the CG through move the battery, you can also use some other suitable material weight to counterweight, to make sure that CG is in the correct position.

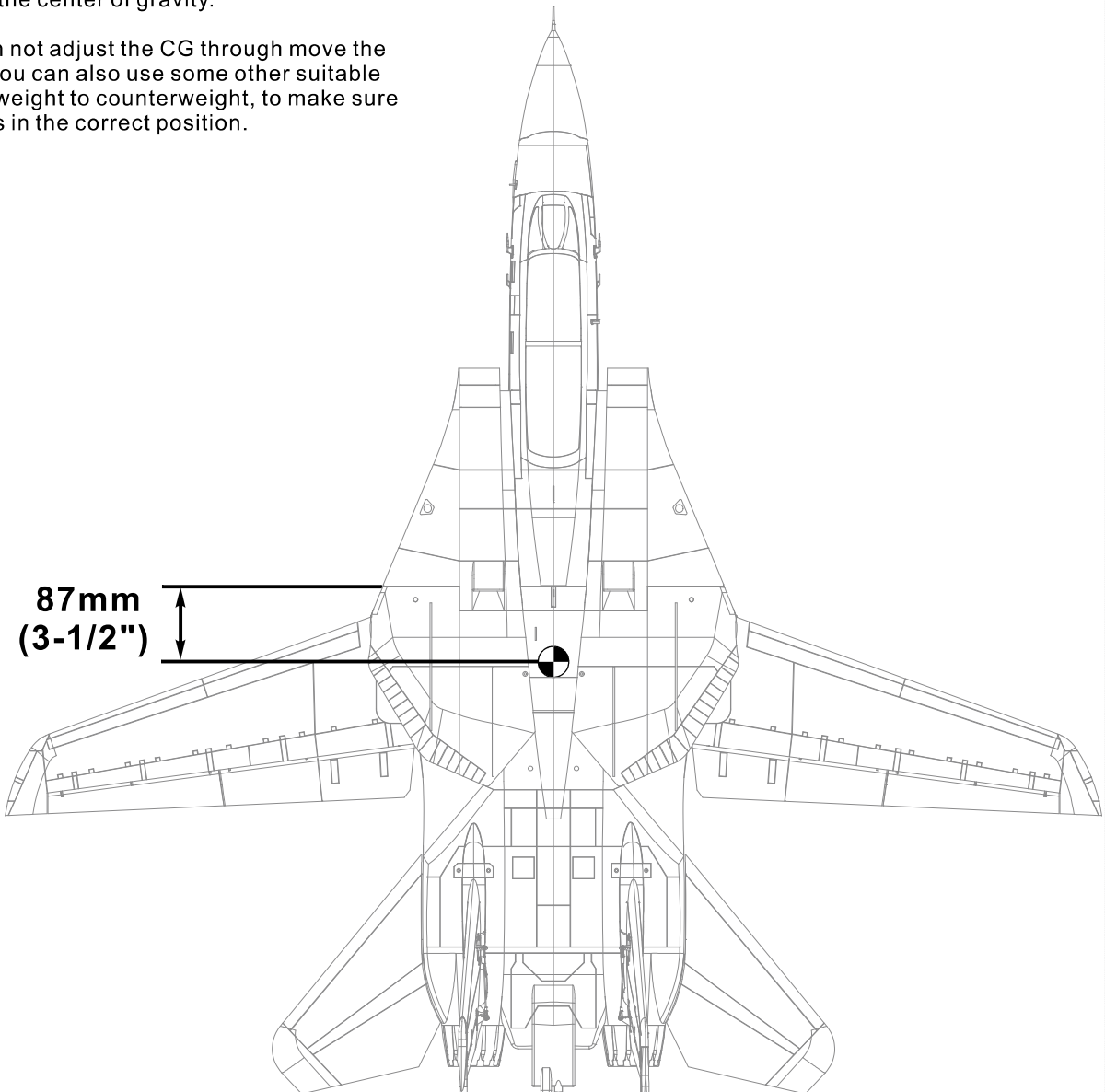

Control direction test

EN

After installed the plane, before flying, we need a fully charged battery and connect to the ESC, then use radio to test and check that every control surface work properly.

Aileron

Stick Left



Stick Right



Elevator

Up Elevator



Down Elevator



Rudder

Stick Left



Stick Right



Optional Flaps

Flaps down



Sweep wing

Sweep wing
switch off

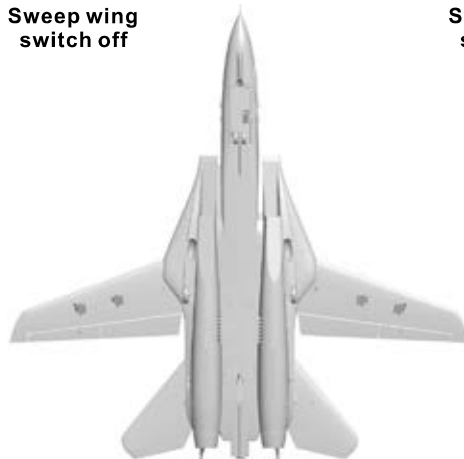

Sweep wing
switch on

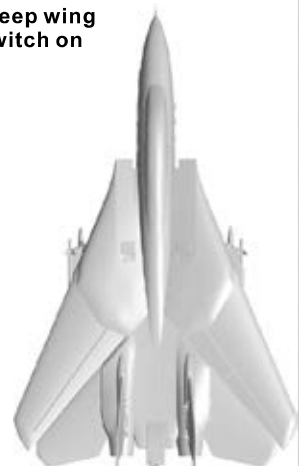

Dual Rates

EN

F-14, in forward wing condition and in swept wing condition, the control sensitivity will change. We advise you set up the rate according to the following parameters. According to sweep change, to switch different rate, make your operation more easier.

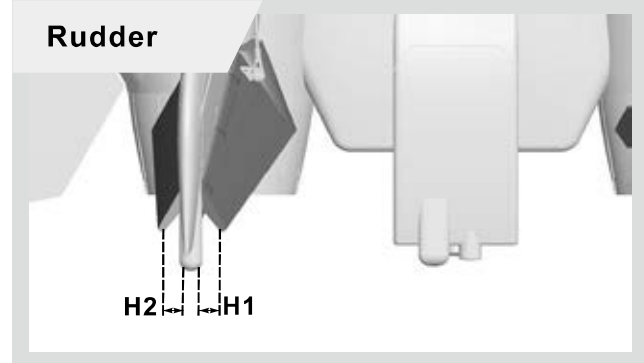
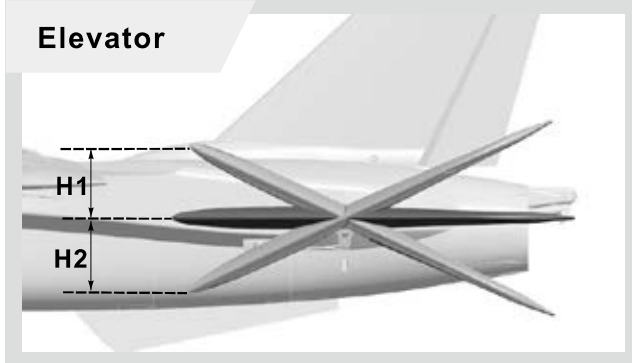
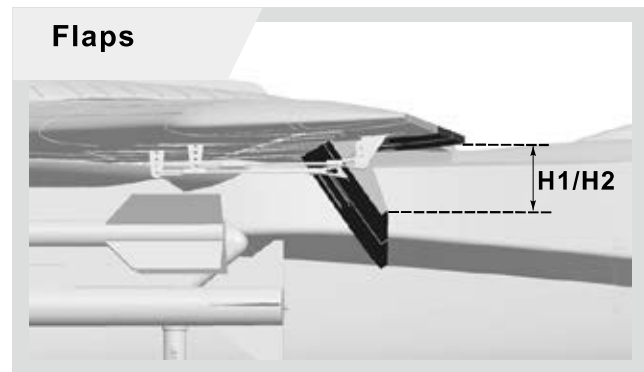
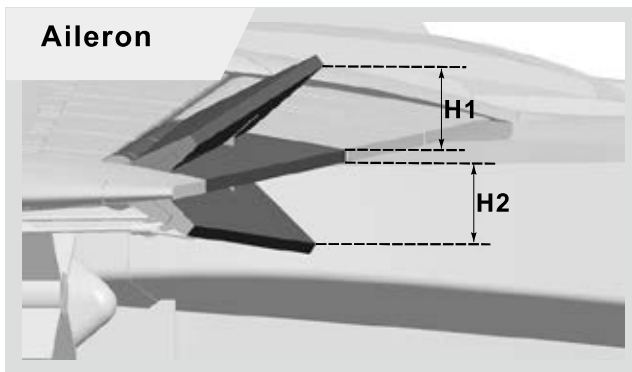

	High Rate	Low Rate
Aileron	H1/H2 14mm D/R Rate : 100%	H1/H2 8mm D/R Rate : 65%
Flaps	H1/H2 40mm	H1/H2 30mm
Elevator	H1/H2 34mm D/R Rate : 100%	H1/H2 24mm D/R Rate : 65%
Rudder	H1/H2 30mm D/R Rate : 100%	H1/H2 20mm D/R Rate : 65%

Elevator install angle correction

Caution: Neutral point of full elevator should be correct, it affects your flight directly. Please refer to the left photo to correct your full elevator install angle!

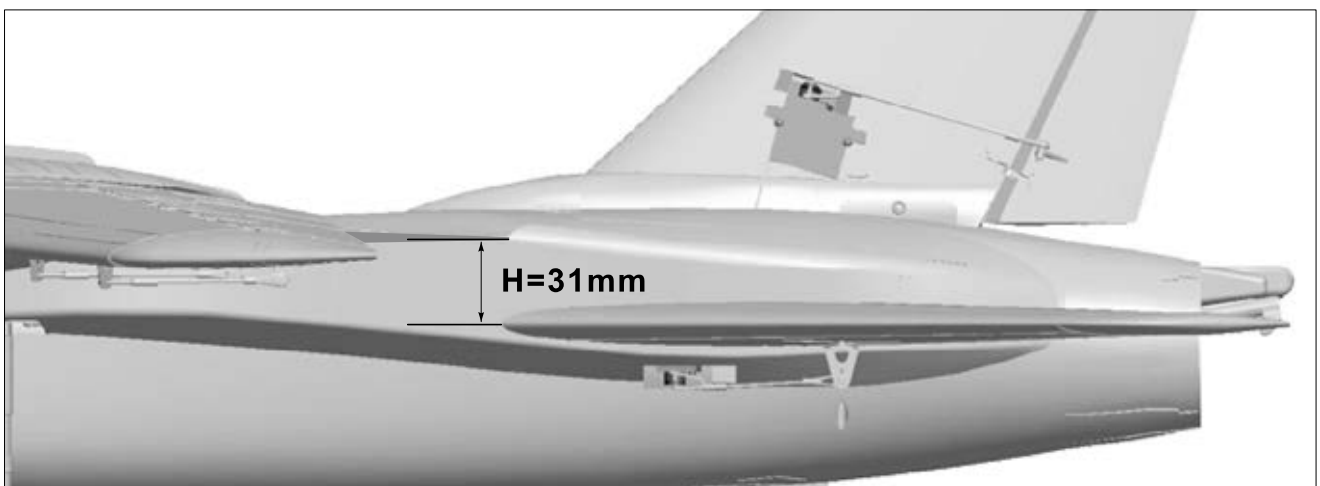



Dongguan Freewing Electronic Technology Ltd
HK Freewing Model International Limited

Add.:FeiYi Building,face to Labor Bureau, Fumin Middle Road, Dalang Town,
Dongguan City , Guangdong Province, China

Web: <http://www.sz-freewing.com>

Email:freewing@sz-freewing.com

Tel: 86-769-82669669 Fax:86-769-82033233

东莞市飞翼电子科技有限公司
香港飞翼模型国际有限公司

地址: 广东省东莞市大朗镇富民中路402-408号飞翼楼四楼

Web: <http://www.sz-freewing.com>

Email:freewing@sz-freewing.com

Tel: 86-769-82669669 Fax:86-769-82033233

