

Item No.:FJ2061  
Version No.:FJ2061-V01

**FreeWing** MIDEL®  
www.sz-freewing.com

# MIRAGE2000 USER MANUAL



80MM EDF JET

WIDSPAN: 790MM (31.1 IN.)

LENGTH: 1250MM (49.21 IN.)

EN 1 ~ 13

中 14 ~ 26



CE   
MADE IN CHINA

80mm EDF Mirage2000 C! The famous tailless delta wing fighter, has a great "instant circling rate"; Mirage series aircraft, is the pride of the French aerospace industry, this aircraft has created a new era ----- Mirage era ! Mirage fighter, produced a total of more than 600 aircraft, including France, total have 9 countries use them.

Now Freewing produced this classic fighter model ,80mm EDF Mirage2000 C model plane, many details of real plane, it showd perfectly. Excellent painting and decals make it perfection. This product use 12-blade 80mm metal EDF, powerful power output, let it has excellent vertical climb and maneuverability. The delta jet 's high alpha maneuver featured, in here the performance showed thoroughly, we can slow down gently to land the plane.

Every part of 80mm EDF Mirage 2000 can assemble/disassemble freely, very convenience to carry. Excellent landing gear design, it make sure that we can take-off/land in grass without damage landing gear

**⚠ NOTE:** This is not a toy. Not for children under 14 years. Young people under the age of 14 should only be permitted to operate this model under the instruction and supervision of an adult. Please keep these instructions for further reference after completing model assembly.

## Note:

- 1.This is not a toy! Operator should have a certain experience, beginners should operate under the guidance of professional players.
- 2.Before install, please read through the instructions carefully and operate strictly under instructions.
- 3.Cause of wrong operation, Freewing and its vendors will not be held responsible for any losses.
- 4.Model planes' players must be on the age of 14 years old.
- 5.This plane used the EPO material with surface spray paint, don't use chemical to clean, otherwise it will damage.
- 6.You should be careful to avoid flying in areas such as public places, high-voltage-intensive areas, near the highway, near the airport or any other place where laws and regulation clearly prohibit.
- 7.You cannot fly in bad weather conditions such as thunderstorms, snows....
- 8.Model plane's battery, don't allowed to put in everywhere. Storage must ensure that there is no inflammable and explosive materials in the round of 2M range.
- 9.Damaged or scrap battery should be properly recycled, it can't discard to avoid spontaneous combustion and fire.
- 10.In flying field, the waste after flying should be properly handled, it can't be abandoned or burned.
- 11.In any case, you must ensure that the throttle is in the low position and transmitter switch on, then it can connect the lipo-battery in aircraft.
- 12.Do not try to take planes by hand when flying or slow landing process. You must wait for landing stop, then carry it.

Product Basic Information .....	2
Package List .....	2
Installing Plane .....	3
Servo Introduction .....	8
Battery .....	8
Power System .....	9
Center of Gravity .....	10
Control Surface Direction and Set Up .....	11
Dual Rates .....	12
Troubleshooting Guide .....	13

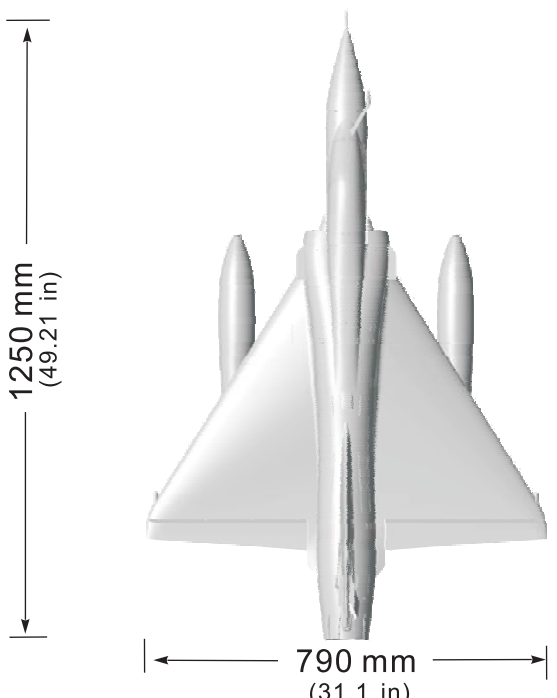
 <p>1250 mm (49.21 in)</p> <p>790 mm (31.1 in)</p> <p><b>Note:</b> The parameters in here are derived from test result using our accessories. If use other accessories, the test result will be different. Any problem since of using other accessories, we are not able to provide technical support.</p>	<p><b>4S Standard Version</b></p> <ul style="list-style-type: none"> <li>● Motor 3525-2870KV</li> <li>● ESC 80A (5A BEC)</li> <li>● Servo 9g (4pcs)</li> <li>● Battery 4S 14.8V 4000mAh 35C</li> <li>● Ducted fans 6-Bladed 80mm EDF</li> <li>● Take-off weight 1900g (67 oz.)</li> <li>● Thrust 1900g (67 oz.)</li> </ul>
	<p><b>6S Upgrade Version</b></p> <ul style="list-style-type: none"> <li>● Motor 3530-1750KV</li> <li>● ESC 80A (5A BEC)</li> <li>● Servo 9g Metal Gear Servo (4pcs)</li> <li>● Battery 6S 22.2V 4000mAh 35C</li> <li>● Ducted fans 12-Bladed 80mm EDF</li> <li>● Take-off weight 2200g (77.6 oz.)</li> <li>● Thrust 2600g (91.8 oz.)</li> </ul>

## Package list



Different equipment include different spareparts. Please refer to the following contents to check your sparepart list.

### PNP equipment list

1. Fuselage set (installed, include the electric parts and connection lines)
2. Main wing set (installed, include the electric parts and connection lines)
3. Rudder (installed, include the electric parts and connection lines)
4. Drop tank & pylons, nose cone, tail vector.
5. The tubing, plastic part.
6. Rear landing gear, carbon tube
7. Screw
8. Glue

### KIT equipment list

1. Fuselage set
2. Main wing set
3. Rudder
4. Drop tank & pylons, nose cone, tail vector.
5. The tubing, plastic part.
6. Rear landing gear, carbon tube
7. Screw
8. Glue

1. Use glue to attach front, rear fuselage.
2. Use glue to attach the left, right main wing on the fuselage.

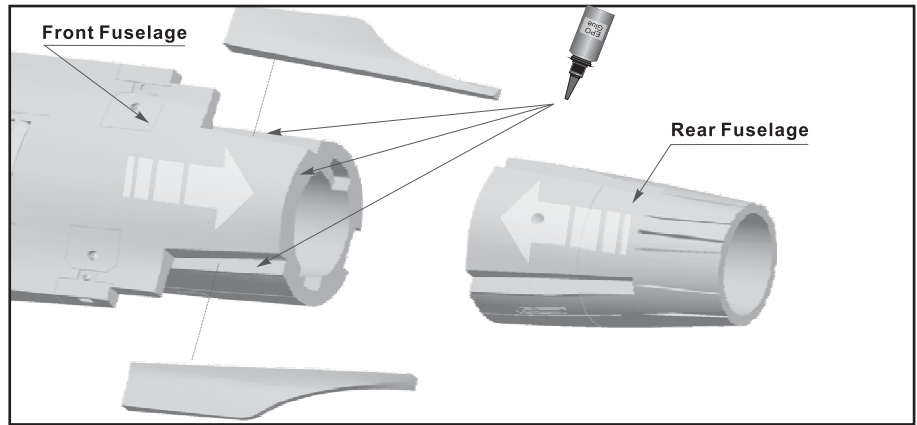

## Installing Rudder

### Installing Rudder Servo

- A - Screw (PWA1.7\*5mm)
- B - 9g servo cover
- C - 9g servo box
- D - Control surface horn
- E - Rudder pushrod
- F - Trough

1. Center the servo arm through servo tester or radio.
2. Apply the glue to attach the "9g servo box (C)" and "control surface horn (D)" on the rudder.
3. Install the servo in the "9g servo box (C)", and press the servo cable in the "trough (F)", then cover the "9g servo cover (B)" and fix it by 2 pcs "screws (A)".
4. Use rudder pushrod to connect the servo arm and "control surface horn (D)".

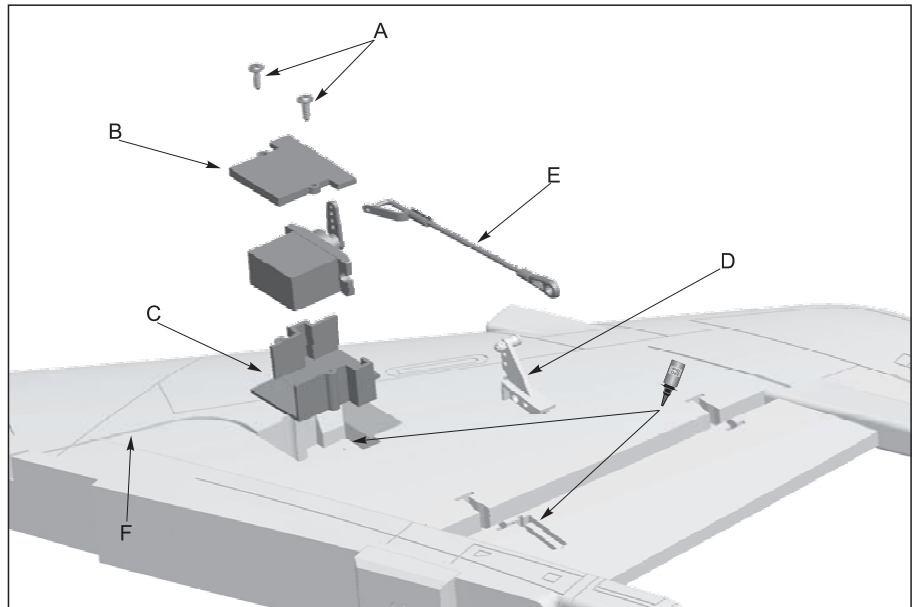

Through adjust the length of pushrod to center the elevator.

### Installing Rudder

1. Connect the rudder servo cable and extension line in fuselage.
2. Insert the rudder into fuselage and use screw to fix the rudder.

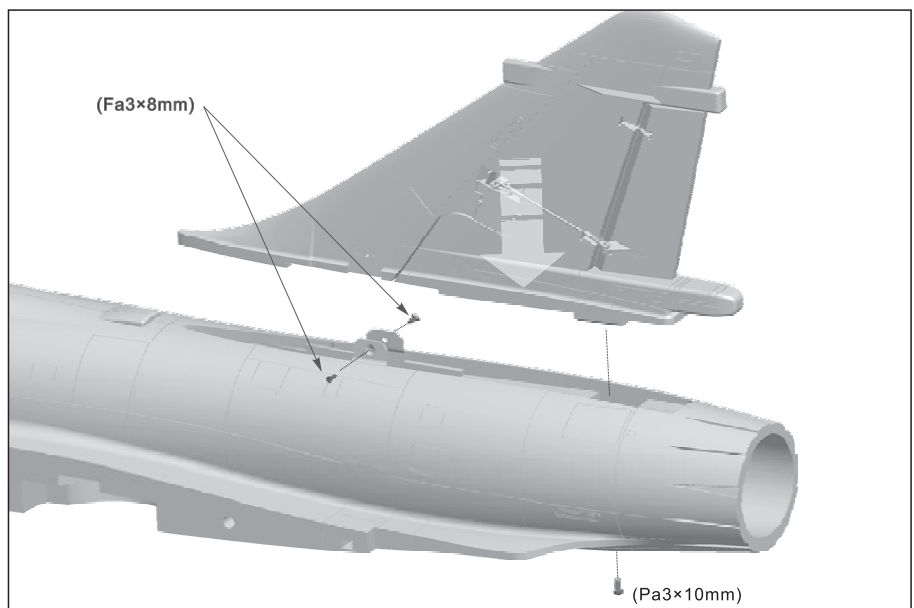

## Installing the main wing

1. Remove the carbon tube from package box, and insert it into the fuselage as the right photo shown.
2. Connect the servo cable of left, right main wing to the extension line in fuselage.
3. Insert the left/right main wing into the fuselage.
4. Use screw to fix the main wing plastic dowel pin to finish its installation.

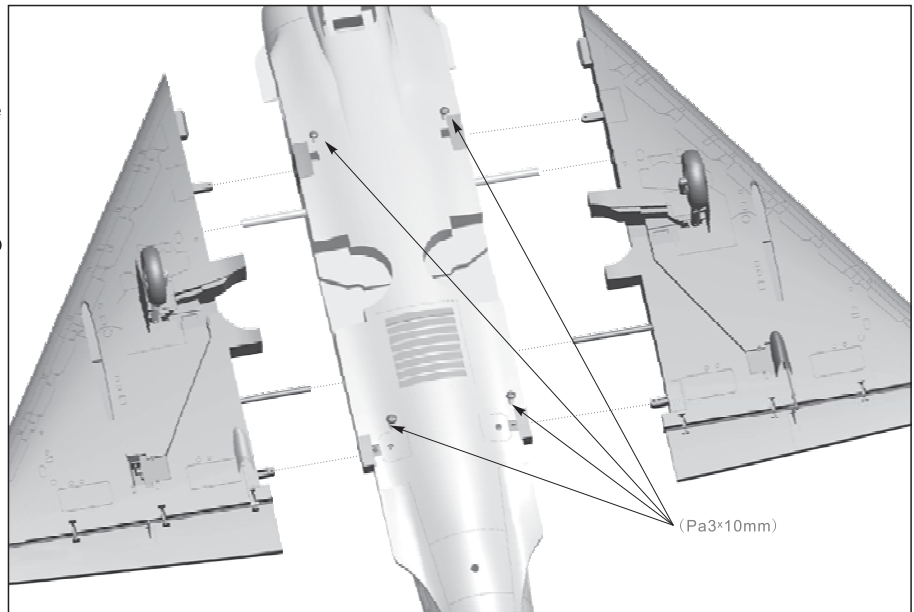

## Installing Main Wing Servo

- A - Screw (PWA1.7x5mm)
- B - 9g servo cover
- C - 9g servo box
- D - Control surface horn
- E - Pushrod
- F - Trough

1. As the right photo shown, use glue to attach the "9g servo box (C)" and "control surface horn (D)" on the main wing.
2. Put the 9g servo in the "9g servo box (C)", and press the servo cable into the "main wing trough (F)".
3. Cover the "servo cover (B)" on the "9g servo box (C)", and fix it by 2 pcs "screws (A)".
4. Use "pushrod (E)" to connect the servo arm and control surface horn.
5. Adjust to center the aileron.

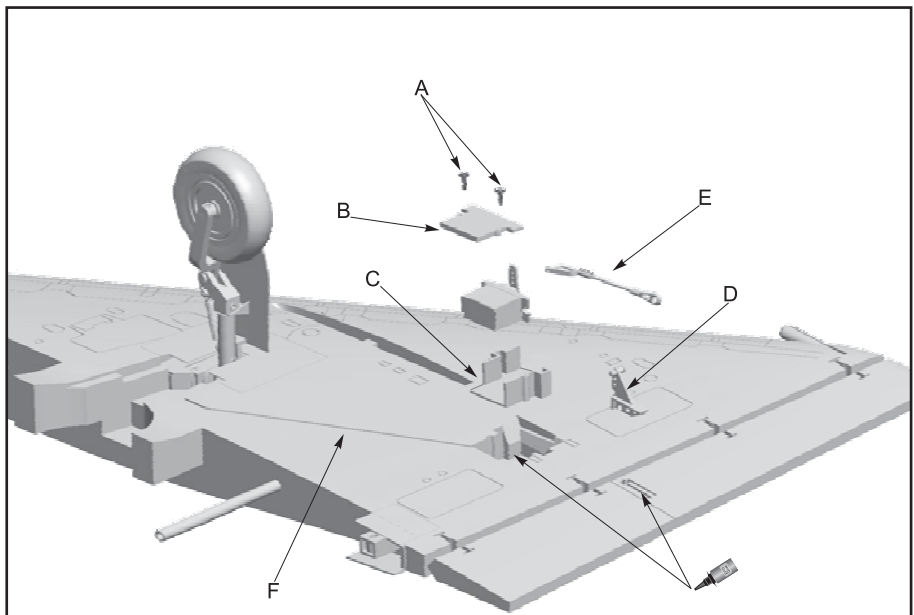

**Note:** we have installed all the servo box in aircraft, when players disassemble the servo, it will not damage the foam surface. If need to replace servo, please purchase Freewing servo, or refer to the following drawing, choose the correct size servo.

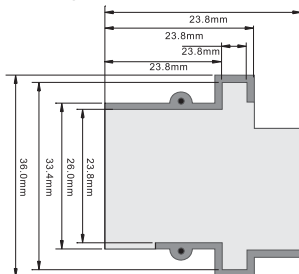

### Rudder pushrod size

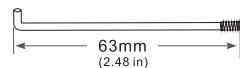

Pushrod diameter : Ø 1.5mm

### Aileron pushrod size



Pushrod diameter : Ø 1.5mm

### Rudder pushrod mounting hole



### Aileron pushrod mounting hole



1. Since of magnet absorption, we only need to put the nose cone on the front of fuselage.

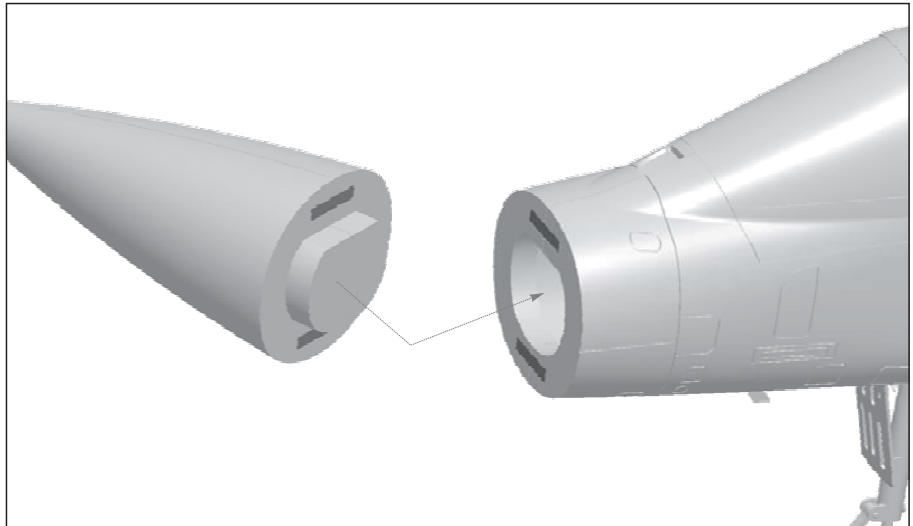

2. As the right photo shown, use glue to attach the tubing on the front of canopy.

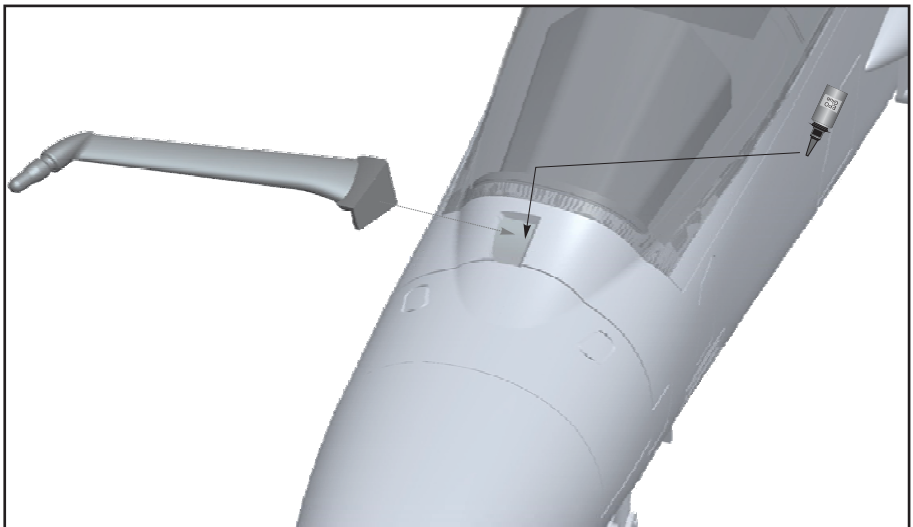

### Installing drop tank and pylons

1. Use glue to attach the drop tank and pylons.
2. Pylons attached magnets, absorb it on the below surface of main wing.

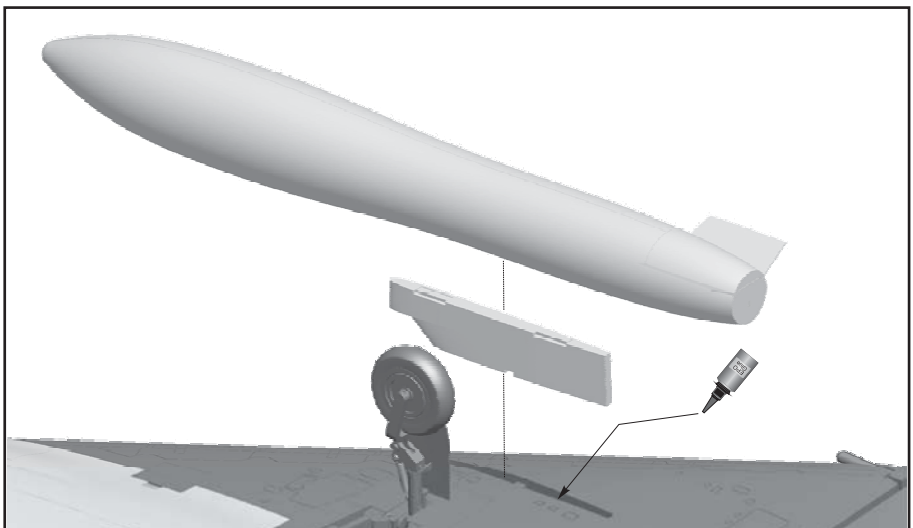

## Nose landing gear list:

- A- Retractable controller
- B- E-buckle (Ø2.0mm)
- C- Rotating arm
- D- Nose landing gear metal wire
- E- Screw (PT2.6\*6mm)
- F- Nose landing gear main strut
- G- U-shape damping arm
- H- Spring
- I- Damping active lever
- J- Nose landing gear steering pushrod
- K- Nose landing gear steering control ring
- L- L-shape arm
- M- Jimi screw (M4\*3mm)
- N- Screw (PM2\*4mm)
- O- Screw (PM2\*3mm)
- P- Damping slant supporting rod
- Q- 8-shape damping shaft
- R- Jimi screw (M3\*3mm)
- S- Nose wheel shaft
- T- Wheel (Ø35\*10mm)
- U- E-buckle (Ø1.5mm)
- V- Pin
- W- Nose landing gear set
- X- Screw (PA2.6\*10mm)
- Y- Nose landing gear mount

1. At first, disassemble the "retractable controller (A)", and remove the "rotating arm (C)".
2. Insert the "nose landing gear metal wire (D)" into the "rotating arm (C)" and use "E-buckle (B)" to fix.
3. Put the "nose landing gear steering control ring (K)" into "nose landing gear steering pushrod (J)" and screw it to the "L-shape arm (L)".
4. Put the "L-shape arm (L)" and "nose landing gear main strut (F)" on the "nose landing gear metal wire (D)", and use 2pcs "Jimi screws (M)" and "screw (E)" to fix.
5. Put the "U-shape damping arm (G)" on the "nose landing gear main strut (F)" and fix it by "screw (O)".
6. Insert the "Spring (H)", damping active lever (I)" into the "nose landing gear main strut (F)", and press the "damping active lever (I)" down, lock the screw to the hole of "nose landing gear main strut", and fix the "damping active lever (I)" to prevent its fall off.
7. Use "pin (V)" and E-buckle (U)" to connect the "damping slant supporting rod (P)", 8-shape damping shaft (Q), U-shape damping arm (G)" and fix them.
8. Put the "wheel (T1)" in the "nose wheel shaft (S)", then insert the "nose wheel shaft (S)" into the "damping slant supporting rod (P)", use "jimi screws (R)" to fix. Then insert the other "nose wheel (T2)" in the "nose wheel shaft (S)", use "E-buckle (B2)" to fix.
9. Assemble the retractable controller again.
10. Install the installed "nose landing gear set (W)" on the "nose landing gear mount (Y)", use 4pcs "screws (X)" to fix.

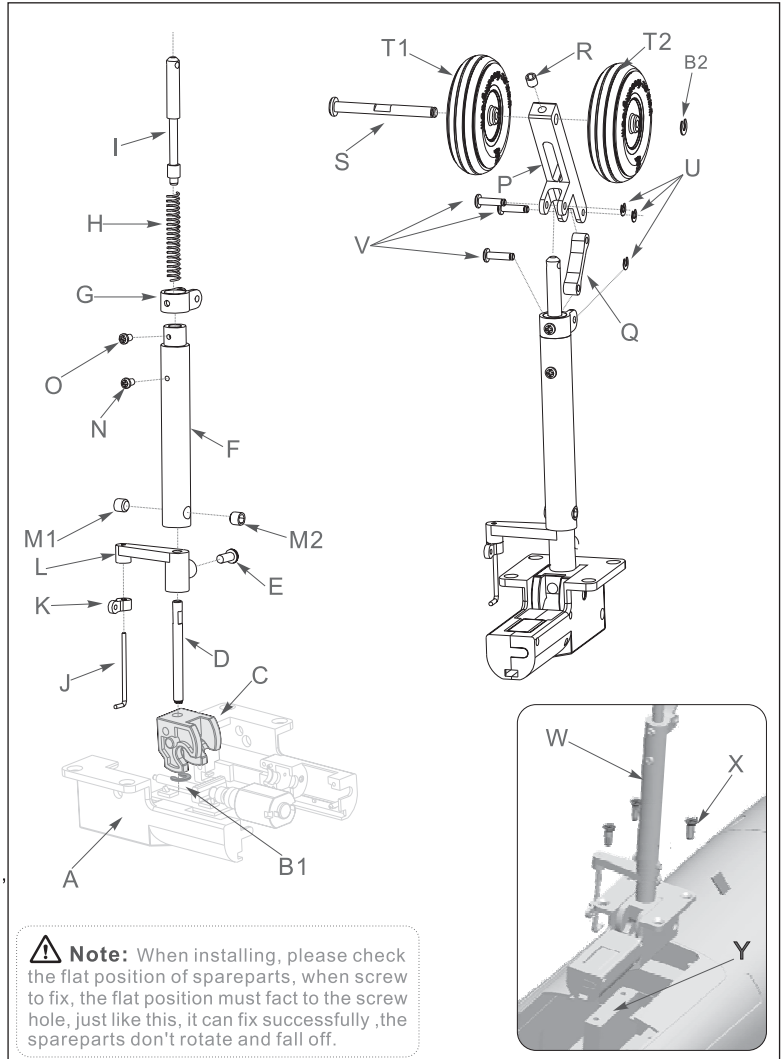

## Installing cabin door of nose landing gear

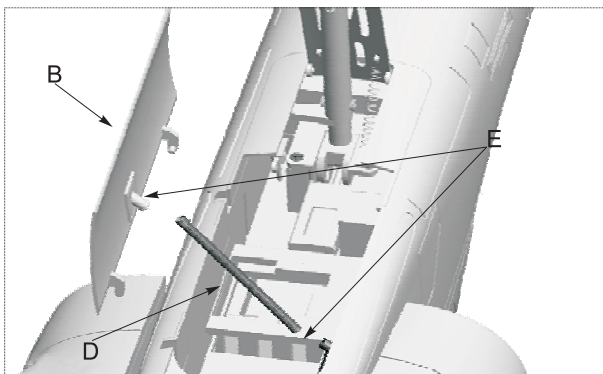

- A- Nose gear cabin door (Front)
- B- Nose gear cabin door (Rear)
- C- Spring 1
- D- Spring 2
- E- Spring fixed part E

1. Install the rotating buckle of "Nose gear cabin door –front (A)" to the rotating shaft in the front of landing gear fixed mount.
2. Put one side of "Spring 1 (C)" to buckle the "Nose gear cabin door –front (A)", use screw to fix the other side on the nose gear controller.
3. Install the rotating buckle of "Nose gear cabin door –rear (B)" to the rotating shaft in the side of landing gear fixed mount.
4. Put one side of "Spring 2 (D)" to buckle the "Nose gear cabin door –rear (B)", put the other side on the "Spring fixed part (E)".

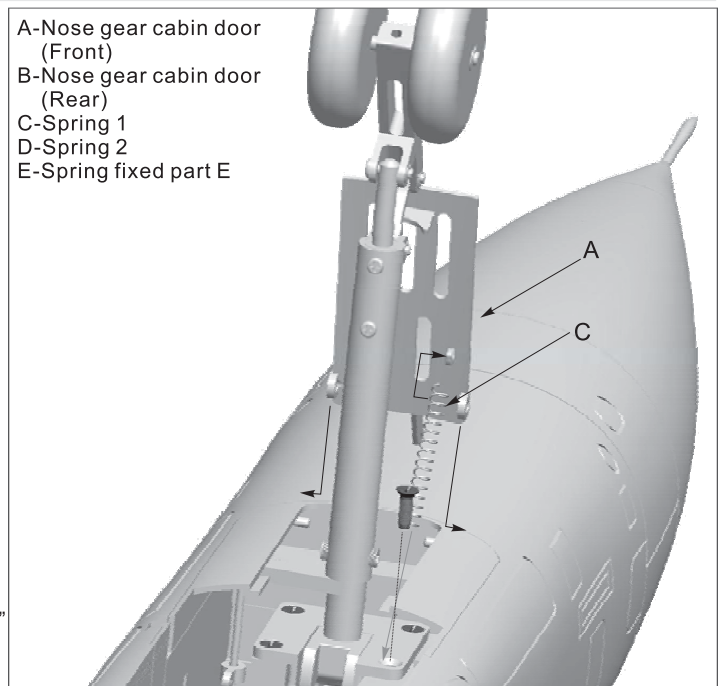

**Accessories list:**

- A-Servo fixed frame
- B-Servo (9g)
- C-Wood piece
- D-Screw (PWA2×8mm)
- E-Screw (PWA1.7×5mm)
- F-Pushrod fixed bolt
- G-Steering pushrod
- H-Nose gear steering control ring

- 1.Center the arm of “servo (B)”.
- 2.Use “screw (D)” to fix the 9g “servo (B)” on the “servo fixed frame (A)”.
- 3.Use “screw (E)” to fix the installed “servo fixed frame (A)” on the “wood piece (C)”.
- 4.Use “steering pushrod (G)” to connect the “pushrod fixed bolt (F)” and “nose gear steering control ring (H)”.

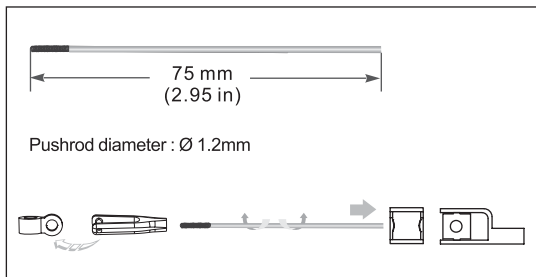
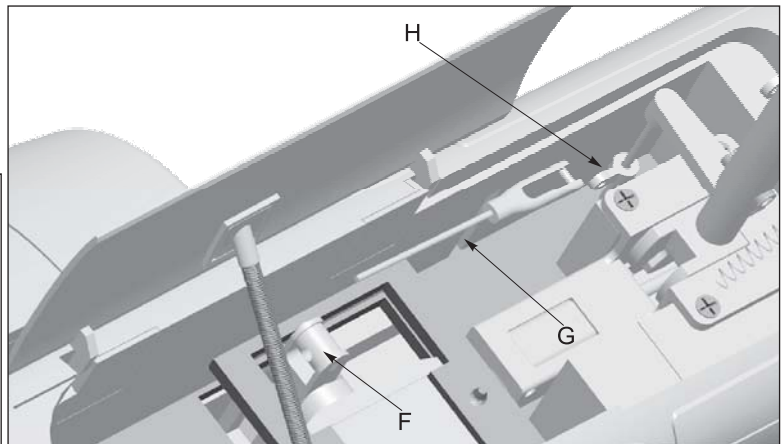
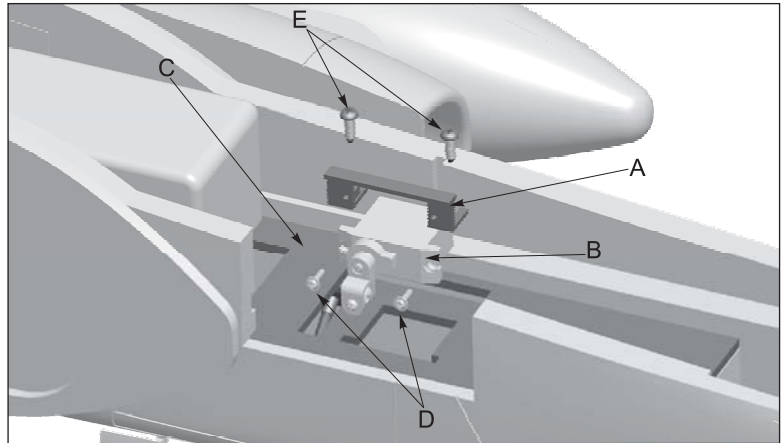

# Installing rear landing gear

**Accessories list**

- A-Retractable controller
- B-Rear landing gear metal wire
- C-Rear landing gear main supporting rod
- D-Rear landing gear slant supporting rod
- E-Rear landing gear shock absorber arm
- F-Spring
- G-Wheel shaft
- H-Wheel
- I - Pin
- J-E-buckle (Ø1.5mm)
- K-Jimi screw (M3×3mm)
- L-Jimi screw (M4×3mm)
- M-Screw (Pm3×4mm)
- N-Screw (PA2.6×10mm)
- O-Screw (Pm4×3mm)
- P-Rear landing gear cabin door
- Q-Landing gear
- R-Landing gear decorated cover

- 1.Insert the “Rear landing gear metal wire (B)” to the “retractable controller (A)”. and use 2pcs “Jimi screw (K)” to fix.
- 2.Firstly, put the “rear landing gear main supporting rod (C)” to the “Rear landing gear metal wire (B)”, and fix it with 2pcs “Jimi screw (L)”. Next, put the “Rear landing gear slant supporting rod (D)” to the end of “rear landing gear main supporting rod (C)” and use 2pcs “jimi screws (L)” to fix.
- 3.Use “Pin (I)” “E-buckle (J)” to connect the “Rear landing gear slant supporting rod (D)” and “Rear landing gear shock absorber arm (E)”. Then, Use 2pcs “screw (M)” to fix separately the two side of “Spring (F)” on the “Rear landing gear slant supporting rod (D)” and “rear landing gear main supporting rod (C)”.
- 4.The “ wheel shaft (G)” go across the “ Wheel (H)”, insert into the hole in the end of “Rear landing gear shock absorber arm (E)”, and use “Jimi screw (K)” to fix the “ wheel shaft (G)”.
- 5.Use 4pcs “screw (N)” to fix the installed “ landing gear(Q)” on the main wing, and press the wires in the trough.
- 6.After installed the landing gear, use 1pcs “screw (O)” to fix the “Rear landing gear cabin door (P)” on the “Rear landing gear slant supporting rod (D)”.
- 7.Use glue to attach the “landing gear decorated cover (R)” on the main wing as the photo shown.

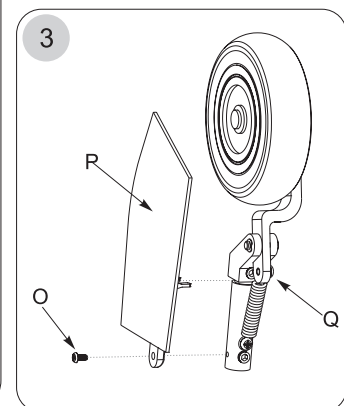
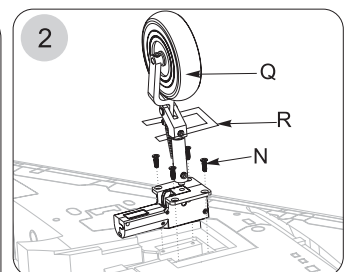
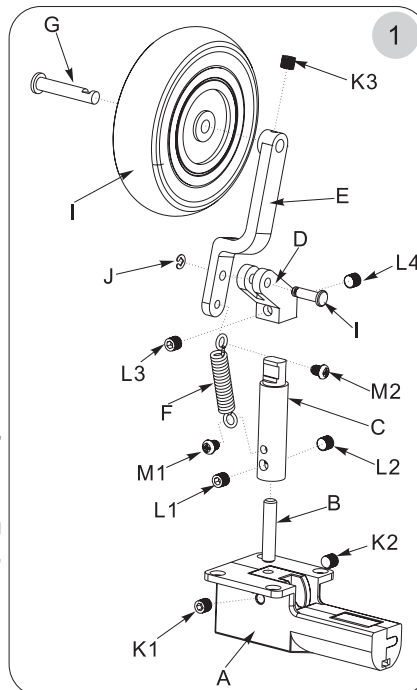



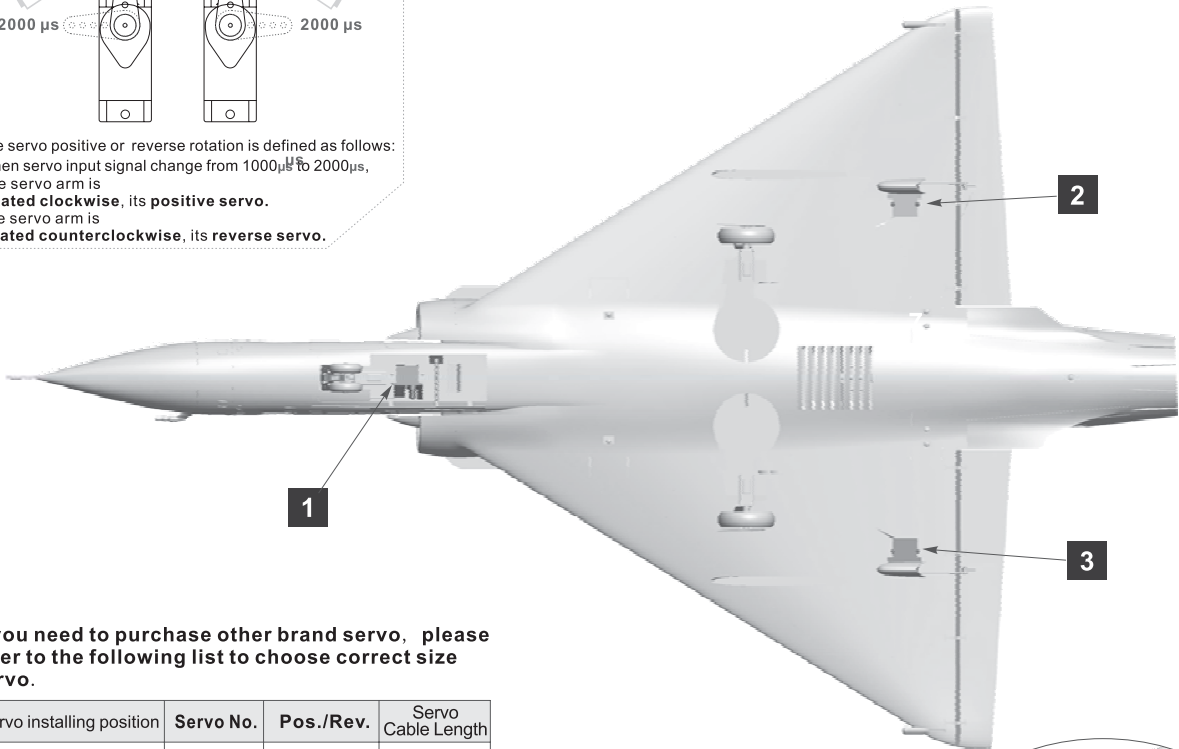
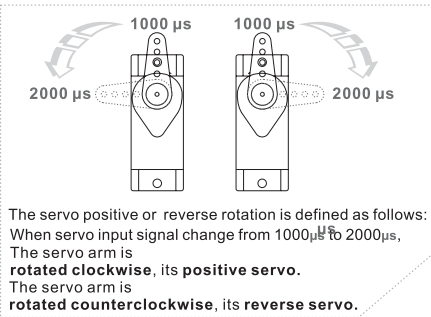

If you need to purchase other brand servo, please refer to the following list to choose correct size servo.

Servo installing position	Servo No.	Pos./Rev.	Servo Cable Length
Nose gear steering servo	1	Reverse	250mm
Aileron servo (Left)	2	Positive	500mm
Aileron servo (Right)	3	Positive	500mm
Rudder servo	4	Positive	250mm

### Servo connection instruction

1. Use Y wire to connect the servos (No. 1, No. 4), then insert to rudder channel in receiver.
2. Insert No. 2 servo and NO. 3 servo into the aileron channel and elevator channel in receiver.
3. Set up a "delta mix" in transmitter, and achieve our movement.



### Install on battery

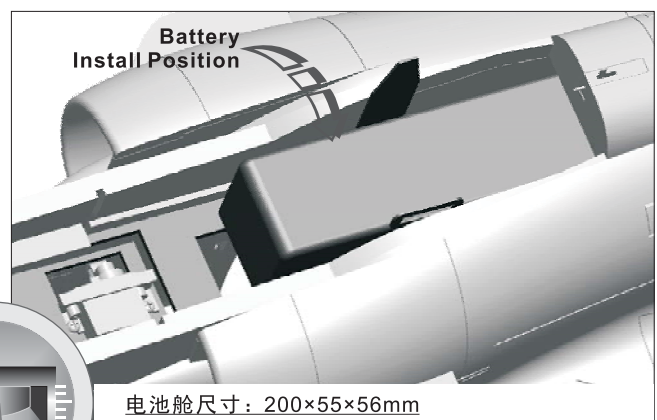
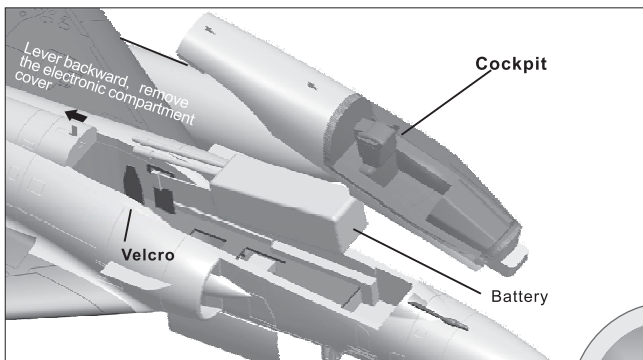

Lever backward, remove the electronic compartment cover, then bundled battery with Velcro.

Before connect battery and receiver, please switch on the transmitter and check that the throttle is in the low position.

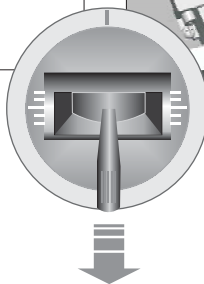

电池舱尺寸: 200×55×56mm

Our standard battery is:

**4S 14.8V 4000mAh 35C**

**OR 6S 22.2V 4000mAh 35C**

The battery capacity and discharge rate we advise is in the following:

4S 14.8V 3700mAh ~ 4S 14.8V 4500mAh

6S 22.2V 3700mAh ~ 6S 22.2V 4500mAh

**Discharge rate of C ≥ 30C**

Different weight battery may affect its CG, please the correct range of CG indication.

1. Install the "motor (D)" in the "ducted fan housing (C)".
2. Fix the motor by 4pcs "cup head screws (B)".
3. Put the "rotor (E)" in the motor shaft.  
(During this process, please note the hardware platform of rotor should be alignment with the motor shaft platform)
4. Use "spinner (F)" to cover the rotor, and fix the "spinner (F)" by "cup-head-screw (G)".
5. Install the "tail air-deflector (A)" on the "bottom of ducted fan housing (C)", and use 2pcs "jimi screws (H)" to fix.
6. Connect the motor and ESC.
7. Put the "installed EDF (I)" in the fuselage.
8. Use 4pcs "screws (K)" to fix the "EDF (I)" on the fixing wood piece.
9. At last use 2 pcs "screws (L)" to fix well the "EDF cover (M)".

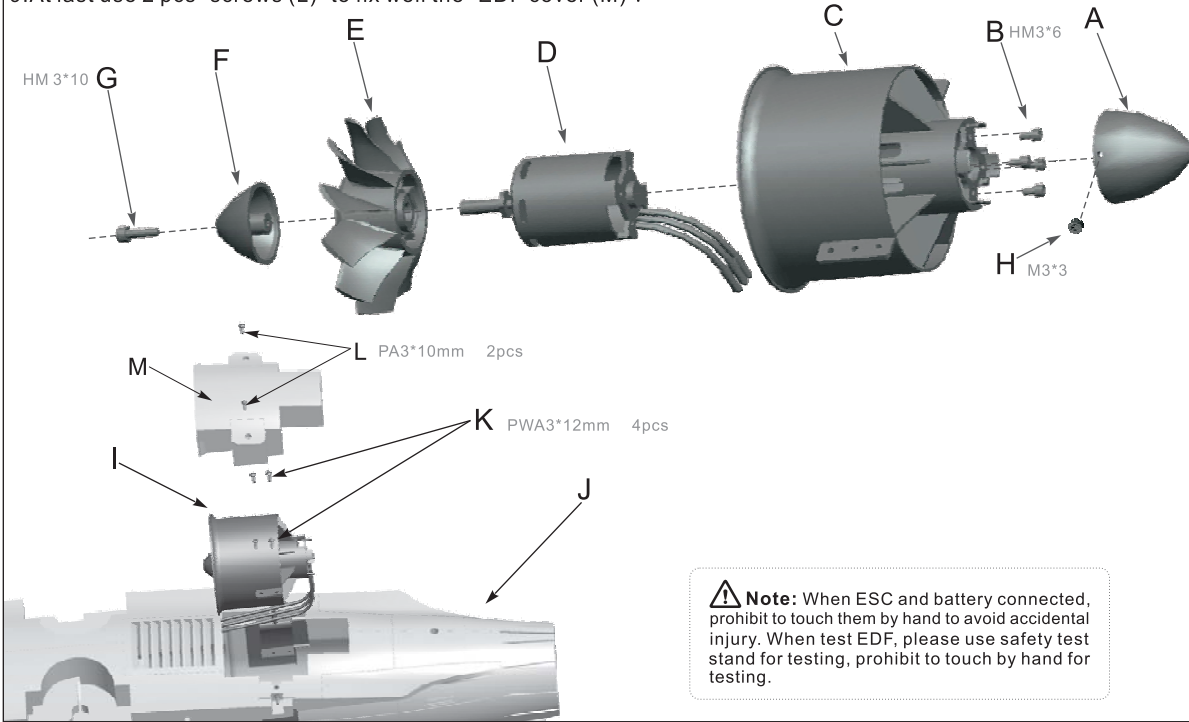

## Motor Parameters

<p><b>MOJ35251</b> 3525-2870KV For 4S Battery Standard Version</p>			
<p><b>MOJ35301</b> 3530-1750KV For 6S Battery Upgrade Version</p>			

Item No.	KV Value	Volute (V)	Current (A)	Thrust (g)	Motor Resistance	Weight (g)	No Load Current	Propeller	ESC
MOJ35251	2870RPM/V	14.8	63	1900	0.0087Ω	125	4.8A/15V	6-Bladed 80mm Ducted Fan	≥ 80A
MOJ35301	1750RPM/V	22.2	72	2600	0.0146Ω	150	4.6A/23V	12-Bladed 80mm Ducted Fan	≥ 80A

Correct center of gravity is directly related to the success of the flight, please refer to the following CG diagram to adjust your plane's center of gravity.

- You can move the battery forward or backward to adjust the center of gravity.
- If you can not adjust the CG through move the battery, you can also use some other suitable material weight to counterweight, to make sure that CG is in the correct position.

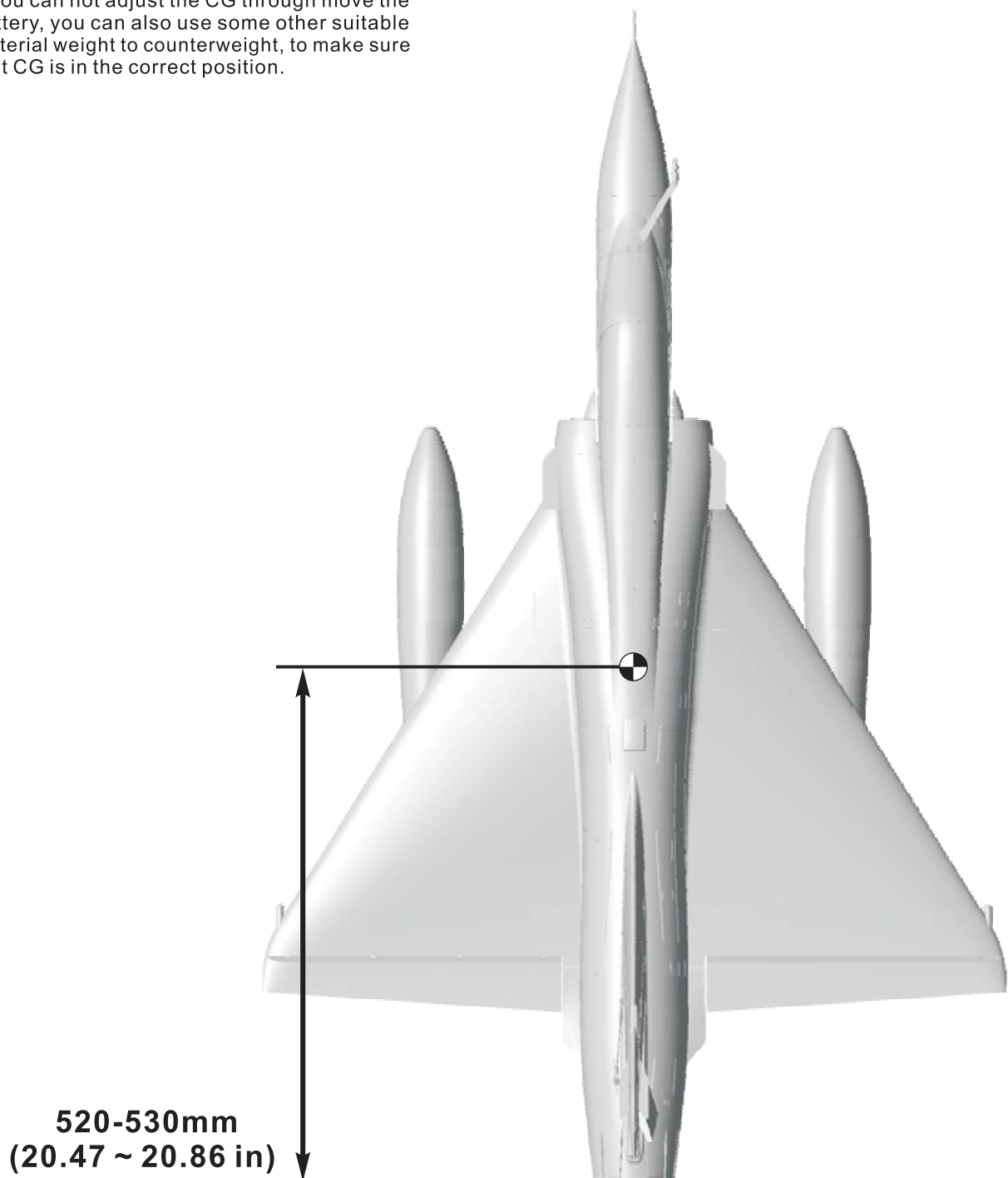

After installed the plane, before flying, we need a fully charged battery and connect to the ESC, then use radio to test and check that every control surface work properly.

**Aileron**

Stick Left

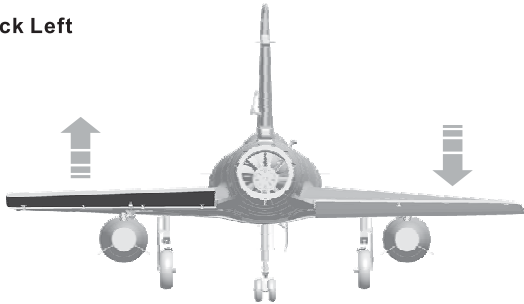

Stick Right

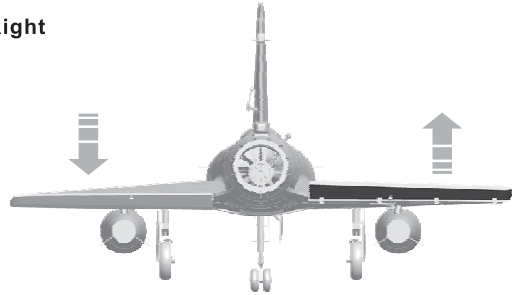

**Elevator**

Up Elevator

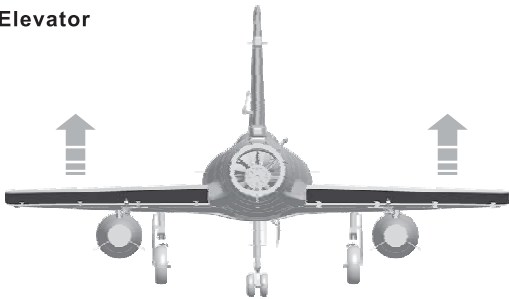

Down Elevator

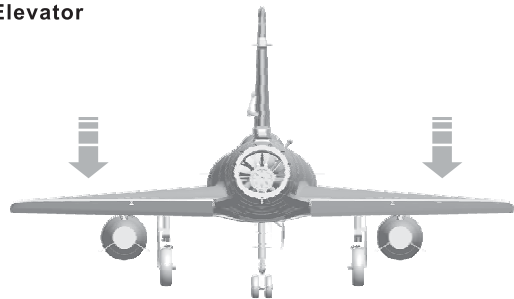

**Rudder**

Stick Left

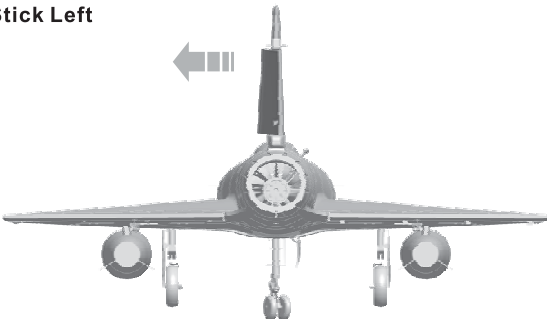

Stick Right

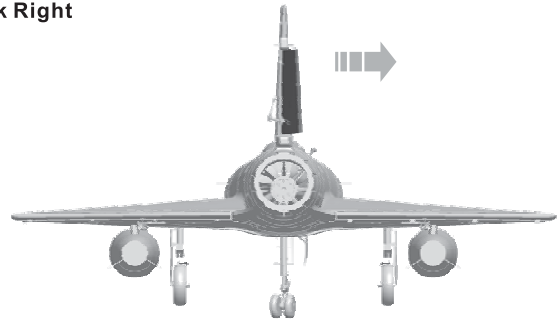

According to our testing experience, according to the following parameters to set the aileron/elevator rate, it will be useful for flight. In low rate, its good for flight control and its suitable for the initial flight or less skilled players. According to your own circumstance, choose one rate in flight.

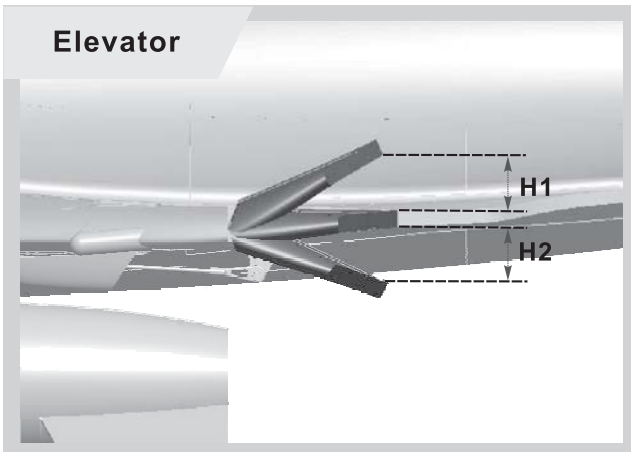
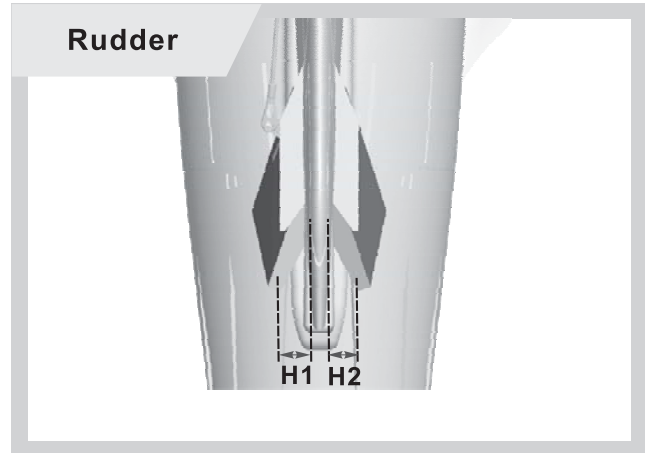
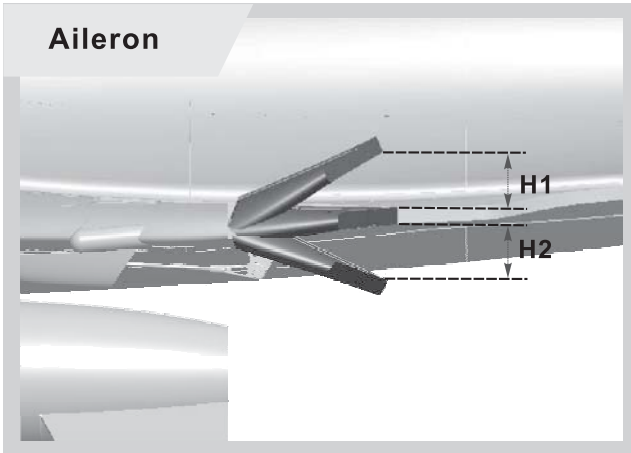

	Aileron	Rudder	Elevator
<b>Low Rate</b>	H1/H2 11mm/11mm	H1/H2 18mm/18mm	H1/H2 10mm/10mm
<b>High Rate</b>	H1/H2 16mm/16mm	H1/H2 28mm/28mm	H1/H2 16mm/16mm

Motor does not turn on	A) Li-Po battery depleted	A) Recharge Li-Po battery
	B) Transmitter batteries depleted	B) Replace or recharge batteries
	C) Transmitter not turned on	C) Turn on transmitter
	D) Li-Po battery not plugged in	D) Plug in Li-Po battery
	E) Motor not armed	E) Arm motor
	F) A crash has damaged an internal component	F) Replace
	G) ESC or other damaged	G) Check ESC or contact local distributor
Cub is difficult to control	A) You are flying in too much wind	A) Fly when there is no wind
	B) Li-Po battery depleted	B) Recharge Li-Po battery
	C) Transmitter batteries depleted	C) Replace or recharge batteries
	D) Transmitter antenna not extended completely	D) Extend transmitter antenna completely
	E) Surface control rate is too high	E) Use low rate to fly
The nose always move down when fly, always need to up elevator	A) CG is forward	A) Adjust CG backward refer to instruction
Cub constantly climbs or descends, or turns right or left without control input	A) The aircraft is out of trim adjustment	A) Adjust the transmitter trim tabs
	B) You are flying in too much wind	B) Fly when there is no wind
Elevator is too flexible, up and down is not stable	A) CG is backward	A) Adjust CG forward refer to instruction
Plane will be slant when taxi on the runway	A) Nose gear is not center.	A) Center nose gear
	B) Rudder is not center.	B) Center rudder
Take off is difficult	A) Thrust is not on the high position	A) Thrust is on the high position
	B) Taxi distance is not enough	B) Long taxi distance
	C) Elevator rate is not enough high	C) Use high rate of elevator
Cub will not climb	A) Li-Po battery is depleted	A) Recharge Li-Po battery
	B) Ducted fan is damaged	B) Check and replace ducted fan
	C) Motor is damaged	C) Check and replace motor
	D) ESC overheat protection,power reduction.	D) Landing firstly, check and select a more powerful ESC
Li-Po battery is slightly warm after charging	A) This is normal	A) The Li-Po battery may be slightly warm when fully charged. It should not be hot to the touch.
Motor vibrates excessively	A) Ducted fan is damaged	A) Check and replace ducted fan
	B) Motor is damaged	B) Check and replace motor
	C) Ducted fan is not balance	C) Adjust the ducted fan balance
	D) High speed will happen slightly vibrate	D) Its normal to use
Control surface move the wrong direction	A) Servo direction is reversed	A) Adjust servo reversing function



**Dongguan Freewing Electronic Technology Ltd**  
**HK Freewing Model International Limited**

Add.: FeiYi Building, face to Labor Bureau, Fumin Middle Road, Dalang Town,  
Dongguan City, Guangdong Province, China

Web: <http://www.sz-freewing.com>

Email: [freewing@sz-freewing.com](mailto:freewing@sz-freewing.com)

Tel: 86-769-82669669 Fax: 86-769-82033233

**东莞市飞翼电子科技有限公司**  
**香港飞翼模型国际有限公司**

地址: 广东省东莞市大朗镇富民中路402-408号飞翼楼四楼

Web: <http://www.sz-freewing.com>

Email: [freewing@sz-freewing.com](mailto:freewing@sz-freewing.com)

Tel: 86-769-82669669 Fax: 86-769-82033233

