

FMS

1/10 CHEVROLET KS BLAZER

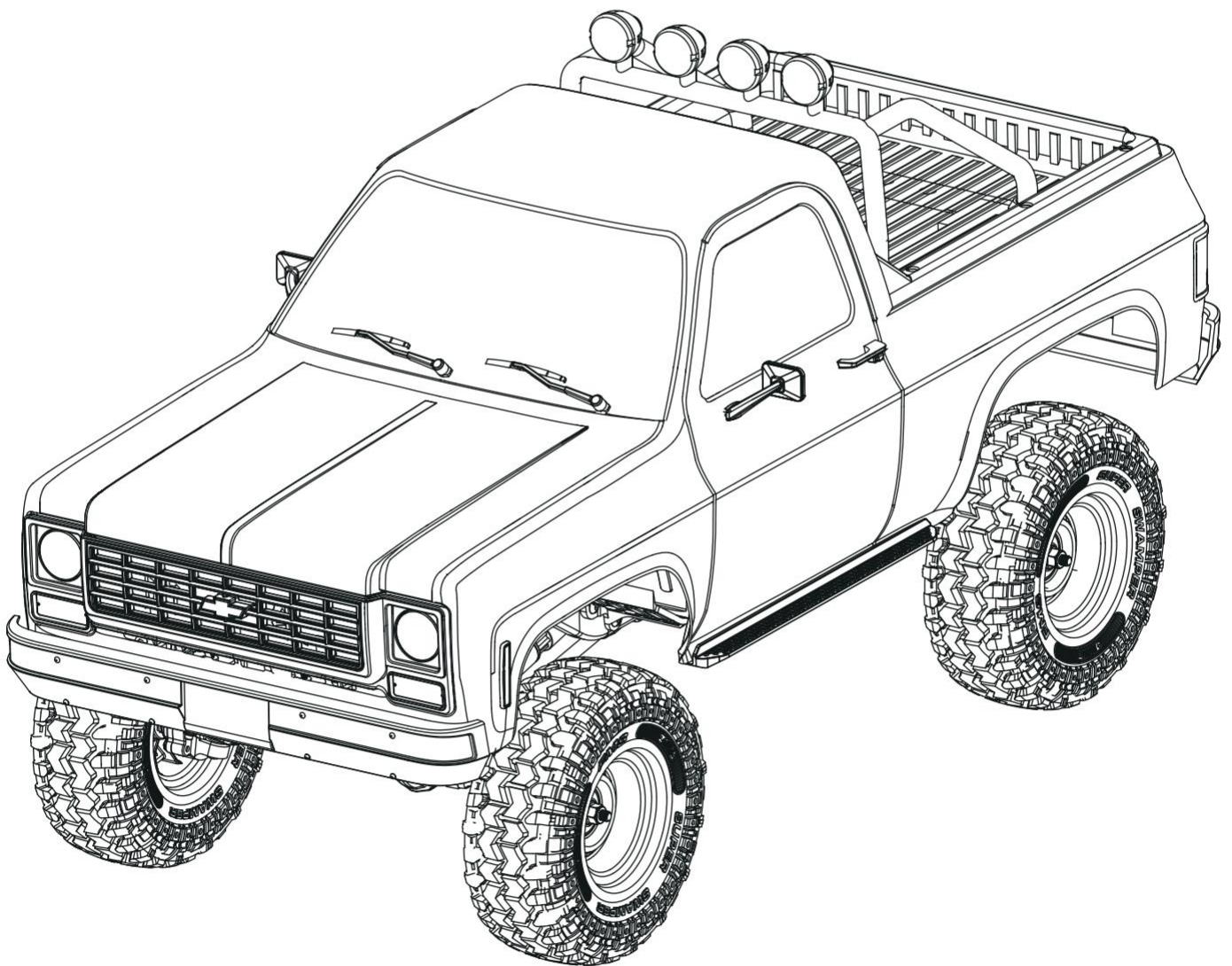

FCX10

MAN-G0268

Instruction Manual

操作手册

Disclaimer and Warning 免责声明与警告

Thank you for purchasing our product. This product is composed of precision components and is not a toy. It is not suitable for use by individuals under the age of 14. Please do not allow children to come into contact with this product. Exercise extra caution when operating this product in the presence of children. This product is a remote-controlled model and will provide a smooth and easy operating experience when the power is functioning correctly, and all components are undamaged. Visit www.fmshobby.com to access the latest product manual and related supplementary instructions and warnings. We reserve the right to update this manual. If there are updates to this manual, they will not be notified separately.

Before using the product, please carefully read this product manual to understand your legal rights, responsibilities, and safety instructions. Failure to do so may result in property damage, safety incidents, and personal safety risks. Once you use this product, it is considered that you have understood, accepted, and agreed to all the terms and content of this manual. Users are responsible for their actions and all consequences arising from them. Users commit to using this product only for legitimate purposes and agree to all the terms and content in this manual as well as any relevant policies or guidelines that our company may establish. Our company and distributors are not liable for any losses caused by users not following the product manual. In compliance with laws and regulations, our company reserves the final interpretation of this manual. Our company has the right to update, revise, or terminate these terms without prior notice.

This manual is intended to assist you in correctly operating, maintaining, and repairing the vehicle. Since most of the components involved in this product are unique parts, please keep this manual for future reference.

感谢您购买我们的产品。本产品由精密部件组成，并非玩具，因此不适合 14 岁以下的人士使用。请勿让儿童接触本产品。在有儿童出现的场景操作时请务必特别小心注意。本产品是一款遥控模型产品，在电源正常工作及各部件未损坏的情况下将提供轻松自如的操作体验。请访问以下网址www.fmshobby.com获取最新的产品手册及相关附加说明与警告。我司保留更新本手册的权力。本手册如有更新，恕不另行通知。

请务必在使用产品之前仔细阅读本产品手册，了解您的合法权益、责任和说明，否则，可能带来财产损失、安全事故和人身安全隐患。一旦使用本产品，即视为您已理解、认可和接受本手册全部条款和内容。使用者承诺对自己的行为及因此而产生的所有后果负责。使用者承诺仅出于正当目的使用本产品，并且同意本手册内的全部条款和内容及我司可能制定的任何相关政策或者准则。我司及分销商不承担因用户未按产品手册使用产品所引发的一切损失。在遵从法律法规的情况下，我司享有对本手册的最终解释权。我司有权在不事先通知的情况下，对本条款进行更新改版或终止。

本手册旨在帮助您正确操作、维护和修理车辆。由于本品所涉部件多数为特有部件，请保留本手册作为未来参考之用。

Safety, precautions and warnings 安全、预防措施及警告

- Replace damaged components with original factory-parts. Pay special attention to the polarity of all vehicle wiring.
- Use common sense when selecting the environment to operate your vehicle. Do not operate near power cables, cellular/radio towers, deep water or unstable terrain. The operator is solely responsible for their actions.
- The product is composed of precision electrical components. It is critical to keep the product away from moisture and other contaminants.
- Always check the radio range of the vehicle prior to operation in order to prevent radio loss or interference.
- Operate this product within your ability. If the vehicle is dangerous to retrieve, it never worth the risk.
- Always turn on the transmitter before connecting the battery on the model. When turning off the model, always disconnect the battery first, and then turn off the transmitter. If this order is reversed, the model may become uncontrollable and cause serious damage.
- Never allow transmitter batteries to run low as it may cause loss of vehicle control.
- Plastics on the vehicle are susceptible to damage or deformation due to extreme heat and cold climate. Do not store the model near any source of heat such as oven or heater. Store the model indoors, in a climate-controlled, room temperature environment.

- 请使用原厂部件更换损坏的部件。特别注意所有车辆接线的正负极。
- 务必选择合适的环境操作遥控模型，所选环境需远离电缆、无线电塔、深水及不稳定地形。本品操作者对其行为全权负责。
- 本品由精密电子部件构成。请勿将本品暴露于潮湿的环境或者其他污染物中。
- 确保每次操作前检查车辆的无线接收范围，以防止无线信号丢失或受干扰。
- 在您的能力范围内操作此产品。在任何时候，如果车辆操作有危险，则绝对不值得冒险。
- 通电方式：务必先开遥控器再将车子通电。断电方式：务必先将车子断电再关遥控器。以上顺序如逆转，则可能引起遥控模型失控，导致人身伤害或财产损失。
- 遥控器电池低电时，请勿操作模型车，以免出现失控。
- 模型产品上的塑胶件容易因极冷或极热气候出现变形或损坏的状况。所以请将模型产品存放在气候受控的室温环境中，切勿靠近任何热源，如烤箱或加热器等。

This product is not a toy! (14+) Recommended for ages 14 and up. Adult supervision required for ages under 14 years old. Contains small parts, keep out of reach of children 3 years of age and younger.

使用前请仔细阅读本手册。我们不对任何故意损坏或不当使用负责。这个产品不是玩具！建议14岁及以上者使用。14岁以下的用户，需要在成年人监督下使用。本产品部分包含小零件，请务必保证3岁及以下儿童不能接触本产品。

Safety symbols 安全符号

Pay close attention to the following symbols and their meanings. Failure to follow these warnings could cause damage, injury or death.

仔细阅读以下符号及其相关说明，如不按照以下指引进行操作，可能会导致设备损坏或人员伤亡。



Danger
危险

Not following these instructions may lead to serious injuries or death.

如果使用者不按照说明方法操作，有可能导致操作者或他人严重受伤，甚至遭受生命危险。

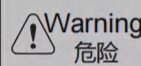

Warning
危险

Not following these instructions may lead to major injuries.

如果使用者不按照说明方法操作，有可能导致操作者或他人受到严重伤害。



Caution
危险

Not following these instructions may lead to minor injuries.

如果不按照说明方法操作，可能导致操作者或他人受到轻微伤害。

Safety guide 安全信息



Prohibited 禁止

- Do not use the product at night or in bad weather like rain or thunderstorm. It can cause erratic operation or loss of control.
- Do not use the product when visibility is limited.
- Do not use the product on rain or snow days. Any exposure to moisture (water or snow) may cause erratic operation or loss of control.
- Interference may cause loss of control. To ensure the safety of you and others, do not operate in the following places:
 - 1、Near any site where other radio control activity may occur
 - 2、Near power lines or communication broadcasting antennas
 - 3、Near people or roads
 - 4、On any body of water when passenger boats are present

- Do not use this product when you are tired, uncomfortable, or under the influence of alcohol or drugs. Doing so may cause serious injury to yourself or others.
- The 2.4GHz radio band is limited to line of sight. Always keep your model in sight as a large object can block the RF signal and lead to loss of control.
- Do not touch any part of the model that may generate heat during operation, or immediately after use. The engine, motor or speed control, may be very hot and can cause serious burns.
- Please ensure that the magnetic connectors on the chassis and car shell do not come into contact with metal objects to prevent any potential electronic short circuits!

• 请不要在夜晚或雷雨天气使用本产品，恶劣的天气环境有可能导致遥控设备失灵。

• 请不要在能见度有限的情况下使用本产品。

• 请不要在雨雪或有水的地方使用本产品。如果有液体进入到系统内部，可能会导致运行不稳定或失灵。

• 信号干扰可能导致设备失控。为保证您和他人的安全，请不要在以下地点使用本产品：

- 1、通信基站附近或其他无线电活跃的地方
- 2、人多的地方或道路附近
- 3、水域附近
- 4、高压电线或通信广播天线附近

• 当您感到疲倦、不舒服，或在摄入酒精或服食导致麻醉或兴奋的药物后，不要操作本产品。否则可能对自己或他人造成严重的伤害。

• 2.4GHz无线电波段完全不同于之前所使用的低频无线电波段。使用时请确保模型产品在您的视线范围内，大的障碍物将会阻断无线电频率信号从而导致遥控失灵模型失控。

• 请勿在操作过程中或使用后立即触摸模型可能产生热量的任何部分。发动机、电机或速度控制器可能非常热，并可能导致严重烧伤。

• 请务必确保底盘和车壳上的磁体结合件不与金属物品接触，以免引发电子短路！

Mandatory 强制

• Misuse of this product may lead to serious injury or death. To ensure the safety of you and your equipment, read this manual and follow the instructions.

• Make sure the product is properly installed in your model. Failure to do so may result in serious injury.

• Make sure to disconnect the receiver battery before turning off the transmitter. Failure to do so may lead to unintended operation and cause an accident.

• Ensure that all servos operate in the correct direction. If not, adjust the direction first.

• Make sure the model stays within the systems maximum range to prevent loss of control.

• 遥控设备使用不恰当可能导致操作者或他人严重受伤，甚至死亡。为保证您和设备的安全，请仔细阅读使用说明书并按照要求进行操作。

• 使用前必须确保本产品与模型安装正确，否则可能导致模型发生严重损坏。

• 关闭时，请务必先关闭接收机电源，然后关闭发射机。如果关闭发射机电源时接收机仍然在工作，将有可能导致遥控设备失控或者引擎继续工作而引发事故。

• 操控时，请先确认模型所有舵机的动作方向与操控方向一致。如果不一致，请调整好正确的方向。

• 当遥控距离较远时，有发生失控的可能，请适当缩短遥控距离。

DoC Declaration

Hereby, [Flysky Technology Co., Ltd.] declares that the Radio Equipment [FS-MG11-BS], [FS-R11D-ESC-BS]、[FS-DB01] is in compliance with RED 2014/53/EU.

The full text of the EU DoC is available at the following internet address: www.flyskyttech.com/info_detail/10.html

CE Warning

The antenna(s) used for this transmitter must be installed to provide a separation distance of at least 20 cm from all persons and must not be co-located or operating in conjunction with any other transmitter. End-users and installers must be provided with antenna installation instructions and transmitter operating conditions for satisfying RF exposure compliance.

FCC Statement

This equipment has been tested and found to comply with the limits for a Class B digital device pursuant to part 15 of the FCC rules. These limits are designed to provide reasonable protection against harmful interference in a residential installation. This equipment generates, uses and can radiate radio frequency energy and, if not installed and used in accordance with the instructions, may cause harmful interference to radio communications. However, there is no guarantee that interference will not occur in a particular installation. If this equipment does cause harmful interference to radio or television reception, which can be determined by turning the equipment off and on, the user is encouraged to try to correct the interference by one or more of the following measures:

- Reorient or relocate the receiving antenna.
- Increase the separation between the equipment and receiver.
- Connect the equipment into an outlet on a circuit different from that to which the receiver is connected.
- Consult the dealer or an experienced radio/TV technician for help.

To assure continued compliance, any changes or modifications not expressly approved by the party responsible for compliance could void the user's authority to operate this equipment.

This equipment complies with Part 15 of the FCC Rules. Operation is subject to the following two conditions:

- (1) This device may not cause harmful interference.
- (2) This device must accept any interference received, including interference that may cause undesired operation.

Caution!

The manufacturer is not responsible for any radio or TV interference caused by unauthorized modifications to this equipment. Such modifications could void the user authority to operate the equipment.

1. The antenna(s) used for this transmitter must be installed to provide a separation distance of at least 20 cm from all persons and must not be co-located or operating in conjunction with any other transmitter. End-users and installers must be provided with antenna installation instructions and transmitter operating conditions for satisfying RF exposure compliance.

2. Move all your channels to the desired position.
3. Select [All channels] and then [Yes] in the confirmation box.

Environmentally friendly disposal

Old electrical appliances must not be disposed of together with the residual waste, but have to be disposed of separately. The disposal at the communal collecting point via private persons is for free. The owner of old appliances is responsible to bring the appliances to these collecting points or to similar collection points. With this little personal effort, you contribute to recycle valuable raw materials and the treatment of toxic substances.

CAUTION

RISK OF EXPLOSION IF BATTERY IS REPLACED BY AN INCORRECT TYPE.
DISPOSE OF USED BATTERIES ACCORDING TO THE INSTRUCTIONS



Background 产品背景

The Chevrolet K5 Blazer made its debut in 1969 amidst fierce competition. As a challenger to the Ford Bronco, it immediately captured global attention with its rugged off-road capabilities and reliable performance. As one of the iconic models in the Chevrolet SUV lineup, the K5 Blazer quickly gained popularity among off-road enthusiasts and family users.

The K5 Blazer is renowned for its outstanding off-road performance and reliability. Its four-wheel drive system, high ground clearance, and sturdy chassis allow it to conquer various terrains and extreme environments. Whether it's rough mountain roads or muddy swamps, the K5 Blazer moves forward with confidence. Additionally, it offers a spacious interior, allowing for multiple passengers and carrying a large amount of cargo, making it an ideal choice for both family use and adventure. In on-screen depictions, it can be seen escaping dire situations in "Jurassic Park," and engaging in intense car chases in "Die Hard", but also enjoying leisurely outings in "Modern Family."

Whether conquering limits on rugged mountain roads or showcasing individuality on city streets, the Chevrolet K5 Blazer embodies our desire for freedom, adventure, and self-expression. It is not just a vehicle; it represents a way of life. With its classic design, such as the upright front grille and square body lines, it has become part of American automotive culture.

Chevrolet K5 Blazer于1969年首次问世，诞生于一片激烈的竞争之中。作为对手Ford Bronco的挑战者，它以坚固的越野能力和可靠的性能立即吸引了全球的目光。作为Chevrolet SUV系列的标志性车型之一，K5 Blazer迅速赢得了越野爱好者和家庭用户的青睐。

K5 Blazer以其卓越的越野性能和可靠性而闻名。四轮驱动系统、高离地间隙和坚固的底盘使它能够征服各种地形和极端环境。无论是崎岖山路还是泥泞沼泽，K5 Blazer都能坚定地前行。此外，它还提供宽敞的内部空间，允许乘坐多人和携带大量货物，成为家庭用车和冒险探险的理想之选。因此，他既可以在《侏罗纪公园》中载着人们绝处逢生逃离恐龙园，在《虎胆龙威》中载着主角与恐怖分子展开激烈的追逐和对抗，也可以出现在《摩登家庭》中载着全家出门度假。

无论是在崎岖山路上征服极限，还是在城市街道上展现个性，Chevrolet K5 Blazer承载着人们对自由、冒险和自我表达的向往。它不仅仅是一辆汽车，更是一种生活方式的象征。这款车型的经典设计，如直立的前脸和方正的车身线条，使其成为美国汽车文化的一部分。

About Model 产品介绍

Authorized by General Motors, the FMS model presents the 1/10 scale Chevrolet K5 BLAZER using the new FCX10 simulated climbing chassis, which recaptures the off-road performance of the original vehicle.

The FCX10 is FMS's first high-performance 1/10 simulated climbing chassis. Simulated climbing vehicles in various scales have been popular for many years and have a large number of enthusiasts around the world. Major brands have also introduced model vehicles with different styles and distinctive structures. As a young brand in the remote control model car field, FMS strives for innovation and improvement, learning and building on from the strengths of our competitors. The FCX10 chassis has launched after two years of development. It is compact, powerful, easy to maintain, and delivers outstanding performance.

The FCX10 chassis features a mainstream mid-front motor layout and four-link suspension, along with portal axle assemblies for both the front and rear solid axles and differentials that can be individually locked using the remote control. On the FCX10 chassis, we have redesigned the axle housing structure from previous FMS models, added lateral structural support, and dispersed stress to reduce the likelihood of axle housing breakage during routine jumps and inclines. The redesigned axle structure is more compact, resulting in increased ground clearance and improved off-road capability. The mid-front motor and transmission, as an integral unit, have a lower center of gravity compared to similar products, resulting in a lower rolling center and reduced likelihood of rollovers.

There are generally two main approaches to the design of the transmission system. One is the full-time four-wheel drive with "DIG" function, which focuses more on maximizing climbing performance. The other is the selectable switch FD/4WD/RD, which aims to simulate the driving characteristics of real vehicles and experience the vehicle's different motion behaviors in various modes. The "DIG," also known as "tank turning," is a high-level feature typically found in competitive climbing vehicles. It currently appears in large-scale climbing vehicles and certain high-end custom products. The FCX10 officially introduces "DIG" as a standard feature in its 1/10 scale product lineup. By simply opening the transmission and changing the installation position of the coupler inside, the user can easily switch from the default FWD/4WD/DIG setting to FWD/4WD/RWD mode, thus catering to both climbing and competition-oriented users as well as users who prefer multiple drive modes.

The transmission symmetrically places four metal-gear waterproof servos on both sides, which respectively control the shifting between high and low gears, switching between the three drive modes, and the differential lock for the front and rear axles. The battery compartment is located at mid-rear of the vehicle, resulting in a lower center of gravity compared to its competitors. It can accommodate commonly used 2-3S lithium batteries for 1/10 scale cars, not being restrictive to the direction of the battery's terminal. It is highly compatible with the majority of hardshell or soft pack batteries. Additionally, the battery compartment can be flipped backward or quickly detached, and all electronics are centralized in the middle of the vehicle, making daily maintenance and replacement very convenient.

Long-term fans of FMS will be glad to know that our high standards for appearance have not been neglected in this pursuit of excellent performance. In addition to the electroplated front and rear bumpers and grille, special craftsmanship stickers have been applied to restore the chrome-plated lines on the sides of the car body. The vehicle comes pre-installed with headlights, front turn signals, side turn signals, rear turn signals, reverse lights, and other lighting components. The car shell uses a magnetic interface to draw power from the chassis, allowing the lights of the entire vehicle to be activated with a single button on the remote control. Additionally, a detachable rear cargo cover and roll cage kit are provided as a bonus, providing the option to switch between SUV and pickup configurations.

The FCX10 K5: Explore the unknown, enjoy your freedom, and conquer challenges!

由通用汽车公司授权，FMS模型出品的这款1/10模型车Chevrolet K5 BLAZER，采用FCX10仿真攀爬底盘，忠实还原了原车的越野性能。

FCX10是FMS第一款高性能1/10的仿真攀爬底盘。各种比例的仿真攀爬车已风靡多年，在世界各地都拥有众多拥趸，各大品牌也顺势推出风格各异，结构各具特色的车型。作为遥控模型车领域的年轻品牌，FMS在学习各家所长的基础上力求创新和改良，历时2年打磨出这款布局紧凑、功能强大、维护方便、性能出众的FCX10底盘。

首先整个底盘采用主流的中前置动力布局，四连杆悬挂，配备有门式结构轮边减速器的前后直桥，以及可以用遥控器分别锁止的前后差速器。作为高性能攀爬车的标配，“门桥”已是司空见惯，但在FCX10上我们重新设计了桥壳结构，增加了横向结构支撑，分散了应力，日常飞坡小跳不易发生断桥事故。而本桥结构被设计得更加紧凑，换来更高离地间隙，通过性更好。中前置电机和变速箱作为一个整体，重心比同级产品更低，滚动重心也更低，更不易侧翻。变速箱的功能设计思路大致有两个派系，一个是全时四轮驱动加“断传”，更偏向榨取攀爬性能；一个是可以切换前驱/四驱/后驱，更偏向对真车驱动形式的仿真，体会不同模式下车辆的运动姿态。“断传”也被坊间称之为“坦克掉头”，是竞技类攀爬车才具备的高阶功能，目前也在大比例攀爬车和个别高定产品上出现，而FCX10将“断传”正式作为1/10产品标配登场。但不同驱动模式（前驱/四驱/后驱）可以模拟各类越野车的行驶特性，一键切换的魅力也让人难以取舍……成年人的玩法是，不做取舍，“既要”“也要”！在出厂默认状态下变速箱具备一键切换（前驱/四驱/断传），此时车辆没有后驱功能，但只需将变速箱打开，调换里面耦合器的安装位置即可转换为一键切换（前驱/四驱/后驱）模式。如此无论是攀爬竞技向用户还是多种驱动模式向用户都能兼顾。

变速箱的两侧对称布置4颗金属齿防水溅舵机，分别控制高低速档位切换、三种驱动模式切换、以及前后车桥差速锁。电池舱中后置，与竞品相比重心更低，可容纳各类1/10车常见的2-3S锂电，对出线方向不敏感，绝大部分硬壳或软包电池都能使用，兼容度很高。此外电池舱可向后翻起或“快拆”，所有电子设备都集中在车辆中部，日常检修维护或者拆换都非常方便。

大多大比例攀爬车的体验取向型和性能取向型的玩家并不太在意外观的像真度，但FMS的原则一贯是，你可以不要，我不能不给。除了电镀格栅、前后保险杠以外，1/10 K5还使用特殊工艺贴纸还原侧面镀铬线条；出厂大灯，前转向灯，两侧转向灯，后转向灯，倒车灯等均已预装完毕，车壳采用磁吸接口从底盘取电，遥控器一键唤醒全车灯光表达；此外还附赠可拆卸后斗覆盖件和防滚架套件，SUV和PICKUP可随意切换。

FCX10 K5，与自由相遇，与冒险为伍，探索未知，征服挑战！

Features 特点

- READY SET
 - FCX10 SIMULATED CLIMBING CHASSIS
 - GENERAL MOTORS CHEVROLET-AUTHORIZED K5 BODY SHELL
 - RIGID METAL GIRDER
 - METAL THREADED SHOCK ABSORBERS
 - METAL GEARS FULL SET
 - BALL BEARINGS FULL SET
 - PORTAL AXLES (METAL GEAR)
 - FOUR-LINK SUSPENSION
 - THREE-POSITION SWITCH BETWEEN“DIG/4WD/FD” OR BETWEEN“FD/4WD/RD”(MANUAL SETTING REQUIRED)
 - FRONT AND REAR DIFFERENTIALS CAN BE INDIVIDUALLY REMOTE-CONTROLLED AND LOCKED
 - TWO-SPEED TRANSMISSION
 - FACTORY PRE-INSTALLED LIGHTS (EXCEPT FOR THE ROLL CAGE FOG LIGHTS) , WITH THE SHELL POWERED BY MAGNETIC INTERFACE FROM THE CHASSIS, AND THE REMOTE CONTROL CAN INSTANTLY ACTIVATE ALL LIGHTS
 - INCLUDES DETACHABLE CARGO COVER AND ROLL CAGE KIT, ALLOWING FOR EASY SWITCHING BETWEEN SUV AND PICKUP CONFIGURATIONS
 - 550 BRUSHED MOTOR
 - 2.4GHZ 11CH REMOTE CONTROL SYSTEM
-
- RS组装完成品
 - FCX10仿真攀爬底盘
 - 通用雪佛兰授权K5仿真车壳
 - 金属大梁
 - 金属绞牙避震器
 - 全车金属齿轮
 - 全车滚珠轴承
 - 门式车桥（金属齿）
 - 四连杆悬挂
 - 三档开关切换“断传/四驱/前驱”标准出厂动力输出模式，也可手动设置成“后驱/四驱/前驱”动力输出模式。
 - 前后差速器可分别遥控锁止
 - 高低速换挡
 - 出厂预安装全车灯珠（防滚架雾灯除外），车壳采用磁吸接口从底盘取电，遥控器一键唤醒全车灯光表达
 - 附赠可拆卸后斗覆盖件和防滚架套件，SUV和PICKUP可随意切换
 - 550有刷电机
 - 2.4GHz 11通道遥控系统

Specification 产品参数

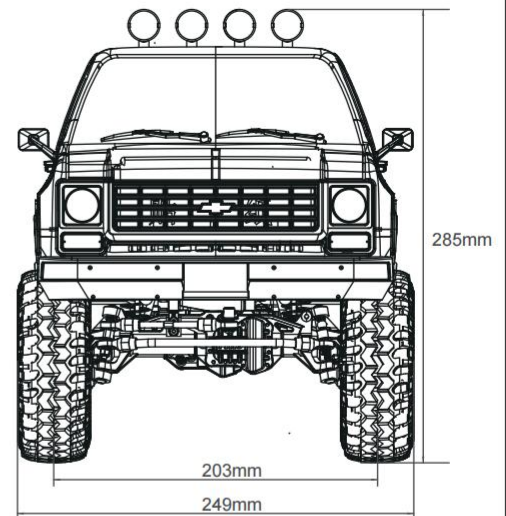
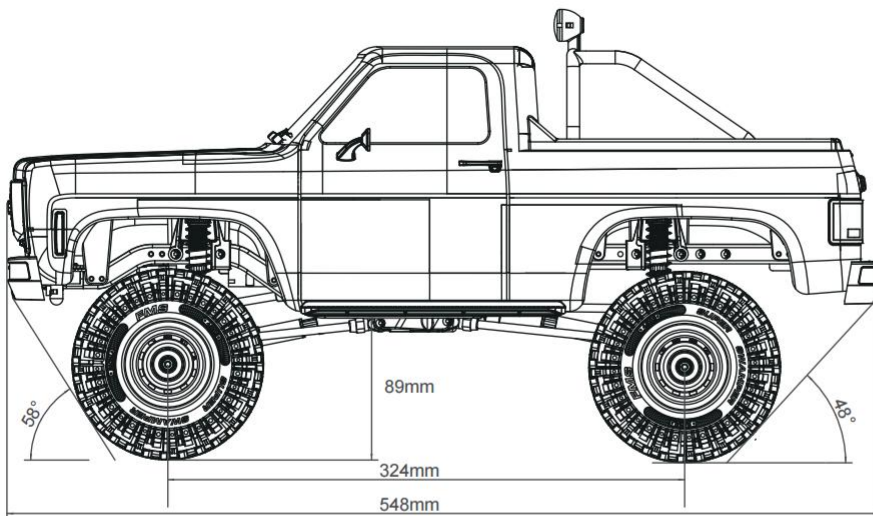

- Length: 548mm
- Width: 249mm
- Height: 285mm
- Wheelbase: 324mm
- Tire F/R : Φ 46*120mm
- Minimum Ground Clearance: 89mm
- Approach Angle: 58°
- Departure Angle: 48°

- 车长: 548mm
- 车宽: 249mm
- 车高: 285mm
- 轴距: 324mm
- 轮胎: Φ 46*120mm
- 离地间隙: 89mm
- 接近角: 58°
- 离去角: 48°

- Motor: 550 BRUSHED MOTOR
- Recommended Battery : 2S Lipo 7.4V 2000mAh x1
- Remote control distance: 150m
- Remote control: 2.4GHZ 11CH REMOTE CONTROL SYSTEM

- 电机: 550有刷电机
- 推荐电池: 2S Lipo 7.4V 2000mAh
- 遥控距离: 150m
- 遥控: 2.4GHz 11通道遥控系统

Transmitter Intruction 发射机介绍

The FS-MG11-BS is a 11-channel transmitter that adopts the 2.4GHz 2A-BS Automatic Frequency Hopping Digital System. The transmitter is lightweight and compact in design, comfortable and ergonomic. The transimtter supports ESC parameters setting and compatible with variety of car models..

FS-MG11-BS 是一款使用 2.4GHz 2A-BS 版自动跳频数字系统的发射机，输出十一通道，外观轻巧，手感舒适，符合人体工程学，支持通过发射机设置电调参数，适配车模型使用。

Transmitter Overview 发射机概览

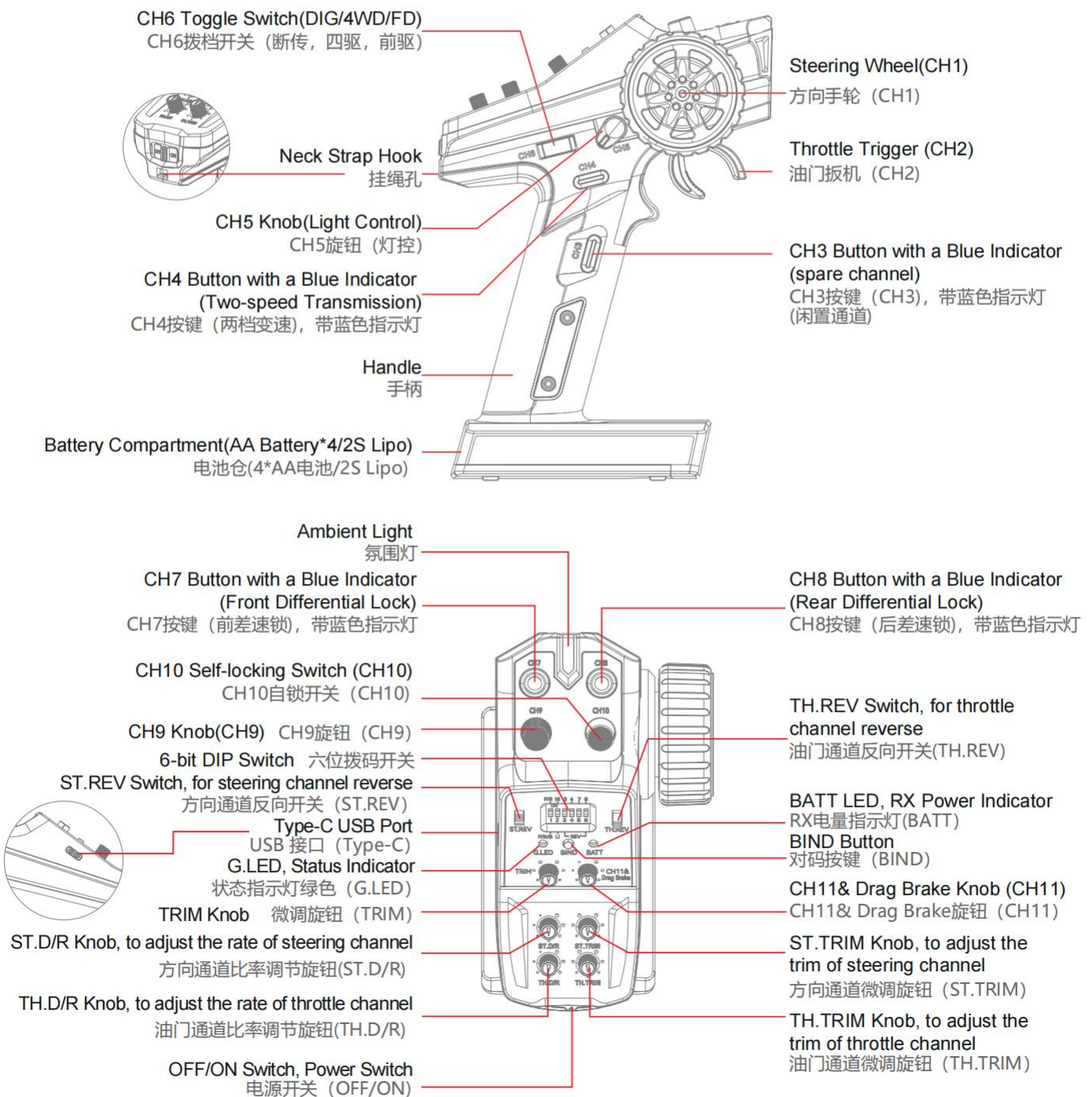

Getting Started 使用前准备

Before operation, install the battery and connect the system as instructed below.

开始操作前，请按照本章的顺序和指引安装电池、连接设备。

Transmitter Antenna 发射机天线

The transmitter has a built-in antenna. When the transmitter starts to work, the antenna automatically operate, without additional operations.

本发射机天线为内置天线，发射机开始工作，天线自动工作，

Receiver and Servo Installation 接收机与舵机安装

Make sure that the receiver is mounted in an appropriate location within the model, to ensure a stable signal, maximum range and to mitigate external interference, follow these guidelines:

Pay attention to the following when installing the receiver:

1. Make sure the receiver is not installed near motors or sources of electrical noise.
2. Keep the receiver's antenna away from conductive materials such as carbon or metal. To ensure normal function, make sure there is a gap of at least 1cm between the antenna and the conductive material.

请结合相应模型的结构选择合适的位置安装接收机，同时为了确保接收机的性能和遥控距离的稳定，并防止外界干扰，请注意以下操作事项：

安装过程中请注意以下事项：

1. 确保接收机安装在远离电机，或电子噪声过多的区域。
2. 接收机天线需远离导电材料，例如金属棒和碳纤物质。为了避免影响正常工作，请确保接收机和导电材料之间至少有 1 厘米以上的距离。



Caution
注意

To prevent damage do not power on the receiver during installation.





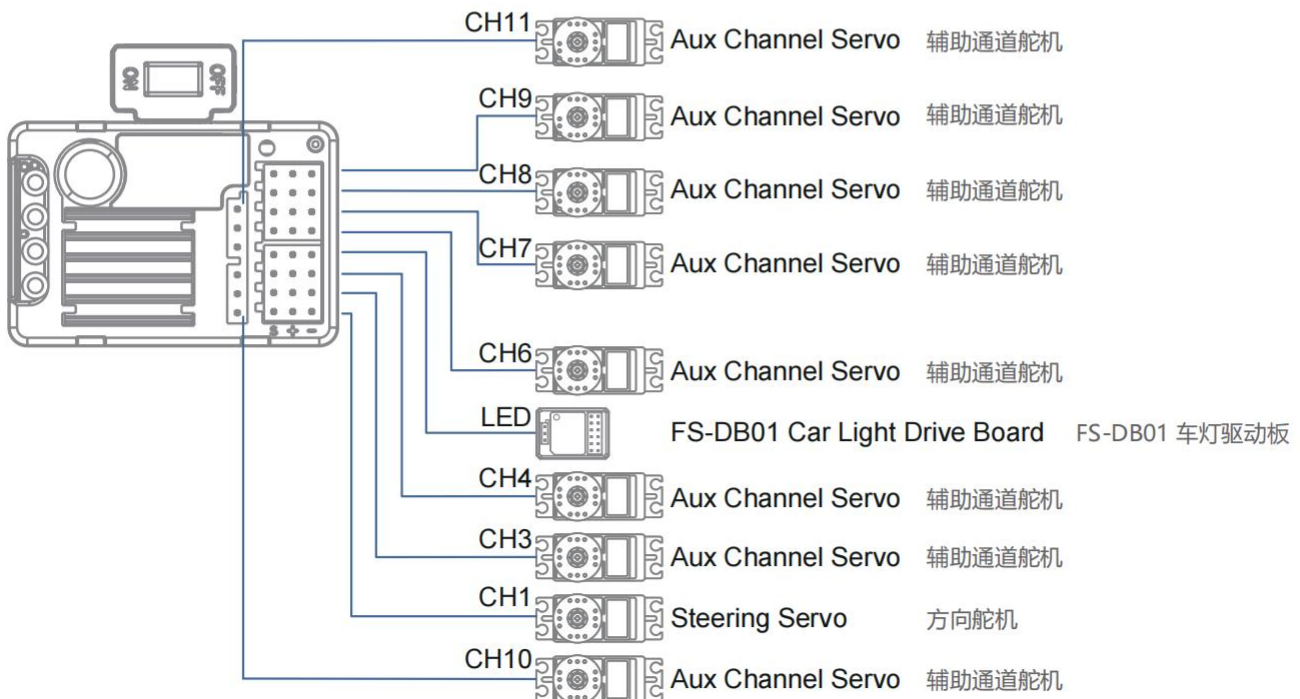

准备过程中，请勿连接接收机电源，避免造成不必要的损失

Connect the servos/car light drive board to the receiver according to the digram below

请参考如下图示来连接接收机与舵机 / 灯板：



Transmitter Battery Installation 发射机电池安装

 Danger 注意	Only use specified battery (X4 AA batteries). 仅使用厂家指定的电池。
 Danger 注意	Do not open, disassemble, or attempt to repair the battery. 请勿打开、拆卸或自行维修电池。
 Danger 注意	Do not crush/puncture the battery, or short the external contacts. 请勿挤压、刺穿或接触电池的金属端子。
 Danger 注意	Do not expose to excessive heat or liquids. 准请勿将电池置于高温环境或液体中。
 Danger 注意	Do not drop the battery or expose to strong shocks or vibrations. 请注意防止电池跌落、碰撞或振动。
 Danger 注意	Always store the battery in a cool, dry place. 请将电池存放在干燥阴凉的环境中。
 Danger 注意	Do not use the battery if damaged. 如果电池损坏，请立即停止使用。

Installing the AA Battery

Follow the steps below to install the AA batteries:

1. Open the battery compartment cover as illustrated.
2. Insert 4 fully-charged AA batteries into the compartment. Make sure that the batteries are well set according to the polarities marked on the battery compartment.
3. Replace battery compartment cover.

Installing the LiPo Battery

Follow the steps below to install the LiPo battery:

1. Open the battery compartment cover.
2. Insert 2S fully-charged LiPo battery into the compartment.
3. Plug the cable of LiPo battery into the JST Jack. Make sure to connect correctly according to the polarities marked on the battery compartment.
4. Replace battery compartment cover. Be careful not to pinch the cable.

AA 电池安装

请按照以下步骤安装 AA 电池：

1. 打开电池仓盖（如图所示）；
2. 将 4 颗电量充足的电池按标注的极性方向装入电池仓内；
3. 盖好电池仓盖。

LiPo 锂电池安装

请按照以下步骤安装锂电池：

1. 打开电池仓盖。
2. 将 2S 电量充足的锂电池放入电池仓内，
3. 将电池连接线接入 JST 接口，确保正确连接正负极；
4. 盖好电池仓盖，注意不要夹到电池连接线。



Instructions 操作指引

After setting up, follow the instructions below to operate the system.

准备操作完成后，您可以按照本章指引开始使用本产品。

Power On 开机

Follow the steps below to turn on the transmitter:

1. Check to make sure that the batteries are fully charged and installed correctly.
2. Toggle the Power Switch to the ON position. The G.LED will be solid on, both the ambient light and the BATT LED will be on for 3 seconds, and then will be off.

Note: For safety, always power on the transmitter before the receiver.

请按照以下步骤进行开机：

1. 检查系统状态，确保电池电量充足且安装正确
2. 将电源开关拨到 [ON] 位置，G.LED 指示灯常亮，氛围灯和 BATT 指示灯亮 3 秒后灭。

注：为保障模型及人员安全，使用时请先打开发射机再给接收机通电。



Warning
警告

Operate with caution in order to avoid damage or injury.
此时系统已启动，请谨慎操作，否则可能导致产品损坏或人员伤亡。

LED Indicator LED 指示

The G.LED of the transmitter is used to indicate the functional status of the transmitter; The ambient light and BATT LED are used to indicate the power status of the transmitter and the power status of the receiver, the details are as follows.

1. G.LED: The green status indicator
 - When the transmitter is in binding state, the G.LED will flash rapidly.
 - When the transmitter voltage is low, the G.LED will flash slowly.
 - When the transmitter is in idle alarm state, the G.LED will be in gradual light state.
 - When the transmitter is in end point adjustment status, the G.LED will work in two-flash-one-off state.
2. BATT Indicator: The battery power indicator for the transmitter or the 2-in-1 receiver
 - When the battery power is high, the BATT LED will be solid on in green.
 - When the battery power is medium, the BATT LED will be solid on in yellow.
 - When the battery power is low, the BATT LED will be solid on in red.
 - When the battery power is ultra low, the BATT LED will flash slowly in red.

Note: In three seconds after the power-on of the transmitter, the ambient light and BATT LED indicate the transmitter battery power status. When the transmitter is powered on for 3 seconds, the transmitter battery power status is indicated in case of binding a standard receiver. The receiver battery power status is indicated in case of binding 2-in-1 receiver.

- When the transmitter does not receive the return signal, the ambient light and BATT LED will be off.
- When the receiver is de-bound, the ambient light and BATT LED will maintain in the state when the receiver is de-binding.

本发射机的 G.LED 用于指示发射机功能状态；氛围灯与 BATT 指示灯用于指示发射机电池电量状态及接收机回传的电池电量状态，具体如下：

1. G.LED: 绿色状态指示灯

- 快闪：对码状态
- 慢闪：电压低
- 呼吸灯：闲置状态
- 二闪一灭：舵量设置

2. 氛围灯；BATT：发射机 / 二合一接收机电池电量状态指示灯

- 绿色常亮：电压高
- 黄色常亮：电压中
- 红色常亮：电压低
- 红色慢闪：电压超低

注：发射机开机后前 3 秒，氛围灯和 BATT 指示灯指示发射机电池电量状态；当发射机开机 3 秒后，若对码标准接收机则指示发射机电池电量状态；若对码二合一接收机，则指示接收机电池电量状态：

- 未收到接收机回传信号时，氛围灯和 BATT 指示灯灭
- 接收机掉码时，氛围灯和 BATT 指示灯则保持掉码时状态

Binding 对码

The transmitter and the receiver have been pre-bound before delivery. If you are going to use another receiver, follow the steps below to rebind. The transmitter supports two-way binding, the steps are as following:

1. Turn on the transmitter while holding the BIND button, then the transmitter will enter the binding mode. At this time, the G.LED will flash quickly. Once in bind mode release the BIND button.
2. Turn on the receiver, and it will wait for 1 second for connection. If without connection, the receiver will enter the binding mode automatically.
3. Once the binding is successful, the receiver LED and the G.LED of the transmitter will be solid on.
4. Verify that the transmitter and the receiver are working properly. If you need to re-bind, repeat the above steps.

Notes:

1. Applicable to the FS-MG11-BS transmitter and the FS-R11D-ESC-BS receiver.
2. The FS-MG11-BS transmitter complies with the 2A-BS protocol and is only compatible with receivers conforming to this protocol.
3. Different receivers have different bind procedures. For more information, visit the FLYSKY website for manuals and other related information.

本发射机和接收机在出厂前已对码成功。若需使用其他的接收机，请按照如下步骤进行对码。本发射机支持双向对码，对码步骤如下：1. 将发射机按住对码按键（BIND）开机即进入对码状态，此时 G.LED 指示灯快闪，松开对码按键；2. 接收机上电等待 1 秒没有连接即自动进入对码状态，此时接收机 LED 快闪；3. 对码成功后，接收机 LED 指示灯及发射机 G.LED 指示灯常亮；4. 检查发射机、接收机是否正常工作。如需重新对码，请重复以上步骤。

注：

1. 此对码步骤仅适用于 FS-MG11-BS 发射机与 FS-R11D-ESC-BS 接收机对码；
2. FS-MG11-BS 发射机采用 2A-BS 协议，只兼容该协议的接收机。
3. 不同的接收机对码方式不同，具体对码方式请访问 FLYSKY 官网查询接收机说明书或其他相关资料。

Stick Calibration 摇杆校准

Use this function to correct for the mechanical deviation of the throttle trigger, steering wheel and CH5 knob, for example, deviation occurred in the self-centering or maximum minimum travel, the steps are as following:

1. Turn and hold the steering wheel clockwise to the max travel point and push the throttle trigger forwards as far as possible, and at the same time turn on the transmitter, the transmitter will be in calibration mode, meanwhile, the buzzer will sound three times for prompt.
2. Steering Wheel Calibration: Turn the steering wheel to the max and min travel point clockwise/counterclockwise respectively, and the buzzer will sound two times for prompt.
3. Throttle Trigger Calibration: Push/pull the throttle trigger to forward/backward as far as it will go, and the buzzer will sound once for prompt.
4. CH5 Knob Calibration: Turn the CH5 knob to its max and min travel point clockwise/counter-clockwise respectively, and the buzzer will give a long beep.
5. Press the BIND button to save and exit in case of the calibration is successful, and the buzzer will give a long beep.

*If the calibration fails, pressing the BIND button is invalid. Repeat the steps above.

当油门、手轮和 CH5 旋钮发生机械性偏离，如回中或最大 / 最小行程出现偏差时，使用此功能修正。步骤如下：

1. 同步将手轮顺时针打到最大、扳机往前推到底并开机，进入校准模式，发射机蜂鸣器响 3 声提示；
2. 手轮校准：将手轮分别按顺时针和逆时针方向转至最大和最小行程，发射机蜂鸣器响 2 声提示；
3. 扳机校准：将扳机分别向前和向后推至最大和最小行程，发射机蜂鸣器响 1 声提示；
4. CH5 旋钮校准：将 CH5 旋钮分别按顺时针和逆时针方向转到最大和最小行程，发射机蜂鸣器长响 1 声提示；
5. 按 BIND 键退出并保存校准数据，发射机蜂鸣器长响 1 声提示。

*若校准失败，按 BIND 键无反应，请重复以上校准步骤。

Power Off 关机

Follow the steps below to turn off the system:

1. Turn off the receiver first.
2. Toggle the transmitter's power switch to the [OFF] position.

请按以下步骤关闭发射机:

1. 先断开接收机电源;
2. 将电源开关拨到 [OFF] 位置, 关闭发射机。



Make sure to disconnect the receiver power before turning off the transmitter. Failure to do so may lead to damage or serious injury.

关闭时, 请务必先关闭接收机电源, 再关闭发射机, 否则可能导致模型损坏、人员受伤。

System Functions 系统功能

This section focuses on the functions and how to use them.

此章节主要介绍系统各项功能操作。

Channel Description 通道说明

The transmitter outputs a total of 11 channels, which are assigned as below, as well as the functions.

该发射机共输出 11 个通道, 控件分配及相关功能如下:

Channel 通道	Assigned Control 已分配的控件	Function 功能
CH1	Steering Wheel 方向手轮	Steering, to make the model car to turn right or left. Turn the steering wheel in clockwise or counterclockwise to control the left/right steering. 方向, 控制车子左右转向。沿顺时针或逆时针方向旋转手轮, 可控制车子左右转向。
CH2	Throttle Trigger 油门扳机	Throttle, to control the model car to move forward or backward. Push or pull the throttle trigger to control the model car forward or backward. 油门, 控制车子前后行驶。推或扣油门扳机控制车子前进或后退。
CH3	CH3 Button CH3 按键	User can customize the channel function. For example, function as a fast / slow position servo channel. 可自定义通道功能, 如可作为快慢档舵机通道。
CH4	CH4 Button CH4 快慢档	TWO-SPEED TRANSMISSION 两档变速
CH5	CH5 Knob CH5 灯控	For the 2-in-1 receiver, it controls car lights, and for the standard receiver, it can be customized the channel function. 控制车灯 (二合一接收机), 也可自定义通道功能 (标准接收机)。
CH6	CH6 For Switching Between FD/4WD/DIG CH6 切换 前驱/四驱/断传	For Switching Between FD/4WD/DIG 切换 前驱/四驱/断传
CH7	CH7 Front Differential Lock CH7 前差速锁	Front Differential Lock 前差速锁
CH8	CH8 Rear Differential Lock CH8 后差速锁	Rear Differential Lock 后差速锁
CH9	CH9 Knob CH9 旋钮	User can customize the channel function. For example, function as a fast / slow position servo channel. 可自定义通道功能, 如可作为快慢档舵机通道。
CH10	CH10 Self-locking Switch CH10 自锁开关	
CH11	CH11 & Drag Brake Knob CH11 & Drag Brake 旋钮	For the 2-in-1 receiver, it is used to set the ESC drag brake, and for the standard receiver, it can be customized the channel function. 设置电调刹车力度 (二合一接收机), 也可自定义通道功能 (标准接收机)。

Channel Reverse 通道反向

This function reverses the motion direction of steering channel, throttle channel, CH3, CH4, CH7 and CH8 servos. The ST.REV and TH.REV switches are reverse setting switches of steering channel and throttle channel respectively. Switches 3, 4, 5 and 6 of the 6-bit DIP switch are the reverse setting switches of CH3, CH4, CH7, and CH8, respectively. A switch on the upper side indicates that the servo output is normal; a switch on the lower side indicates that the servo output is reverse.

Setup:

Toggle the corresponding setting switch to the upper side, the buzzer will have one beep. Toggle the switch to the lower side, the buzzer will have two beeps.

该功能可将方向通道、油门通道、通道 3、通道 4、通道 7 和通道 8 舵机的动作方向反转。

ST.REV 开关和 TH.REV 开关分别为方向通道、油门通道反向设置开关。六位拨码开关第 3、4、5 和 6 位开关分别为通道 3、通道 4、通道 7 和通道 8 反向设置开关。开关在上侧，表示舵机输出为正向；开关在下侧，表示舵机输出为反向。

功能设置：

将对应的设置开关拨至上侧，蜂鸣器响一声提示；将开关拨至下侧，蜂鸣器响两声提示。

Trims 微调设置

This function can set the trims of steering channel, throttle channel, channel 4 and channel 6.

CH6 Trim Adjustment

To adjust the trim of channel 6. The step is 5us, and setting range is from -120us to +120us.

Setup:

1. In the power-on state, rotate the steering wheel clockwise to its maximum point, and at the same time press BIND twice (within 1S) to enter the channel 6 trim setting state.
2. Press the CH7 button to decrease the trim value, when pressing CH7 once, the buzzer will sound once for prompt, and when it reaches the minimum value of -120us, the buzzer will be turned off.
3. Press the CH8 button to increase the trim value, when pressing CH8 once, the buzzer will sound once for prompt, and when it reaches the maximum value of 120us, the buzzer will be turned off.
4. Long press BIND for 1 second or restart the transmitter to exit the trim setting state. At this time, the buzzer will give a long beep.

Trim Adjustment for Steering Channel, Throttle Channel and CH4

To adjust the trims of steering channel, throttle channel and channel 4.

The ST.TRIM, TH.TRIM and TRIM knobs correspond to the trim adjustments of the steering channel, throttle channel and CH4, respectively. When the knob is centered by default, the trim value is zero. When adjusting counterclockwise, the trim value increases to a maximum of 120us. When adjusting clockwise, the trim value decreases to a minimum of -120us. Note that when the channel is set in reverse, the trim is reversed at the same time, that is, the trim value decreases in the counterclockwise adjustment, and the trim value increases in clockwise adjustment.

Setup:

Turn the trim knobs corresponding to the channel clockwise or counterclockwise for trim adjustment. The buzzer will have one beep when the position is reached to the center.

Note: After the throttle trim is changed, the receiver needs to be re-powered on to recognize the new throttle neutral. Otherwise, an exception may occur during vehicle reversing.

该功能可设置方向通道、油门通道、通道 4 和通道 6 的微调。

通道 6 微调调节

调节通道 6 微调。设置步进 5us，设置范围 -120us~+120us。

功能设置：

1. 开机状态下，顺时针旋转方向手轮至最大，同时双击 BIND 键（1S 内）即进入通道 6 微调设置状态；
2. 按 CH7 按键减小微调值，按一下则蜂鸣器响一声提示，至最小值 -120us 时，蜂鸣器关闭；
3. 按 CH8 按键增大微调值，按一下则蜂鸣器响一声提示，至最大值 120us 时，蜂鸣器关闭；
4. 长按 BIND 键 1S 或重启发射机即可退出微调设置状态，此时，蜂鸣器长响一声提示。

System Functions 系统功能

方向通道、油门通道和通道 4 微调调节

调节方向通道、油门通道和通道 4 微调。

ST.TRIM、TH.TRIM 和 TRIM 旋钮分别对应方向通道、油门通道和通道 4 微调调节。默认旋钮居中时，微调值为 0。逆时针调节时，则增大微调值，最大为 120us；顺时针调节时，则减少微调值，最小为 -120us。注意当通道设置反向后，微调同步反向，即逆时针调节时减少微调值，顺时针调节时增大微调值。

功能设置：

顺时针或逆时针旋转通道对应的微调旋钮调节。过中位时，蜂鸣器响一声提示。

注：CH2 油门微调调整后，接收机须重新通电以识别新的油门中位，否则可能会出现倒车异常的现象。

D/R 比率设置

This function is used to adjust the rate of steering channel and throttle channel, so that the servo actions tend to be sensitive.

ST.D/R is used to adjust the steering channel rate. TH.D/R is used to adjust the throttle channel rate. Turning the knob anticlockwise will increase the value. Turning the knob clockwise will decrease the value. Smaller values indicate finer adjustment. The range is 0~100%.

Setup:

Turn the D/R switches corresponding to the channel clockwise or counterclockwise for D/R adjustment. The buzzer will have one beep when the position is reached to the center.

该功能用于调节方向通道和油门通道的比率，使舵机动作趋于灵敏。

ST. D/R 和 TH.D/R 旋钮分别对应方向通道和油门通道比率调节。逆时针调节数值增大，反之减小。数值越小调节越细腻，调节范围为 0~100%。

功能设置：顺时针或逆时针旋转通道对应的比率调节旋钮调节。过中位时，蜂鸣器响一声提示。

End Point Adjustment 能量设置

This function is used to adjust the end points of all channels, i.e. left and right angle of steering channel, forward and brake of throttle channel, and servo travel amount of CH3-CH11.

By default, it is used to set the steering channel end points. The end points setting of the others can be triggered by operating the control corresponding to this channel.

Steering Channel End Point Adjustment

Adjust the end points of steering channel (the control of steering channel is steering wheel).

Setup:

1. In the power-on state, press BIND twice, then the transmitter enters the end point setting mode. At this time, G.LED will work in two-flash-one-off mode repeatedly, and the buzzer will prompt with beeping twice cyclically.
2. Rotate the steering wheel to the appropriate travel point and hold it. Press BIND. The buzzer will prompt with beeping once cyclically.
3. Take the center of the steering wheel as the reference, reverse the rotation of the steering wheel to the appropriate travel point and hold it. Press BIND. The buzzer will be turned off at this time.
4. Press BIND for one second to save the setting and exit the end point setting mode. The buzzer will give a long beep, and the G.LED will be solid on. The end points setting of the steering channel is finished.

CH6 End Point Adjustment

Adjust the end points of CH6 .

Setup:

1. In the power-on state, press BIND twice, then the transmitter enters the end point setting mode. At this time, G.LED will work in two-flash-one-off mode repeatedly, and the buzzer will prompt with beeping twice cyclically.
2. Toggle CH6 Toggle Switch to one position. The buzzer will prompt with beeping three times cyclically.
3. Rotate the steering wheel to the appropriate travel point and hold it. Press BIND. The buzzer will prompt with beeping twice cyclically. The setting of this position is completed.
4. Toggle CH6 Toggle Switch to another position. Rotate the steering wheel to the appropriate travel point and hold it. Press BIND. The buzzer will prompt with beeping once cyclically. The setting of this position is finished.

5. Toggle CH6 Toggle Switch to the last position. Rotate the steering wheel to the appropriate travel point and hold it. Press BIND. The buzzer will be off at this time. The setting of this position is finished.

6. Press BIND for one second to save the setting and exit the end point setting mode. The buzzer will give a long beep, and the G.LED will be solid on. The end points setting of CH6 is finished.

Note: The end point values of at least two positions should be set.

Other Channels End Point Adjustment

Adjust the end points of the other channels.

Setup:

1. Refer to previous content, to put the transmitter into the end point setting mode.

2. Operate the control corresponding to the channel which you want to set.

3. Rotate the steering wheel to the appropriate travel point and hold it. Press BIND. The buzzer will prompt with beeping once cyclically.

4. Rotate the steering wheel to the appropriate travel point and hold it. Press BIND. The buzzer will be off at this time.

5. Press BIND for one second to save the setting and exit the end point setting mode. The buzzer will give a long beep, and the G.LED will be solid on. The end points setting of this channel is finished.

Notes:

1. If there is no response from the transmitter when a control is operated during the setup process, it means that the setup fails. In this case, you need to set it again.

2. Except the steering channel and throttle channel, you can operate the corresponding control to trigger the end points settings of other channels after completing the settings of one channel. For example, in the end points setting of CH3, you can press the CH4 button after the buzzer is turned off. At this time, the buzzer prompts with beeping twice cyclically. You can continue the end points setting of CH4. If you want to set the end points of the steering channel or throttle channel after setting other channels, the transmitter needs to re-enter the end point setting mode.

3. Throttle channel will maintain normal output during the end point setting of other channels.

该功能用于所有通道的行程大小，即方向通道左、右角度调整，油门通道前进、刹车以及通道 3 到通道 11 的行程量的调整。默认设置方向通道舵量。可通过操作其他通道所对应的控件触发此通道的舵量设置。

方向通道舵量调节

调节方向通道（控件为方向手轮）舵量。

功能设置：

1. 开机状态下，双击对码按键（BIND）使发射机进入舵量设置模式，此时 G.LED 指示灯为二闪一灭状态，蜂鸣器响 2 声循环提示；

2. 旋转手轮至合适的行程处并保持，按下对码按键（BIND），蜂鸣器变为响 1 声循环提示；

3. 以手轮中位点为基准，反向旋转手轮至合适的行程处并保持，按下对码按键（BIND），此时蜂鸣器关闭；

4. 长按对码按键（BIND）一秒保存设置并退出舵量设置模式，此时蜂鸣器长响一声提示，G.LED 指示灯变为常亮，方向通道舵量设置完成。

通道 6 舵量调节

调节通道 6 舵量。

功能设置：

1. 开机状态下，双击 BIND 键，使发射机进入舵量设置模式，此时 G.LED 指示灯为二闪一灭状态，蜂鸣器响 2 声循环提示；

2. 将 CH6 拨档开关拨至一处档位，蜂鸣器变为响 3 声循环提示；

3. 旋转方向手轮至合适的行程处并保持，按下对码按键（BIND），蜂鸣器变为响 2 声循环提示，此档位位置舵量设置完成；

4. 将 CH6 拨档开关拨至另一档位，旋转方向手轮至合适的行程处并保持，按下对码按键（BIND），蜂鸣器变为响 1 声循环提示，此档位位置舵量设置完成；

5. 将 CH6 拨档开关拨至最后一个档位，旋转方向手轮至合适的行程处并保持，按下对码按键（BIND），此时蜂鸣器关闭，此档位位置舵量设置完成；

6. 长按对码按键（BIND）一秒保存设置并退出舵量设置模式，此时蜂鸣器长响一声提示，G.LED 指示灯变为常亮。CH6 通道舵量设置完成。

注：舵量设置过程中至少要设置两个档位舵量数值。

其他通道舵量调节

调节其他通道行程量。

功能设置：

1. 参照前面内容，使发射机进入舵量设置模式；
2. 操作要设置的通道所对应的控件；
3. 旋转手轮至合适的行程处并保持，按下对码按键 (BIND)，蜂鸣器变为响 1 声循环提示；
4. 再一次旋转手轮至合适的行程处并保持，然后按下对码按键 (BIND)，此时蜂鸣器关闭；
5. 长按对码按键 (BIND) 一秒保存设置并退出舵量设置模式，此时蜂鸣器长响一声提示，G.LED 指示灯变为常亮。此通道舵量设完成。

注：

1. 若设置过程中按操作控件时发射机无响应则表示设置失败，请按功能设置重新设置。
2. 除方向通道和油门通道外，其他通道可在设置完上一通道舵量后，操作相应的控件触发其它通道的舵量设置。如当设置 CH3 通道舵量，在蜂鸣器关闭后，可按下 CH4 按键，此时蜂鸣器变为响 2 声循环提示，即可继续设置 CH4 通道舵量。若设置完其他通道后再设置方向通道或油门通道舵量，则须使发射机重新进入舵量设置模式后方可设置。
3. 在非油门通道舵量设置过程中，油门通道将保持正常输出

ESC Parameters Setting 电调参数设置

The function is adapted to a 2-in-1 receiver. The ESC parameters can be set by the 6-bit DIP Switch of the transmitter, that is, the DIP switch is located at different positions and the corresponding parameter values are different. There are three parameters can be set for the ESC, which are "Running Mode", "Battery Type" and "Drag Brake".

Running Mode

Forward/Reverse/Brake(F/R/B): This mode adopts "double click" reverse mode, that is, when the throttle trigger is pushed from neutral range to the reverse area for the first time, the motor is only braking and will not reverse; when the throttle trigger is moved back to the neutral range and pushed to the reverse area for the second time, it will reverse. This mode is applicable to general models.

Forward/Reverse(F/R): This mode adopts "one click" reverse mode, that is, when the throttle trigger is pushed from neutral range to the reverse area, the motor immediately generates reverse action, which is generally applied to rock crawler.

The switch marked 1 of 6-bit DIP switch is used to set the ESC running mode. The switch on the upper side indicates that the running mode is Forward/Reverse; and the switch on the lower side indicates that the running mode is Forward/Reverse/Brake.

Setup:

Toggle the switch 1 to the upper side, the buzzer will have one beep. Toggle the switch to the lower side, the buzzer will have two beeps.

Battery Type

There are LiPo and NiMH cells. It can be set according to the actual use.

The switch marked 2 of 6-bit DIP switch is used to set the battery type. The switch on the upper side indicates that the battery type is NiMH cells; and the switch on the lower side indicates that the battery type is LiPo.

Setup:

Toggle the switch 2 to the upper side, the buzzer will have one beep. Toggle the switch to the lower side, the buzzer will have two beeps.

Drag Brake

The drag brake means that when the throttle trigger moves from the forward or reverse area to neutral range, it will produce certain braking force to the motor, the larger the value is, the greater the drag brake force is. Select proper braking force according to the actual situation.

The CH11&Drag Brake knob is used to set the ESC drag brake force, which is adjusted counterclockwise to increase the value of the drag brake force, and vice versa. The setting range is from 0 to 100%.

Setup:

Turn the CH11&Drag Brake knob clockwise or counterclockwise for drag brake force adjustment. The buzzer will have one beep when the position is reached to the center.

System Functions 系统功能

此功能适配二合一接收机使用。可通过发射机的拨码开关设置电调参数，即拨码开关位于不同位置对应参数值不同。有三个参数项可以设置，分别是“运行模式”、“电池类型”、“拖刹力度”。

运行模式

正转 / 反转 / 刹车：此模式采用的是“双击式倒车”，即油门扳机在第一次从中点区域推至反向区域时，电机只是刹车，不会产生倒车动作；当油门扳机回到中点区域并第二次推至反向区域时，则产生倒车动作。此模式适用于一般车型。

正转 / 反转：此模式采用“单击式”倒车方式，即油门扳机从中点区域推至反向区域时，电机立即产生倒车动作，该模式一般用于攀爬车等特种车辆。

六位拨码开关第 1 位开关用于设置电调运转模式，开关在上侧，表示电机运行模式为正转 / 反转；开关在下侧，表示电机运行模式为正转 / 反转 / 刹车。

功能设置：

将拨码开关 1 拨至下侧，蜂鸣器响两声提示；将拨码开关 1 拨至上侧，蜂鸣器响一声提示。

电池类型

有锂电和镍氢两种选择，根据实际使用情况设置即可。

六位拨码开关第 2 位开关用于设置电调电池类型，开关在上侧，表示电池类型为镍氢；开关在下侧，表示电池类型为锂电。

功能设置：

将拨码开关 2 拨至下侧，蜂鸣器响两声提示；将拨码开关 1 拨至上侧，蜂鸣器响一声提示。

拖刹力度

拖刹是指当油门扳机从正向区域或反向区域转入中点区域内时，对电机产生一定的制动力，这样可以模拟有刷电机的碳刷对电机转子的阻力，适合减速入弯及攀爬车应用。

CH11&Drag Brake 旋钮用于设置电调拖刹力度，逆时针调节拖刹力度数值增大，反之减小。设置范围 0~100%。

功能设置：

顺时针或逆时针旋转 CH11&Drag Brake 旋钮调节。过中位时，蜂鸣器响一声提示。

Failsafe 失控保护

The failsafe function is used to protect the model and personnel when the receiver is out-of-control.

By default, it is not set, and the PWM interfaces will maintain the last output in case of out-of-control. The setting steps are as following.

Setup:

In the normal power-on state, set the control corresponding to the channel to be configured with failsafe to the preset position, meanwhile, press and hold the BIND button for 3 seconds to set the output value as the failsafe value. And the buzzer will give a long beep indicating that the setting is successful.

Notes:

1. When a 2-in-1 receiver has connected, the failsafe for CH2 is enabled by default, the ESC will enter the brake state when the receiver is out-of-control.
2. Restore to the default setting in case of re-binding.

此功能用于当接收机无法正常收到发射机的信号不受控制时，保护模型和操作人员的安全。

本发射机默认未设置时接收机通道保持最后输出。

功能设置：

开机正常状态下，操作需要设置失控保护的通道对应的控件至预设的位置，再长按对码按键（BIND）三秒，将当下输出的通道值设置为失控保护值。设置成功时，蜂鸣器长响一声提示。

注：

1. 若对码的是二合一电调接收机，失控后接收机自动进入刹车模式。
2. 重新对码时恢复默认设置。

Idle Alarm 闲置报警

The transmitter will go into idle alarm state when there is no operation over 10 minutes. When the transmitter is in idle alarm state, the G.LED will be in gradual light state, and the buzzer will prompt with beeping twice cyclically. Operate steering wheel or throttle trigger to cancel the idle alarm.

当发射机未操作时间大于 10 分钟时，即进入闲置报警状态。

在此状态下，发射机 G.LED 指示灯为呼吸灯状态且蜂鸣器响 3 声循环提示。闲置报警状态下，操作发射机的手轮或扳机可退出闲置报警状态。

Sleep Mode 休眠模式

When the transmitter has been in idle alarm state over 2 minutes, it will enter the sleep mode. In this mode, the G.LED will be in gradual light status, other indicators will be off, and the buzzer and RF will turn off. To exit the sleep mode, power off the transmitter and restart it.

当发射机处于闲置报警状态时间大于 2 分钟时，即进入休眠模式。

在此模式下，发射机 G.LED 指示灯为呼吸灯状态提示，其他指示灯灭，蜂鸣器关闭，RF 关闭。

须重启发射机才可退出休眠模式。

Transmitter Voltage Alarm 发射机电压报警

When the system detects a low voltage, it will give an alarm. Avoid accidents caused by long-term operation under low voltage.

When the voltage is detected below 4.2V/7.0V (AA battery/LiPo battery), there is an alarm due to low voltage. At this time, the G.LED will flash slowly, and the buzzer prompts with beeping once cyclically.

When the voltage is detected below 3.5V (ultra-low), the transmitting function is disabled. The G.LED will be in gradual light state.

当系统检测到低电压时，即发出报警。避免控制系统在低电压状态下长时间运行造成意外。

当检测到电压低于 4.2V/7.0V (AA 电池 /LiPo 电池)，即进入低电报警状态，此时 G.LED 指示灯慢闪状态，蜂鸣器响 1 声循环提示。

当检测到电压超低时（低于 3.5V 时），发射功能关闭，G.LED 指示灯为呼吸灯状态提示。

Data Reset 数据复位

This function is used to restore the end point value set to the default value.

Setup:

To restore to the default value, press the BIND and CH4 buttons of the transmitter at the same time, and power the transmitter on. At this time, the buzzer will give a long beep.

Note: This function is only applicable to resetting the end point value set to the default value.

此功能用于将设置的舵量数值恢复为默认值。

功能设置：

同时按住对码按键（BIND）和 CH4 按键后，并通电开机，即恢复成默认值，蜂鸣器长响一声提示。

注：此功能仅适用于复位舵量至默认值。

Transmitter Specifications 发射机规格

Product Model	FS-MG11-BS	产品型号	FS-MG11-BS
Compatible Receivers	FS-FMS-R11D-ESC-BS	适配接收机	FS-R11D-ESC-BS、FS-R11P-BS
Number of Channels	Model car	适配模型	遥控车
Compatible Models	11	通道个数	11
RF	2.4GHz ISM	无线频率	2.4GHz ISM
Maximum Power	<20dBm (e.i.r.p.) (EU)	发射功率	<20dBm (e.i.r.p.) (EU)
2.4GHz Protocol	2A-BS	无线标准	2A-BS
Distance	>150m(Ground Distance without Interference)	遥控距离	不低于 150m (空旷无干扰地面距离)
Resolution	4096	通道分辨率	4096
Input Power	AA*4 or 2S LiPo	输入电源	AA*4 或 2S 锂电池
Working Current	About 60mA/6V	工作电流	60mA 左右 /6V
Charging Interface	None (The Type-C USB port is only used for power supply.)	产品型号低电压报警	AA 电池: <4.2V; LiPo 电池: <7.0V
Antenna	Single Built-in Antenna	天线类型	内置单天线
Data Interface	None	充电接口	无 (USB 接口仅做供电使用)
Online Update	None	在线更新	无
Temperature Range	-10℃ ~ +60℃	温度范围	-10℃ ~ +60℃
Humidity Range	20% ~ 95%	湿度范围	20% ~ 95%
Color	Black	外观颜色	Black
Dimensions	135.7*189.5*82.7mm	外形尺寸	135.7*189.5*82.7mm
Weight	225g	机身重量	225g
Certifications	CE, FCC ID: 2A2UNMG1100	认证	CE, FCC ID: 2A2UNMG1100

Receiver Introduction 接收机介绍

FS-R11D-ESC-BS, in compliance with 2A-BS protocol, is a 2-in-1 CH11 receiver combining the Electronic Speed Control (ESC) and LED light set control board. It is equipped with a single external antenna, with the output of PWM signals and car light control signals. It can realize two-way transmission, with binding automatically upon power-up. Users can set ESC parameters at the transmitter side. FS-R11D-ESC-BS can be adapted to a variety of car models. FS-R11D-ESC-BS 采用 2A-BS 协议, 是一款带电调和 LED 灯组控制的二合一 11 通道接收机。它具有外置单天线, 可输出 PWM 信号和车灯控制信号, 能够实现双向传输, 通电自动对码, 可在发射机端设置电调的相关参数, 可适配多种车型使用。

Receiver Introduction 接收机介绍

Receiver Overview 接收机概览

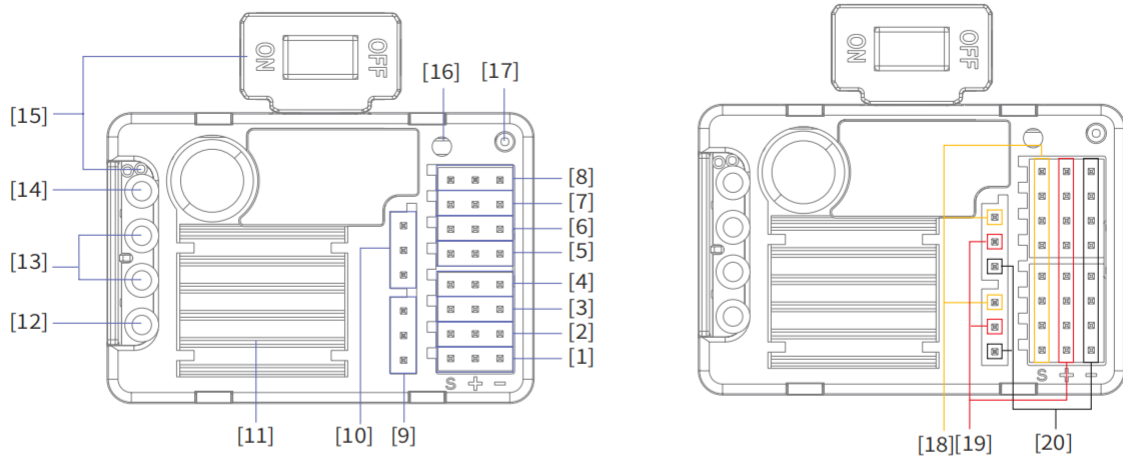

[1] CH1 Interface	[6] CH7	[11] Heatsink	[16] LED
[2] CH3 Interface	[7] CH8	[12] Motor Interface "-"	[17]Antenna
[3] CH4 Interface	[8] CH9	[13] Battery Interface	[18]S(CH/Car LightInterfaceSignalPin)
[4] LED Car Light Interface	[9] CH10	[14] Motor Interface "+"	[19] "+" (CH/Car LightInterfaceAnode)
[5] CH6 Interface	[10] CH11	[15] Power Switch	[20] "- " (CH/Car LightInterfaceCathode)
[1] CH1 通道接口	[6] CH7 通道接口	[11] 散热片	[16] LED 指示灯
[2] CH3 通道接口	[7] CH8 通道接口	[12] 马达接口 "-"	[17] 天线
[3] CH4 通道接口	[8] CH9 通道接口	[13] 电池接口	[18] S (通道 / 车灯接口信号端)
[4] LED 车灯接口	[9] CH10 通道接口	[14] 马达接口 "+"	[19] "+" (通道 / 车灯接口正极)
[5] CH6 通道接口	[10] CH11 通道接口	[15] 电源开关	[20] "- "(通道 / 车灯接口负极)

Notes:

- All channel interfaces are 2.54mm*3 Pin standard pins, and the battery interface is XT60 male interface, and the spec of motor interface is a 4.0 mm bullet female connector.
- The LED car light interface is used to connect FS-DB01 car light drive board.

注:

- 所有通道接口均采用标准 2.54mm*3 Pin 排针; 电池接口采用 XT60 公头接口; 马达接口采用 4.0 mm子弹头母型接口。
- LED 车灯接口用于连接 FS-DB01 车灯驱动板。

Protection 保护功能

This receiver has low/high voltage protection function.

- Low Voltage Protection: When the voltage is detected to be low, CH2 has no output and all the car lights flash slowly.
- High Voltage Protection: When the voltage is detected to be high, all channels will not output. All all the car lights flash fast.

The ESC has overheating protection function.

- Overheating Protection: When the internal temperature of the ESC is detected to be too high, CH2 has no output and all the car lights flash fast. When the temperature is normal, the channel resumes output.

本接收机具有电池电压过低和过高保护功能。

- 电压过低保护: 当检测到电池电压过低时, CH2 通道无输出, 所有车灯慢闪提示。
- 电压过高保护: 当电池电压过高时, 所有通道无输出, 所有车灯快闪提示。

本接收机电调具有过热保护功能。

- 过热保护: 当检测到电调内部温度过高时, CH2 通道无输出, 所有车灯快闪提示; 当温度正常后, 通道恢复输出。

ESC Function Instruction 电调功能说明

This receiver ESC function supports the settings of battery type, drag brake and running mode (forward/reverse, forward/reverse/brake) at the transmitter side. See the FS-MG11-BS transmitter manual for details.

After the motor is connected, the receiver automatically recognizes the throttle neutral every time it is powered on.

•When the connected battery type is lithium-ion, such as 2S LiPo, the motor fast beeps twice (3 beeps represent 3S LiPo).

•If throttle neutral is not recognized, the motor will continue to beep quickly. There is no power output from the motor at this time.

Notes:

1.The ESC function is available for running until the self-inspection is completed (it takes about 3 seconds). Otherwise, it may not be able to operate normally.

2. If you find that the motor steering is not correct during operation, you can set the throttle channel in reverse at the transmitter side.

3.Normally, you must power on the transmitter and then receiver, and power off the receiver and then transmitter.

本接收机电调功能支持在发射机端设置电池类型设置、拖刹力度设置和运行模式（正转 / 反转、正转 / 反转 / 刹车）的设置，详见 FS-MG11-BS 发射机说明书相关章节。

马达连接后，接收机每次开机即自动识别油门中位位置。

•当连接的电池类型为锂电时，如使用 2S 锂电，则马达快响两声（3 声代表 3S 锂电）提示；

•当油门中位识别通过后，马达长响一声提示。

若未识别油门中位，马达持续快响提示，此时马达无动力输出。

注：

1.电调功能必须等到开机自检完成后方可运行（大约 3 秒），否则可能无法正常动作；

2. 若运行时发现电机转向不对，则可在发射机端将油门通道反向设置即可；

3.为了一切正常，请养成先开发射机再接收机通电以及先接收机断电再关闭发射机的习惯。

Failsafe 失控保护

The failsafe function is used to protect the model and personnel when the receiver is out-of-control.

• The CH2 (ESC) enters the braking state in case of out-of-control, for the other channel, the failsafe can be set at the transmitter side. By default, it is not set, and the receiver will maintain the last output at the time.

• If the FS-DB01 car light drive board is connected to the LED car light interface, and the left and right turn signal lights are also connected, when the receiver is out-of-control, then the left and right turn signal lights flash fast for prompt.

此功能用于当接收机无法正常收到发射机的信号不受控制时，保护模型和操作人员的安全。

• 接收机 CH2 通道（电调），失控后进入刹车模式，其他通道可在发射机端进行相关设置，默认未设置，默认未设置时接收机通道保持最后输出；

• 失控后，若 LED 车灯接口连接了 FS-DB01 灯板，且连接了左转灯和右转灯，则左、右车灯同步快闪提示。

Car Light Control 车灯控制

The following is the output function of the built-in light control in the receiver. There may be differences in the factory settings for each RC model vehicle.

This receiver features 6 sets of lights: left turn signal light, right turn signal light, daytime running light, headlight, brake light and reverse light.

And these 6 sets of lights are connected to this receiver through the FS-DB01 car light driver board.

The state of all the car lights is controlled by the corresponding controls of the FS-MG11-BS transmitter. The left and right turn signal lights are controlled by steering wheel. The daytime running lights and headlights are controlled by CH5 knob. The brake and reverse lights are controlled by throttle trigger. Details are as follows:

以下为接收器内置灯控的输出功能，每款模型车出厂设置会有差异。

本接收机支持 6 组车灯：左转灯、右转灯、日行灯、前大灯、刹车灯和倒车灯（此 6 组车灯通过 FS-DB01 车灯驱动板与本接收机建立连接）。

车灯状态由 FS-MG11-BS 发射机的相应控件控制。左、右转向灯亮灭状态由手轮控制；日行灯和前大灯亮灭状态由 CH5 旋钮控制；刹车灯和倒车灯亮灭状态由扳机控制。具体有如下所述：

Receiver Introduction 接收机介绍

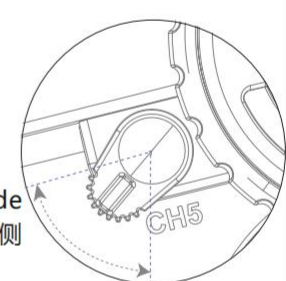
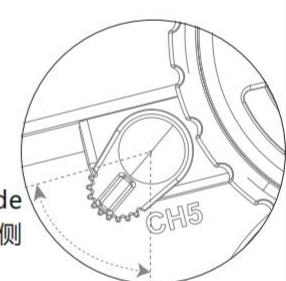
Car Lights 车灯	Car Light State 车灯状态	Control State 控制状态	Control 控件	Trigger Condition 触发条件	Notes 备注
Left Turn Signal Light 左转向灯	Slow Flash 慢闪	Turn Left 左转	Steering Wheel 手轮	Turn the steering wheel counter clockwise. 逆时针打手轮	If you set the steering channel in reverse, the trigger condition for left and right turn signal lights will not be affected. 方向通道设置反向后对左、右转向灯无影响。
Right Turn Signal Light 右转向灯	Slow Flash 慢闪	Turn Right 右转	Steering Wheel 手轮	Turn the steering wheel clockwise. 顺时针打手轮	
Daytime Running Light 日行灯	OFF 常灭	/	CH5 Knob CH5 旋钮	CH5 Knob is located at the left side. CH5 旋钮位于左侧	
	Solid ON 常亮			CH5 Knob is located in the middle. CH5 旋钮位于中间	
	Solid ON 常亮			CH5 Knob is located at the right side CH5 旋钮位于右侧	
Headlight 前大灯	OFF 常灭	/	CH5 Knob CH5 旋钮	Same as the DRL above 触发条件同日行灯	
	OFF 常灭				
	Solid ON 常亮				
Brake Light 刹车灯	Solid ON 常亮	Brake 刹车	Trigger 扳机	Push the throttle trigger forward. 前推扳机	When the running mode of ESC is set to Forward/Reverse mode (no brake), the Brake- Light will not on when pushing the throttle trigger forward. 当电调运行模式设置为正转 / 反转模式时 (无刹车), 前推 扳机刹车灯不亮。
Reverse Lights 倒车灯	Solid ON 常亮	Back up 倒车	Trigger 扳机	Push the throttle trigger forward. 前推扳机	/

Notes:

1. After the receiver is turned on, all the lights will be on for one second and then go out.
2. The steering CH1 channel and throttle CH2 channel are capable of automatic neutral identifying, after the trim is adjusted, the receiver should be powered to recognize the neutral positions of these two channels automatically.

注:

1. 接收机开机后, 所有车灯常亮一秒后灭;
2. 方向通道 CH1 和油门通道 CH2 具有自动识别中位的功能, 当调过微调后, 需重新给接收机上电以完成中位自动识别。

Receiver Specifications 接收机规格

Product Model	FS-R11D-ESC-BS	产品型号	FS-R11D-ESC-BS
Adaptive Transmitters	FS-MG11-BS	适配发射机	FS-MG11-BS
Number of Channels	Model car	适配模型	遥控车
Compatible Models	11	通道个数	11
Number of Car Light Interfaces	6 (LED car light interface connects to FS-DB01)	车灯组数	6 (LED 车灯接口连接 FS-DB01 车灯驱动板)
Compatible Models	2.4GHz ISM	无线频率	2.4GHz ISM
Maximum Power	<20dBm (e.i.r.p.) (EU)	发射功率	<20dBm (e.i.r.p.) (EU)
2.4GHz Protocol	2A-BS	无线协议	2A-BS
Antenna	Single External Antenna (Coaxial Antenna)	天线类型	外置单天线 (同轴天线)
Input Power	LiPo (2~3S) /NiMH(5~9Cell)	输入电源	LiPo (2~3S) /NiMH(5~9Cell)
BEC Output	6V/5A	BEC 输出	6V/5A
Continuous / Peak Current	60A/240A	持续 / 峰值电流	60A/240A
Motor Type	Brushed Motor	支持电机类型	有刷电机
Applicable Motors	370,390,540 or 550 Brushed Motor	适配电机	370、390、540 或 550 有刷电机
Data Output	PWM	数据输出	PWM
Resolution	4096	通道分辨率	4096
Temperature Range	-10℃ ~ +60℃	温度范围	-10℃ ~ +60℃
Humidity Range	20% ~ 95%	湿度范围	20% ~ 95%
Distance	>150m(Ground Distance without Interference)	遥控距离	不低于 150m (空旷无干扰地面距离)
WaterProof	PPX7	防水等级	PPX7
Dimensions	44.0mm*30.0mm*16.7mm	外形尺寸	44.0mm*30.0mm*16.7mm
Weight	45g	机身重量	45g
Certifications	CE, FCC ID: 2A2UNR11D00	认证	CE, FCC ID: 2A2UNR11D00

Car Light Drive Board 车灯驱动板

FS-DB01 is a car light driver board for the FS-R11D-ESC-BS receiver. This light board has 6 sets of car light interfaces, and each set of car light can be independently controlled. The waterproof rate is PPX4.

FS-DB01 是一款适配 FS-R11D-ESC-BS 接收机使用的车灯驱动板。本灯板具有 6 组车灯接口，且各组车灯可独立控制，防水性能达 PPX4 级。

Car Light Drive Board Overview 车灯驱动板概览

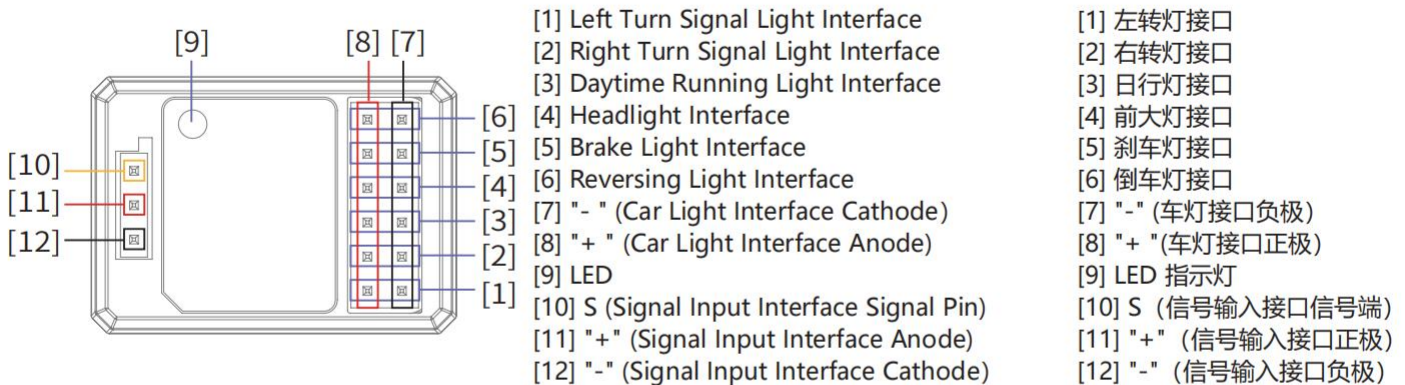

Notes:

1. All car light interfaces are 2.54mm*2 Pin standard pins, and the signal input interface is 2.54mm*3 Pin standard pins.
2. The signal input interface is used to connect FS-R11D-ESC-BS receiver.

注:

1. 所有车灯接口均采用标准 2.54mm*2 Pin 排针，信号输入接口采用标准 2.54mm*3 Pin 排针；
2. 信号输入接口用于连接 FS-R11D-ESC-BS 接收机。

Functions 功能相关

Connection between car light drive board and receiver

Connect the car light drive board to the LED interface of the FS-R11D-ESC-BS receiver through the signal input interface.

LED Status

- When the LED is solid on, the car light driver board is in normal working state.
- When the LED flashes slowly, the car light driver board does not receive valid signals.

车灯驱动板与接收机连接

将车灯驱动板通过信号输入接口与 FS-R11D-ESC-BS 接收机的 LED 灯接口相连接。

LED 状态说明

- LED 指示灯常亮，车灯驱动板为正常工作状态
- LED 指示灯慢闪，车灯驱动板未收到有效信号

Car Light Drive Board 车灯驱动板

Car Light Drive Board Specifications 车灯驱动板信息

Product Model	FS-DB01	产品型号	FS-DB01
Adaptive Receivers	FS-R11D-ESC-BS	适配接收机	FS-R11D-ESC-BS
Adaptive Model	RC Car	适配模型	RC Car
Number of Car Light Interfaces	6	车灯组数	6
Input Power	3.5~8.4V/DC	输入电源	3.5~8.4V/DC
Working Current	20mA/5V	工作电流	20mA/5V
Temperature Range	-10℃ ~ +60℃	温度范围	-10℃ ~ +60℃
Humidity Range	20% ~ 95%	湿度范围	20% ~ 95%
WaterProof	PPX4	防水等级	PPX4
Dimensions	27.0mm*19.0mm*13.5mm	外形尺寸	27.0mm*19.0mm*13.5mm
Weight	4.2g	机身重量	4.2g
Certifications	CE, FCC	认证	CE, FCC

Attention 注意事项

- Make sure the product is installed and calibrated correctly, failure to do so may result in serious injury.
- Please carefully check each power device and car frame instructions to ensure the power matching is reasonable before use. Avoid damaging power system due to incorrect matching.
- Do not let the external temperature of the system exceed 90℃ /194 ℉ , because high temperature will damage the power system.
- Make sure the receiver's battery is disconnected before turning off the transmitter, failure to do so can result out of control. Unreasonable setting of the Failsafe may cause accidents.
- After use, remember to disconnect the battery and the ESC. If the battery isn't disconnected, the ESC will consume electric energy all the time even if it is off. It will discharge completely if connect the battery for a long time, thus resulting in the failure of the battery or the ESC. We are not responsible for any damage caused by this!
- Make sure the receiver is mounted away from motors or any device that emits excessive electrical noise.
- Keep the receiver's antenna at least 1cm away from conductive materials such as carbon or metal.
- Do not power on the receiver during the setup process to prevent loss of control.
- If the throttle trim is changed on the transmitter side, the receiver needs to be re-powered to recognize the new throttle neutral. Otherwise, an exception may occur during vehicle reversing
- 使用前必须确保本产品与模型安装正确，否则可能导致模型发生严重损坏。
- 请查看各动力设备以及车架说明书，确保动力搭配合理，避免因错误的搭配导致动力系统损坏。
- 勿使系统的外部温度超过 90℃ /194 ℉，高温将会毁坏动力系统。
- 关闭时，请务必先关闭接收机电源，然后关闭发射机。如果关闭发射机电源时接收机仍然在工作，将导致遥控设备失控。失控保护设置不合理可能引起事故。
- 使用完毕后，若长时间不玩车，切记断开电池与电调的连接。如电池未断开，即使电调开关处于关闭状态，电调也会一直消耗电能（只是非常小），长时间连接电池最终会被过放，进而导致电池或电调出现故障。我们不对因此而造成的任何损害负责！
- 确保接收机安装在远离电机或电子噪声过多的区域。
- 接收机天线需远离导电材料，例如金属棒和碳物质。为了避免影响正常工作，请确保接收机天线和导电材料之间至少有 1 厘米以上的距离。
- 准备过程中，请勿连接接收机电源，避免造成不必要的损失。
- 若在发射机端调整油门通道微调后，接收机须重新通电以识别新的油门通道中位，否则可能会出现倒车异常的现象。

Troubleshooting 故障快速处理

Troubles 故障现象	Possible Causes 可能原因	Solutions 解决方法
The motor cannot start and the LED is not on after power-on. 上电后，指示灯不亮，电机无法启动	1. The ESC has no working voltage. 2. The switch of ESC or ESC itself is damaged. 1. 电调没有得到工作电压；2. 接收机开关或电调损坏。	1. Check whether there is any connection problem between the battery and ESC and whether there is faulty welding of the relevant plug.2. Return to factory for inspection and treatment. 1. 检查电池与电调有无连接问题以及相关插头是否有虚焊情况；2. 返厂检测处理。
The motor cannot start after power-on. 上电后，电机无法启动	The throttle channel neutral of the transmitter is shift or changed. 发射机油门通道的中点偏移或改变。	1. Ensure that the transmitter trigger is in its natural state when re-powering the transmitter.2. Adjust the throttle channel of the transmitter by trim function to match the existing neutral position of ESC. 1. 重新上电时，确保发射机扳机处于自然状态；2. 调节发射机油门通道微调使之匹配电调现有中立点。
When forward the car by the transmitter, it reverse. 发射机做前进操作，车子反而倒退	1. It may cause by the connection sequence between output line of ESC and motor line.2.The throttle direction of transmitter is wrongly set. 1. 电调输出线和电机线的连接线序错误；2. 发射机油门方向设置错误。	1. Exchange the position of two lines of motor.2. Set throttle direction of transmitter to the opposite direction. 1. 将电机的两条线互换位置即可；2. 将发射机油门方向设置为相反方向。
When forward the car by the transmitter, it reverse. 电机转动过程中，突然停转	1. It may cause by the connection sequence between output line of ESC and motor line.2.The throttle direction of transmitter is wrongly set. 1. 油门信号丢失；2. 电调进入电池低压保护或过热保护。	1. Exchange the position of two lines of motor.2. Set throttle direction of transmitter to the opposite direction. 1. 检查发射机和接收机；2. 请检查电池电压以及电调温度。
When the motor starts, it accelerates rapidly, and the motor is stuck or stops. 电机启动时急加速，电机有卡住或停顿的现象	1. Battery discharge capacity is insufficient.2. The rotation speed of motor is too fast, the gear ratio is not reasonable. 1. 电池放电能力不够；2. 电机转速过高，齿轮比搭配不合适。	1. Replace battery with strong discharge capacity.2. Replace low speed motor, or increase the reduction ratio. 1. 更换放电能力强的电池；2. 更换低速电机，或将减速比提高。

Vehicle Setup 车辆设置

Battery Precautions 电池注意事项

- Never charge a lithium polymer battery with a charger designed for NiCd, NiMH, or any other type of battery chemistry.
- Use ONLY charger designed for LiPo battery.
- Do not leave LiPo battery unattended during charging.
- Do not overcharge the battery.
- Always charge LiPo batteries on non-flammable, heat-resistant surfaces.
- Always use a LiPo-safe bag or container while charging.
- Do not allow LiPo cells to overheat at any time. Cells which reach greater than 140 Fahrenheit(60℃) will usually become damaged and will catch fire.
- Do not charge the LiPo pack while it is still in the model.

- Never charge or store battery packs in a vehicle.
 - Do not discharge LiPo, doing so will damage the battery.
 - Do not expose LiPo cell to water or moisture at any time.
 - Do not store battery near open flame or heater.
 - Do not assemble LiPo cells or pre-assembled packs together with other LiPo cells or packs.
 - Always store LiPo battery in a secure location away from children.
 - Always remove the LiPo battery if model is involved in any kind of crash.
 - Carefully inspect the battery and connectors for even the smallest damage.
 - CAUTION: Cells may become hot after usage. • Allow the pack to cool to room temperature prior to recharging.
 - Do not allow the electrolyte to get into eyes or on skin. Wash affected areas immediately if they come into contact with electrolyte.
 - Do not alter or modify connectors or wires of a LiPo battery pack.
 - Always inspect the condition of the battery before charging and operating.
 - Do not short circuit the LiPo battery.
 - Do not have contact with a leaky/damaged battery directly.
 - Do not charge battery out of recommended temperature range(0°C-45°C)
- 不要使用NiCd、NiMH或任何其他类型的充电器给LiPO锂聚合物电池充电。
 - 请使用LiPO锂聚合物的专用充电器给LiPO锂聚合物电池充电。
 - 请勿在无人看管的情况下充电。
 - 电池请勿过充。
 - 请勿将电池放置在易燃、不耐热的表面上充电。
 - 总是使用安全袋或安全容器给电池充电。
 - 保证电池在任何时候都不过热。电池温度超过140华氏度（60°C）则易造成损坏，甚至引发火灾。
 - 请勿将电池长期置于模型产品内，更勿在模型产品内直接充电。
 - 请勿给电池放电，以免损坏电池。
 - 任何时候请勿将电池暴露在水或湿气之中。
 - 请勿在明火或加热器附近储放电池。
 - 请勿与其他未组装或预组装的电池混用。
 - 需将电池存放在远离儿童的安全位置。
 - 模型如出现任何碰撞，需立刻拆除电池。即使出现微小的损坏，也需仔细检查电池和连接器。
 - 注意：使用后电池可能会发热，需让电池冷却到室温后再进行充电。
 - 请勿让电解液接触眼睛或皮肤。如电解液不慎接触到身体的任何部位，请立即进行清洗。
 - 请勿替换或修改电池组的连接器或电线。
 - 在进行充电或其他任何操作之前需检查电池的状况。
 - 请勿造成电池短路。
 - 请勿直接接触已泄漏或已损坏的电池。
 - 请勿超出建议温度范围充电电池（0度-45度）。

Connecting the battery 连接电池

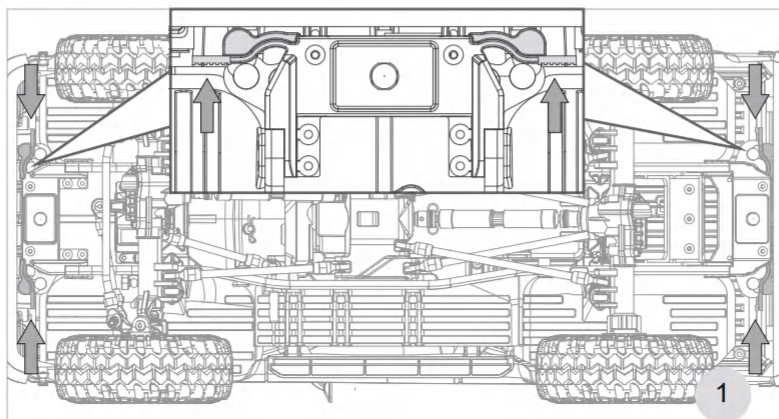

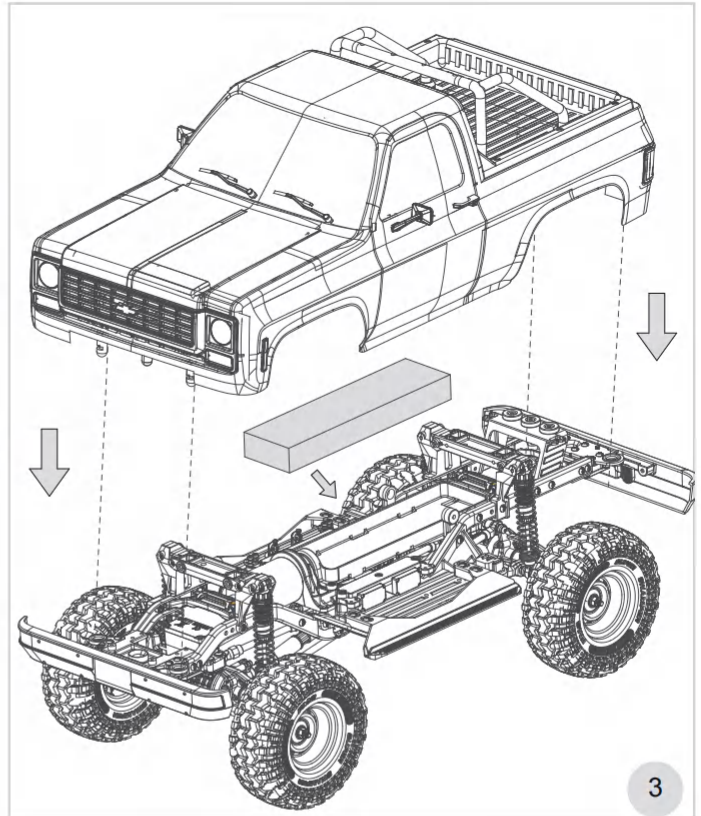
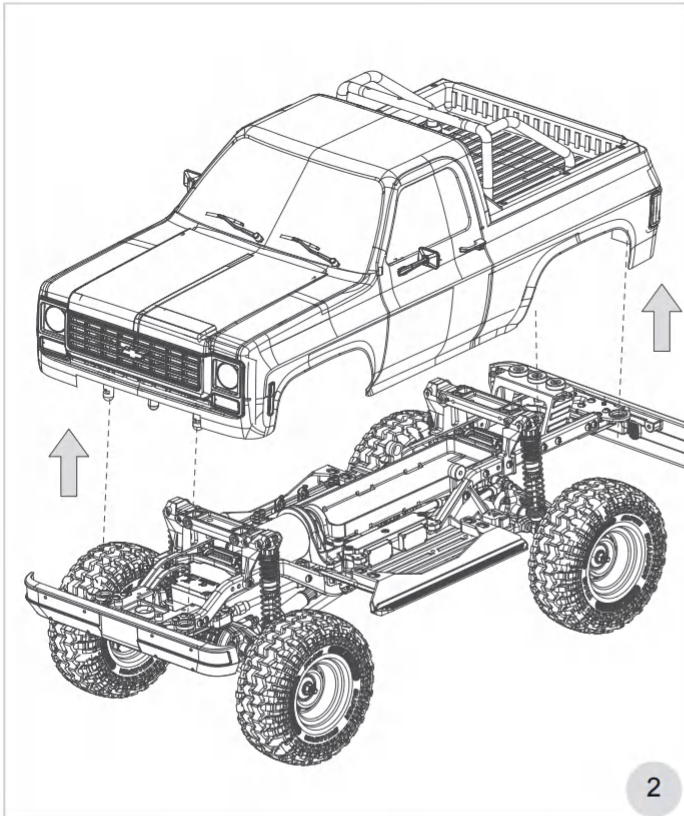

1. Gently push the front latches forward and the rear latches backward to separate the car shell from the chassis.
2. As shown in the diagram, place the battery inside the battery compartment and secure it in place using the included battery strap. Connect the battery to the RX/ESC 2-in-1 unit (batteries sold separately, recommended batteries are advised).
3. Align the front and rear pillars of the car shell with the corresponding snap joints on the chassis, then push them in to reattach the car shell onto the chassis.

Battery compartment size: 140 * 47 * 30mm

The battery plug :XT60 Male

1. 将车头的扣位轻轻向前推，车尾的扣位轻轻向后推，以分离车壳与车底盘。
2. 如图所示，将电池放入电池仓内，并使用附带电池轧带固定到位，连接电池至电调/接收二合一组件（电池需另购，建议使用推荐电池）。
3. 将车壳的前后柱体对准并推入车底盘的前后扣位，以重新安装车壳至底盘。

电池仓尺寸：140 * 47 * 30mm

电池插头：XT60 公头

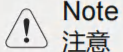

Note
注意

1. Please remove the battery immediately after use (allow time for the battery to cool down) and do not store the battery inside the model product for an extended period.
 2. Do not open, disassemble, or attempt to repair the battery.
 3. The battery needs to be disconnected from vehicle before it can be charged
 4. Do not charge battery in vehicle.
- 1、请在使用后立即取出电池（需等待电池降温），不可将电池长时间存放在模型产品内。
 - 2、不要打开、拆解或试图维修电池。
 - 3、在给电池充电之前，需要先断开电池与车辆的连接。
 - 4、请勿在车内给电池充电。

Spare Parts List

配件列表

C3273	Car body assembly painted black	车壳总成黑色
C3272	Car body assembly painted orange	车壳总成橙色
C3197	Car body assembly painted brown	车壳总成棕色
C3198	Clear car body kit	透明车壳散件
C3205	Transmission gear box assembly	驱动牙箱总成
C3206	Transmission gear box housing	驱动牙箱壳胶件
C3207	Motor mount	电机码件
C3208	Slipper sheet	限滑片
C3209	550 high performance motor	550高效能电机
C3210	12T pinion gear	12T 电机齿
C3211	Gear set for transmission gear box	变速箱齿轮
C3212	Transmission gear shift	变速箱轴
C3213	Clutch engage switcher	离合器接合件
C3214	Front axle assembly	前桥总成
C3215	Rear axle assembly	后桥总成
C3216	Wheel assembly 1pair	车轮套装总成 一对
C3217	Tires 5.3x2.2'	车轮胎 5.3x2.2' 一对
C3218	Oil shock absorbers assembly 1pair	避震器总成一对
C3219	Transmission box shaft assembly	传动轴总成
C3220	Metal frame rail set	金属大梁
C3221	Shock absorbers tower set	避震架
C3222	Girder mount set	大梁连接件
C3223	Battery box set	电池箱零件
C3224	Transmission box mount	变速箱码件
C3225	Car body mount set	车壳固定件
C3226	Chassis side plates	踏板
C3227	Front rod set	前拉杆散件
C3228	Rear rod set	后拉杆散件
C3230	Functional servo mount	功能舵机伺服码件
C3231	Universal driveshaft set front	前轮传动轴组
C3232	Front axle housing	前桥胶件
C3233	Rear axle housing	后桥胶件
C3234	Steering servo mount	转向舵机码件
C3235	Steering linkage and panhard bar	转向拉杆及扯推杆
C3236	Portal axle housing	门桥胶件
C3237	Rear wheel driveshaft 1pair	后轮轴一对
C3238	Portal axle shift and gear	门桥轴及齿轮
C3239	Differential locker	差速锁总成
C3240	Drive gear	驱动齿
C3241	Differential gear and pins	差速齿及轴针
C3242	17mm hex set with set screw pins	17mm 六内接合件及机米螺丝
C3243	Differenyial locker torsional spring and arm set (F/R)	前/后锁差扭簧及摇臂
C3244	Pivot balls	铝球头

Spare Parts List 配件列表

C3245	Bushing set	套筒介子
C3246	Steering horn arm	转向舵机臂
C3247	25KG metal gear servo waterproof	25KG金属齿舵机
C3248	13G metal gear servo waterproof	13G金属齿舵机
C3249	13G servo saver set with horn arm	13G舵机护器及舵机臂
C3250	Front bumper set	前防撞
C3251	Rear bumper set	后防撞
C3252	Drag brake rod and gearshift rod	拖刹拉杆及换挡拉杆
C3253	Hopper cover with window (black)	车斗盖及窗黑色
C3254	Hopper cover with window (white)	车斗盖及窗白色
C3255	Windows	车窗
C3256	Roll bar	防滚架
C3257	Windshield wiper	雨刷
C3258	Door handle and rearview mirror	门把及后视镜
C3259	Front body mount	前车壳码件
C3260	Rear body mount	后车壳码件
C3261	Front and rear light cup with lens	前后灯杯及灯片
C3262	Exhaustion plate	面罩
C3370	MG11 + R11D transmitter receiver /ESC set	MG11 + R11D 发射器/电调接收器
C3371	MG11 transmitter	MG11 发射器
C3372	R11D receiver/ESC	R11D 电调接收器
C3266	Bearing set	轴承
C3267	Wire buckle	线扣
C3268	M4 screw nut	M4防滑螺母
C3269	Logo and license plate	徽标及车牌
C3270	Steel wire	钢丝
C3271	Exhaustion plate style A	面罩A款套装
C3200	Front bumper rhino style	前防撞犀牛角款
C3194	Coupler A	金属拖车钩 A
C3347	Coupler B	金属拖车钩 B
C3195	Metal front bumper set	金属前防撞
C3342	Metal rear bumper set	金属后防撞
C3196	Window anti-riot net	车窗防护
C3339	Light control connection set	灯控接驳套件
C3340	Light control system	灯控器



C3218

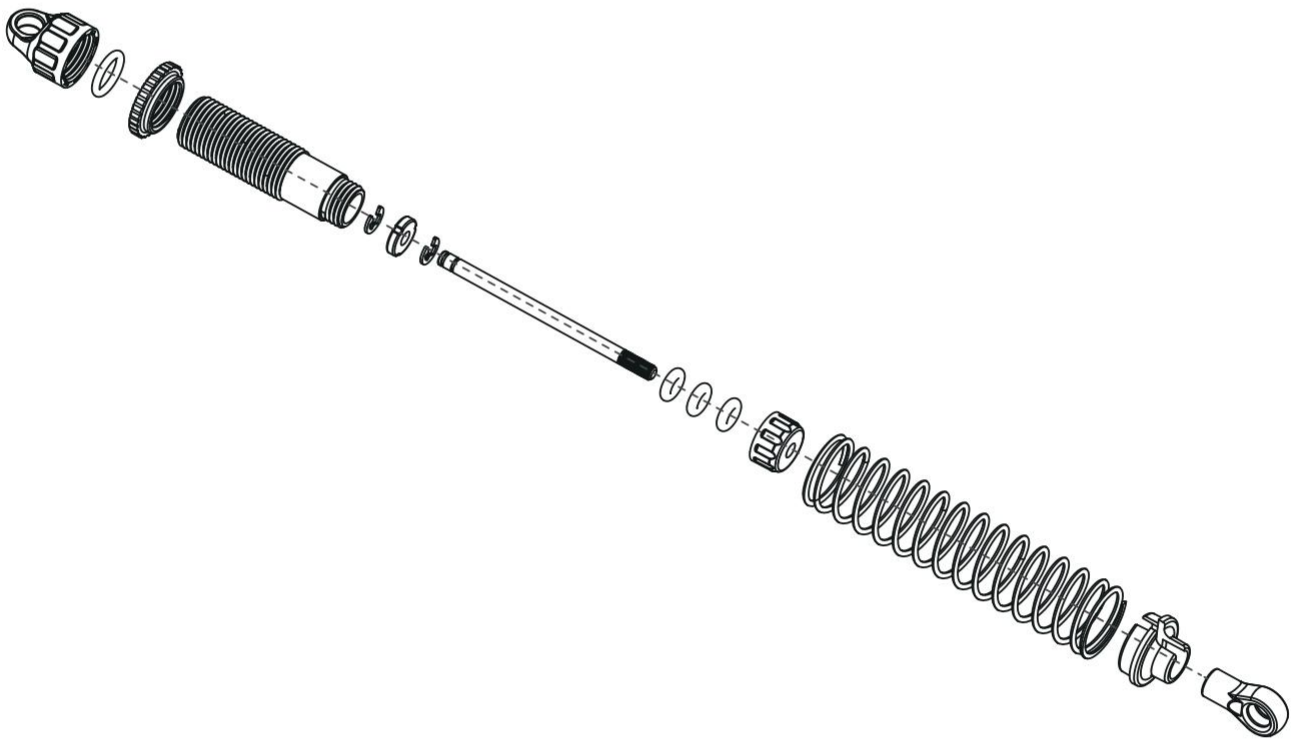

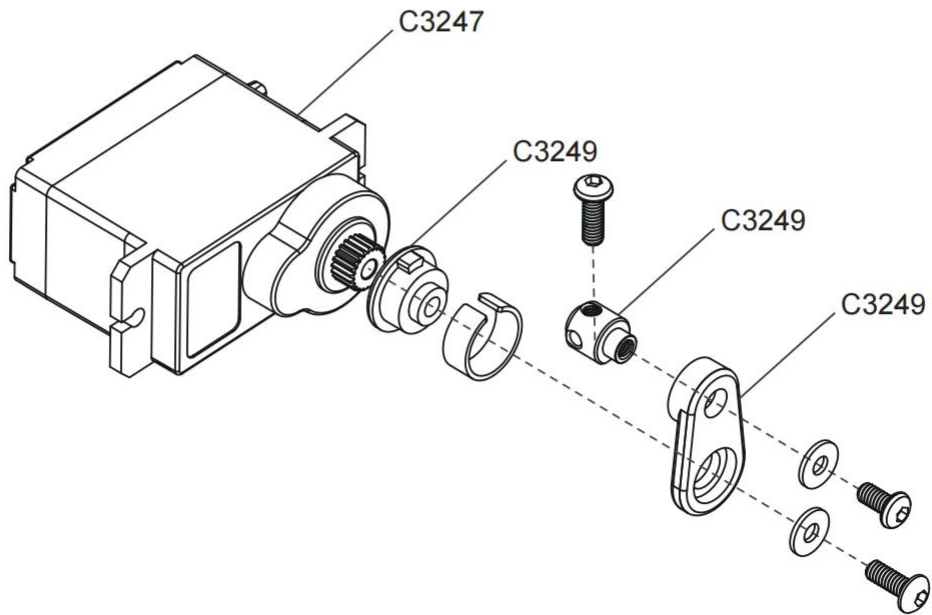
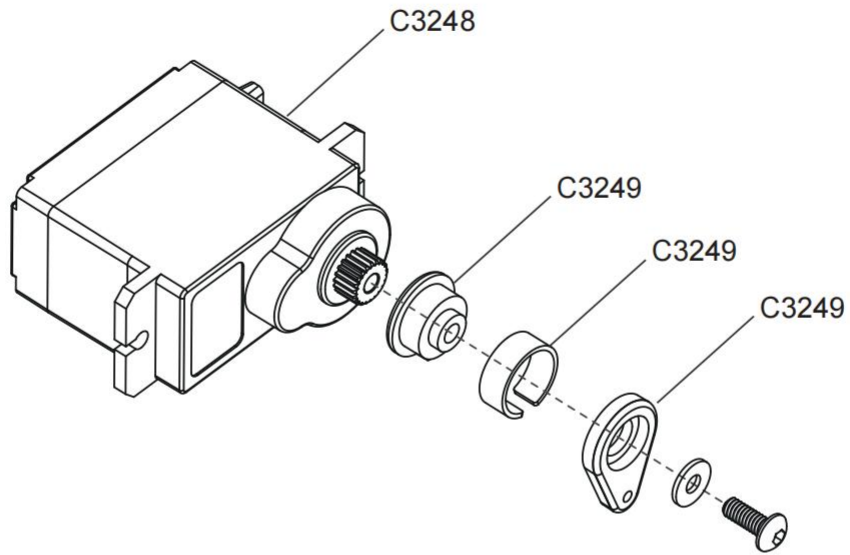

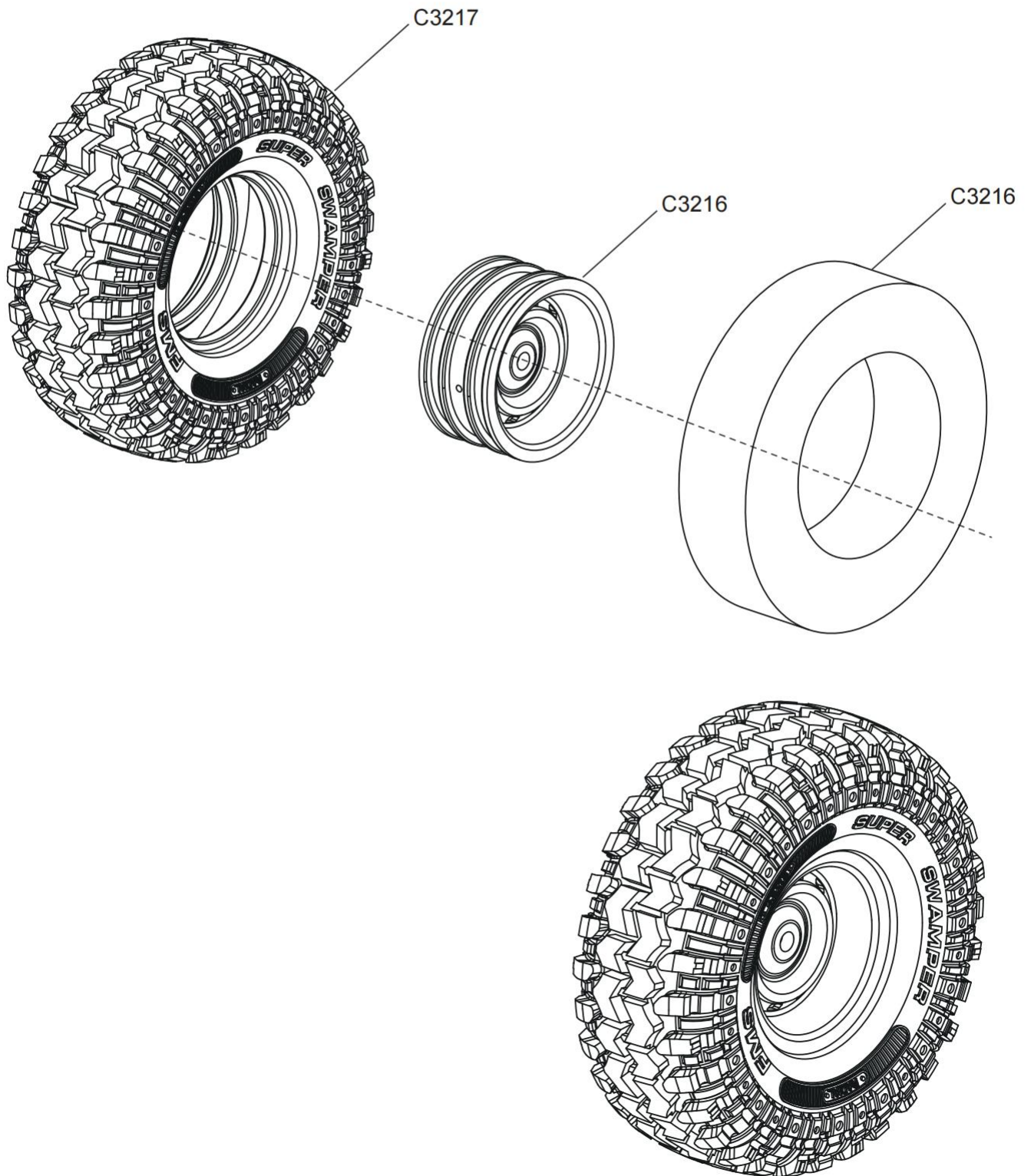

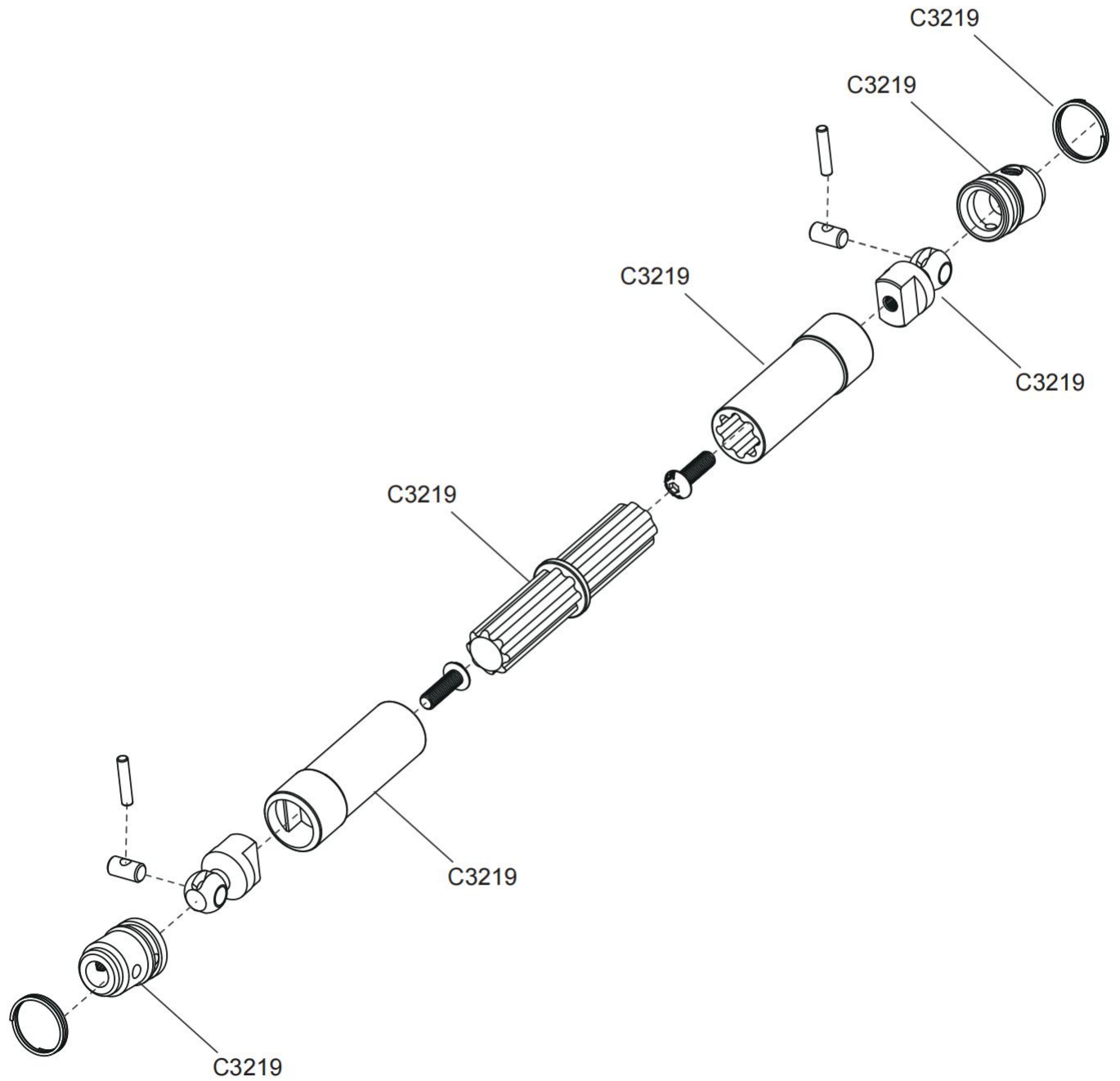

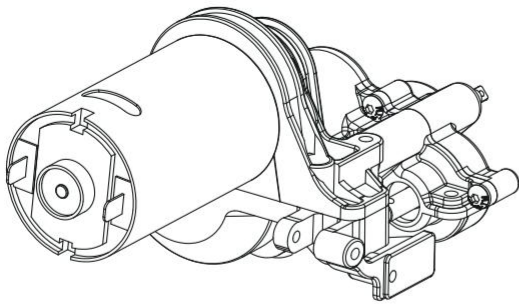

C3205

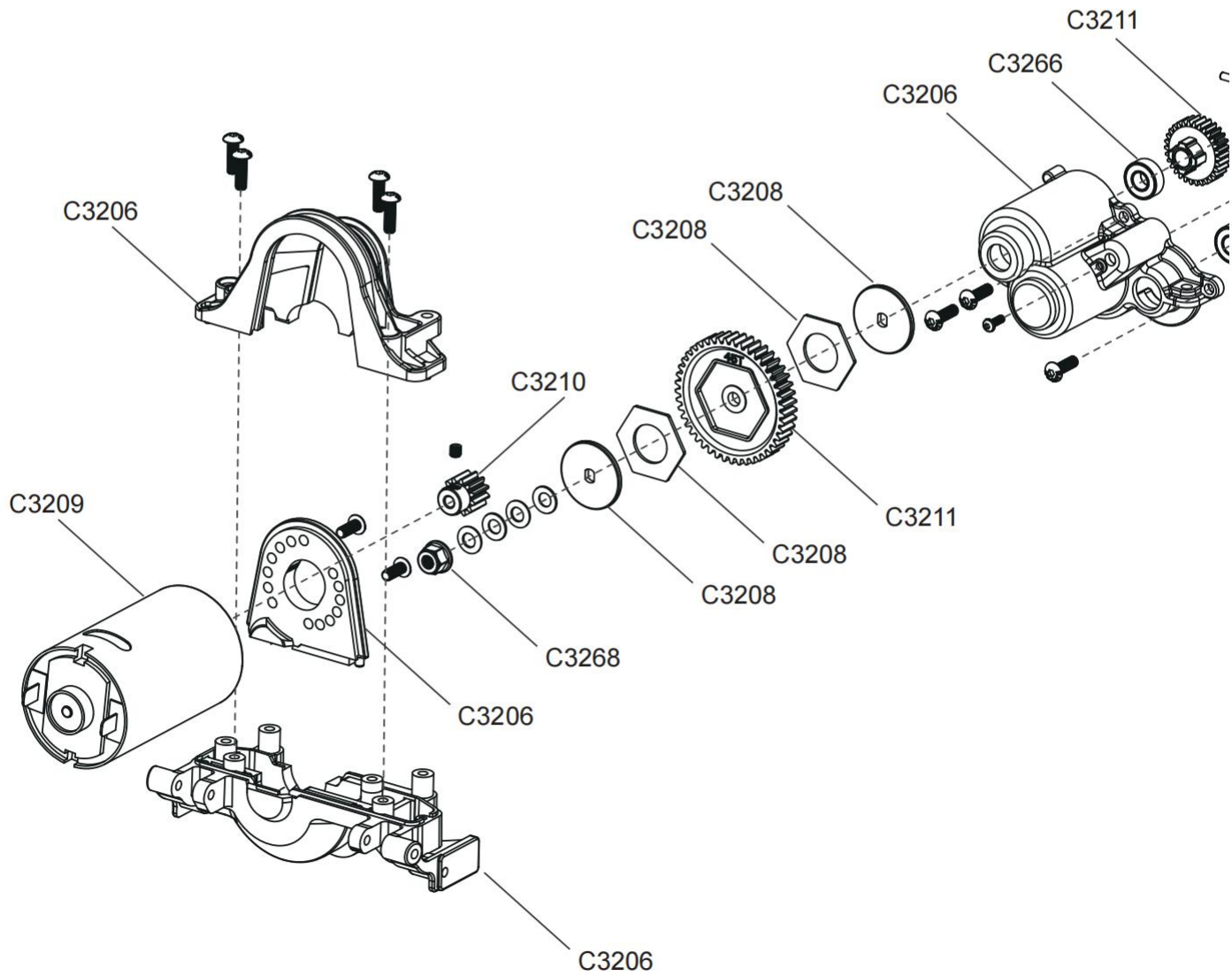

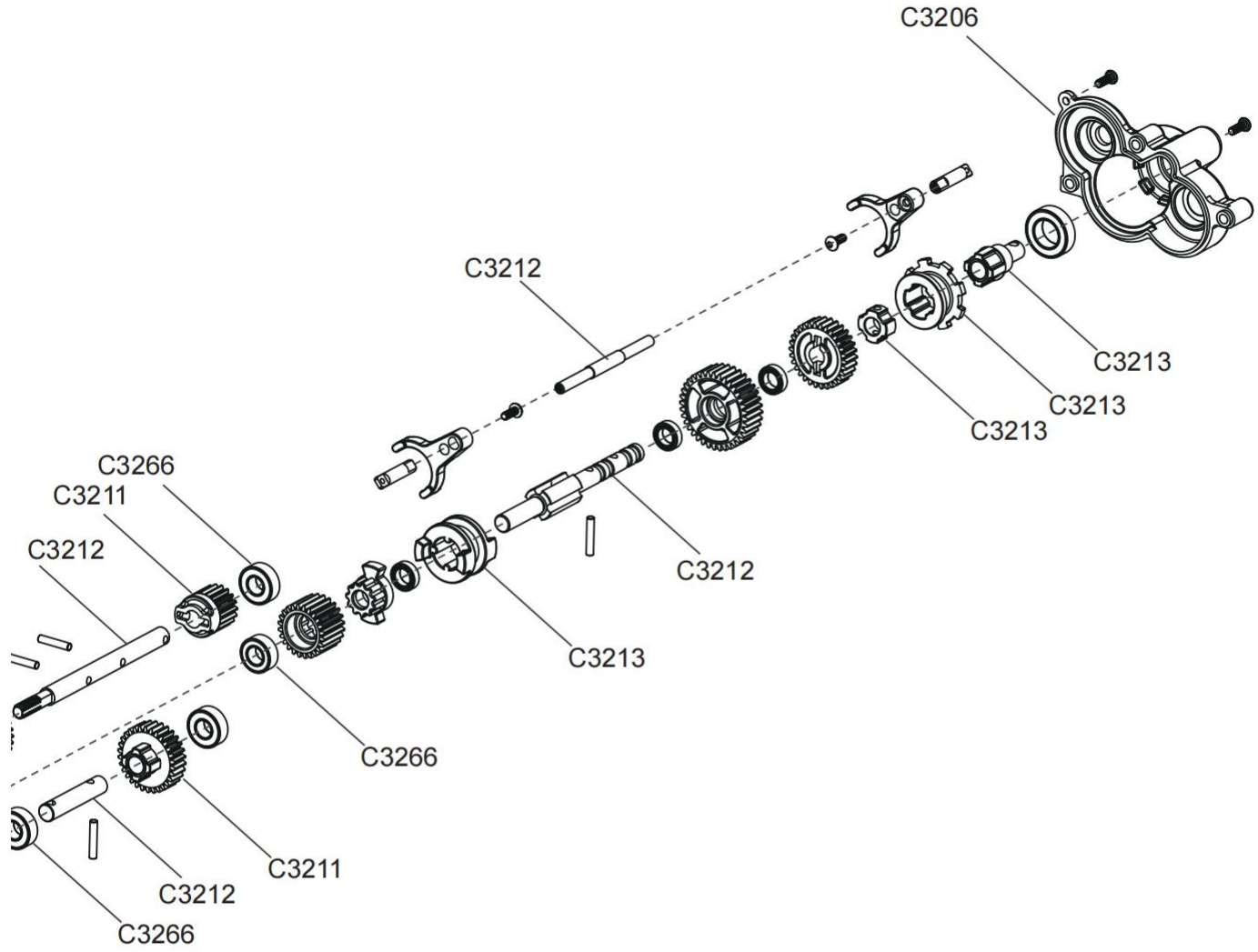

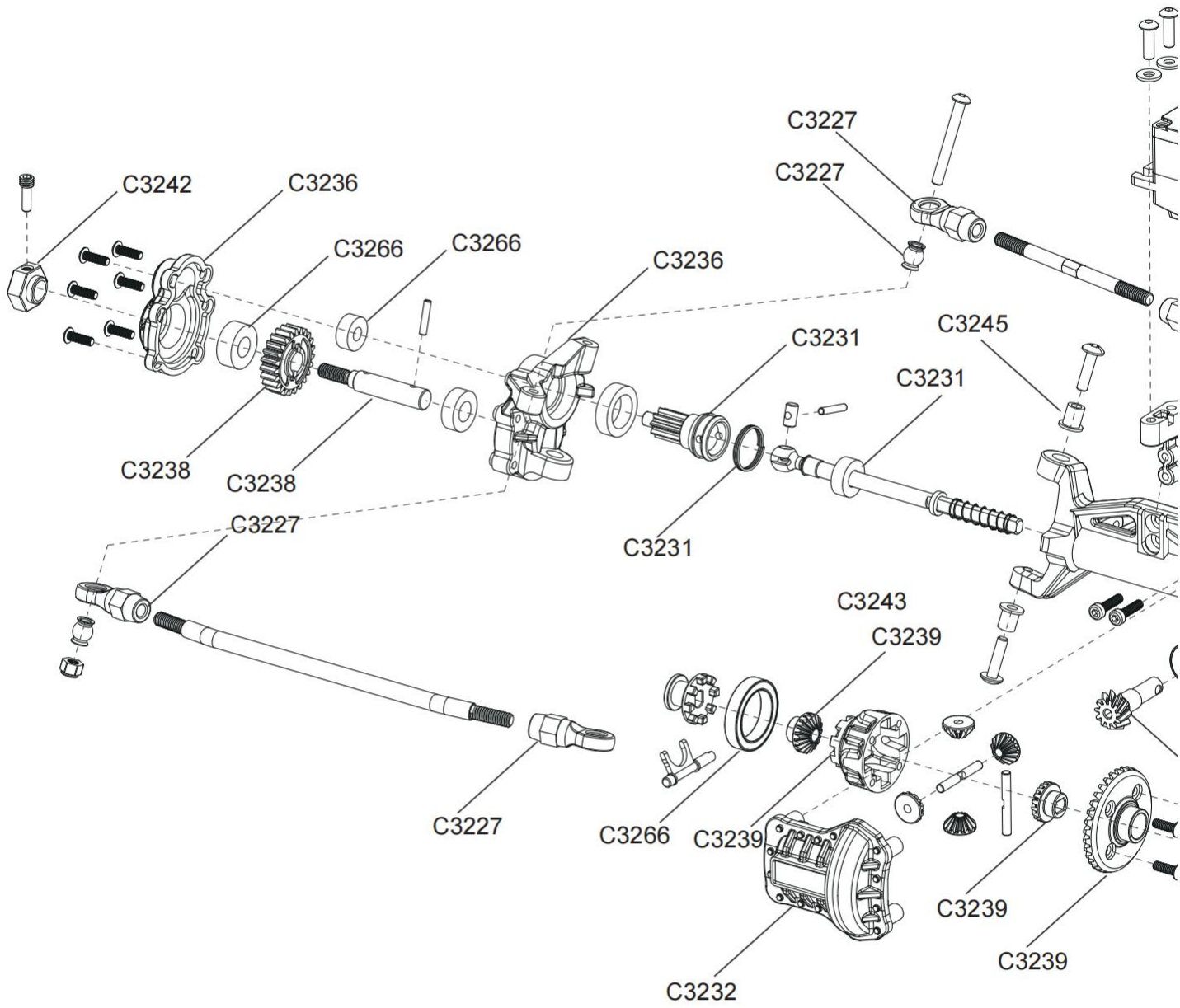

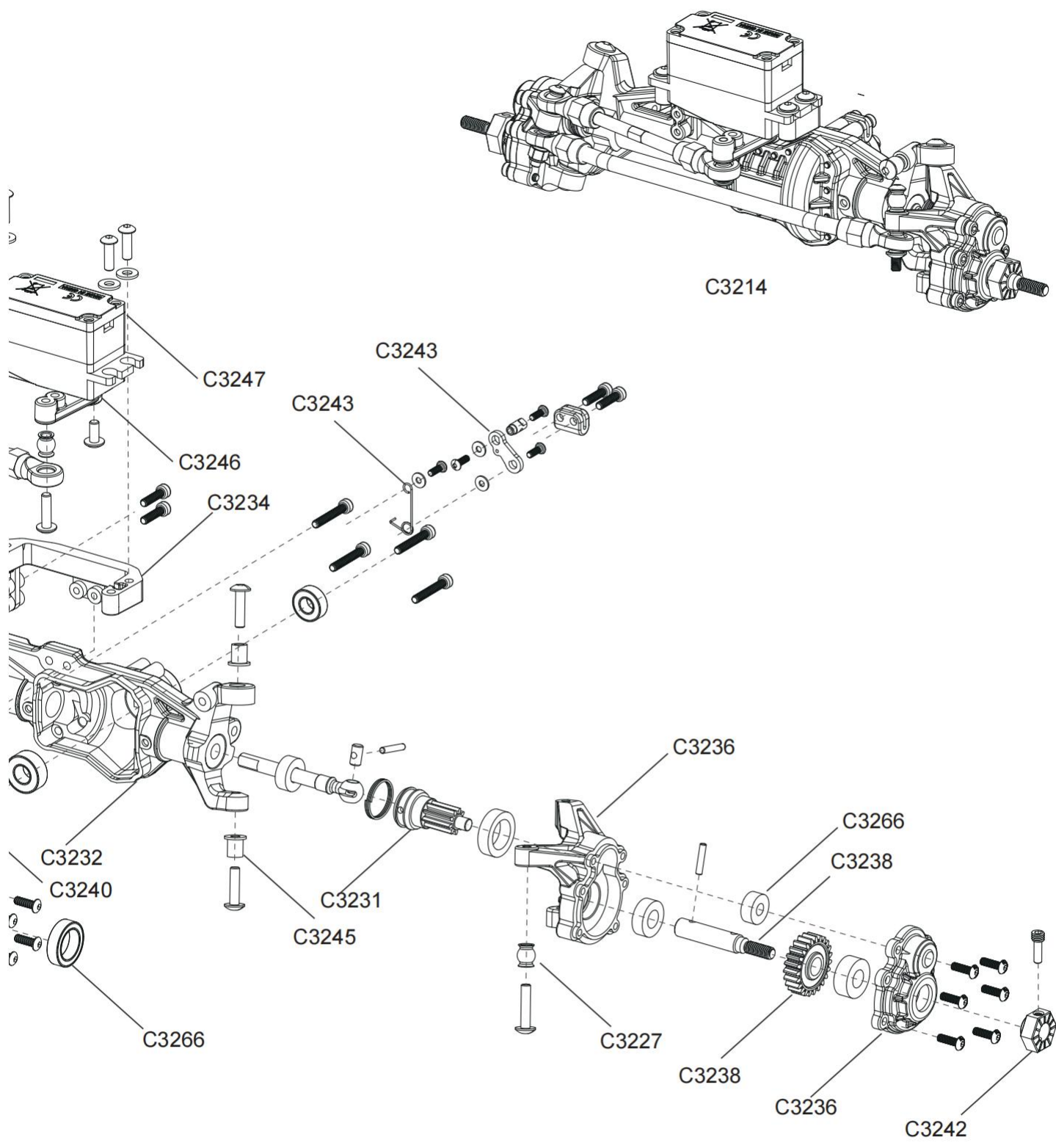

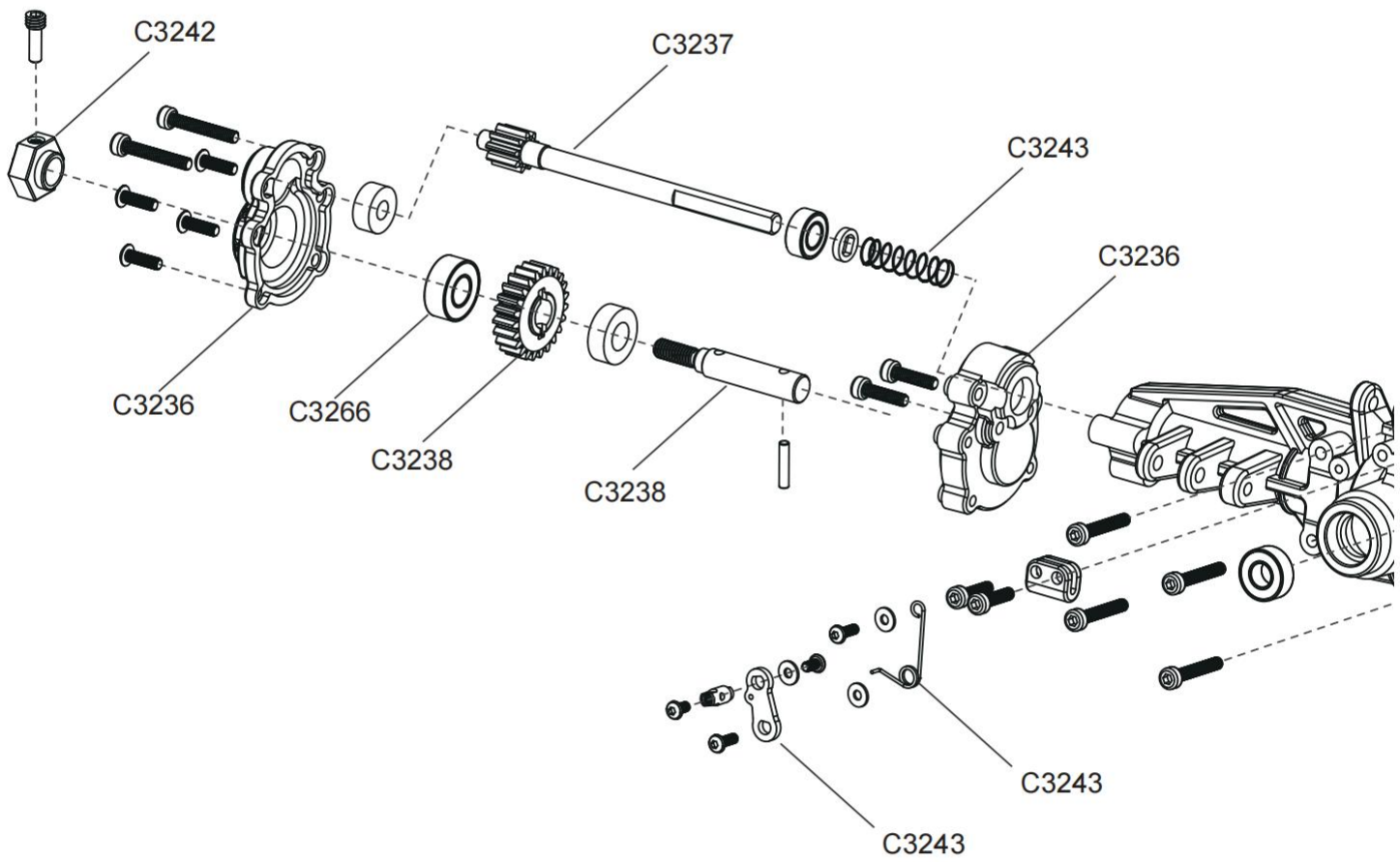

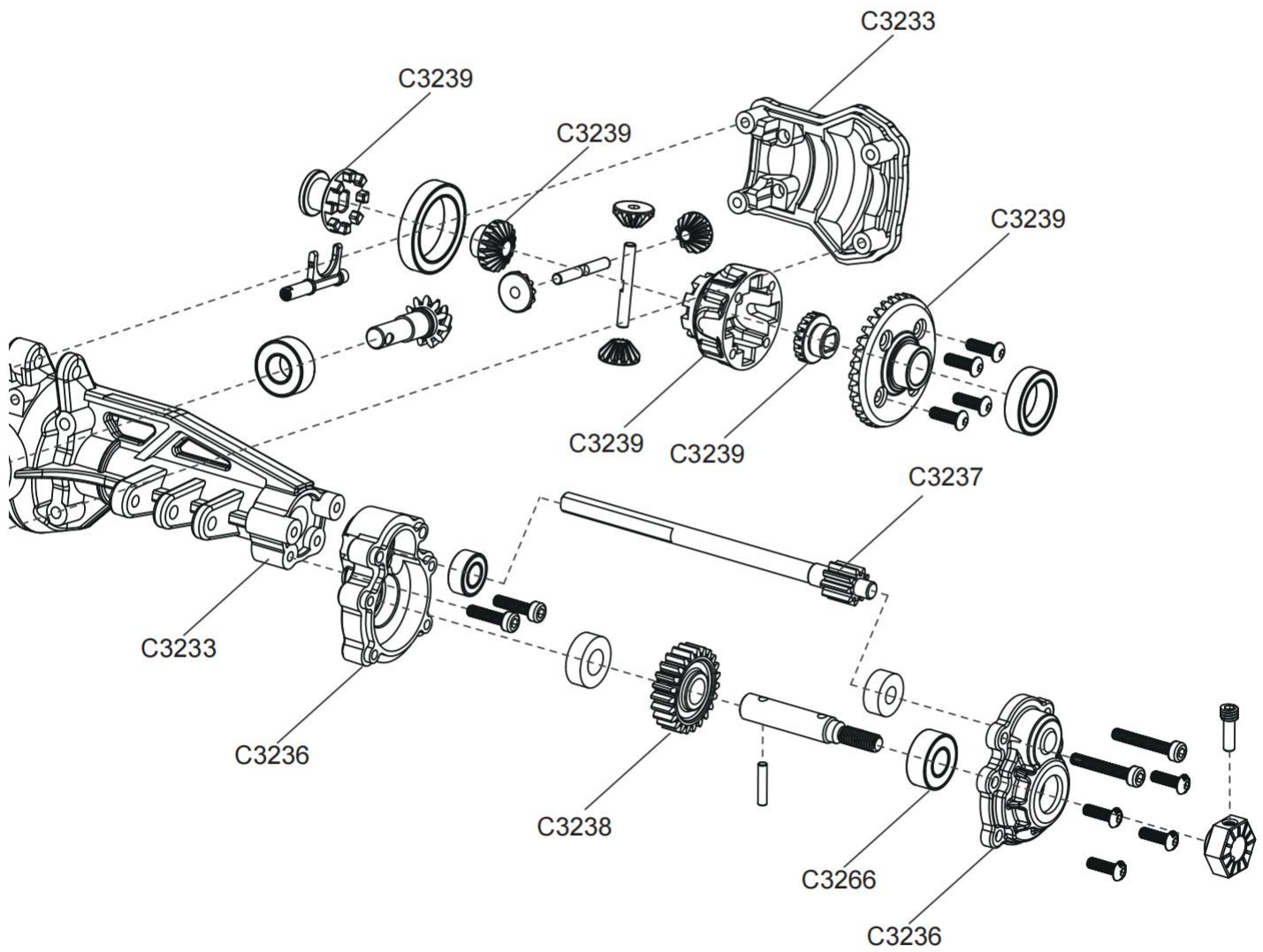
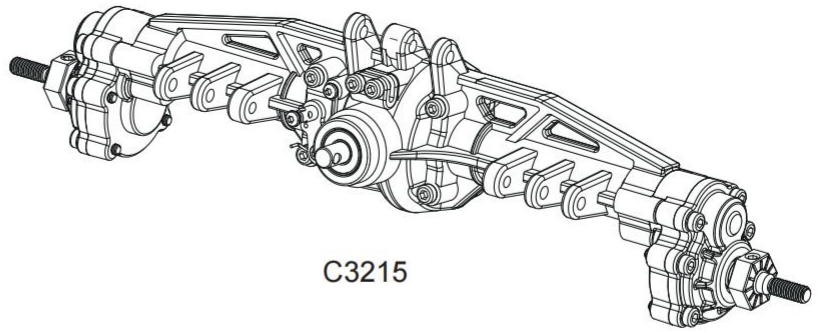

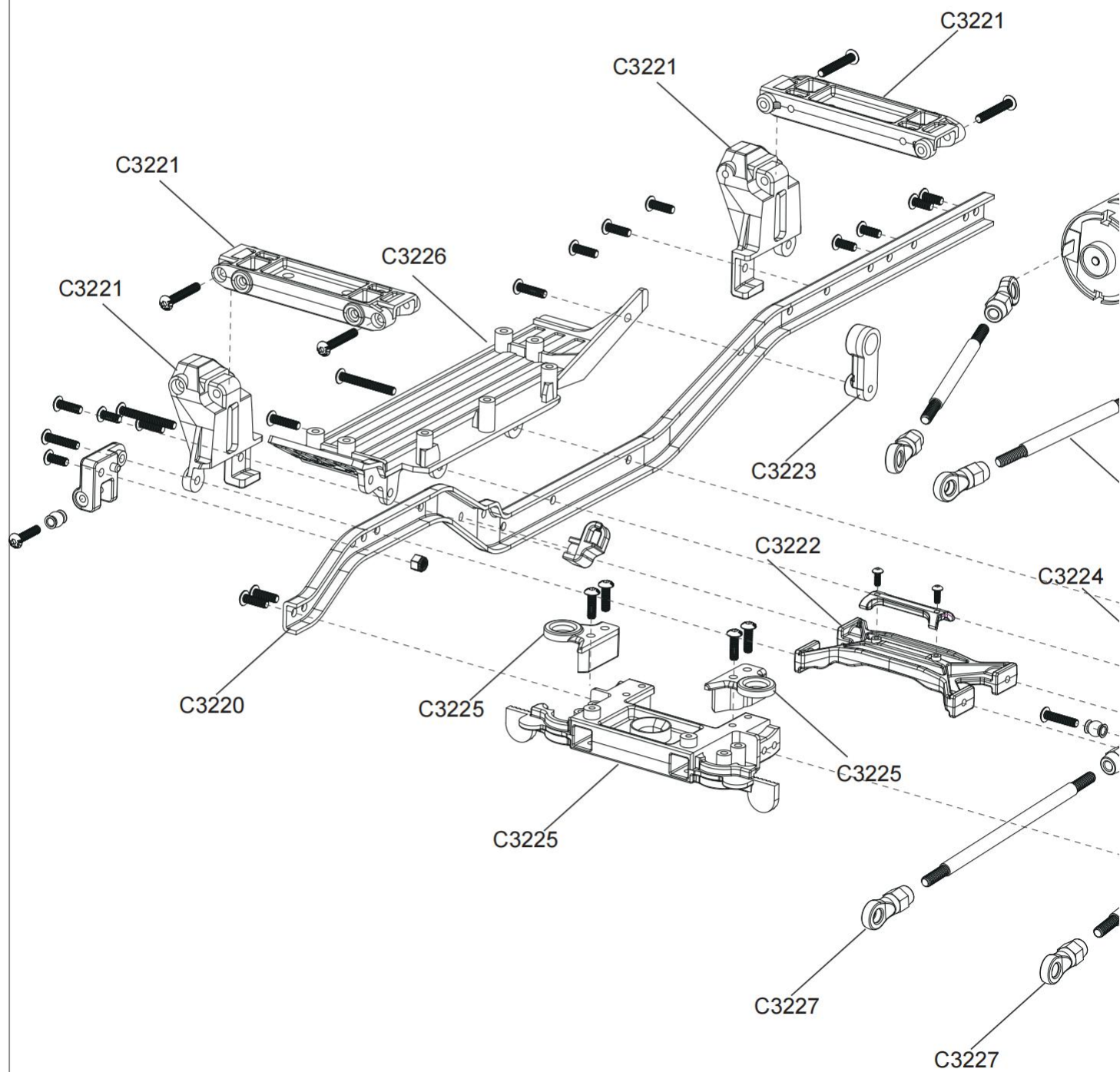

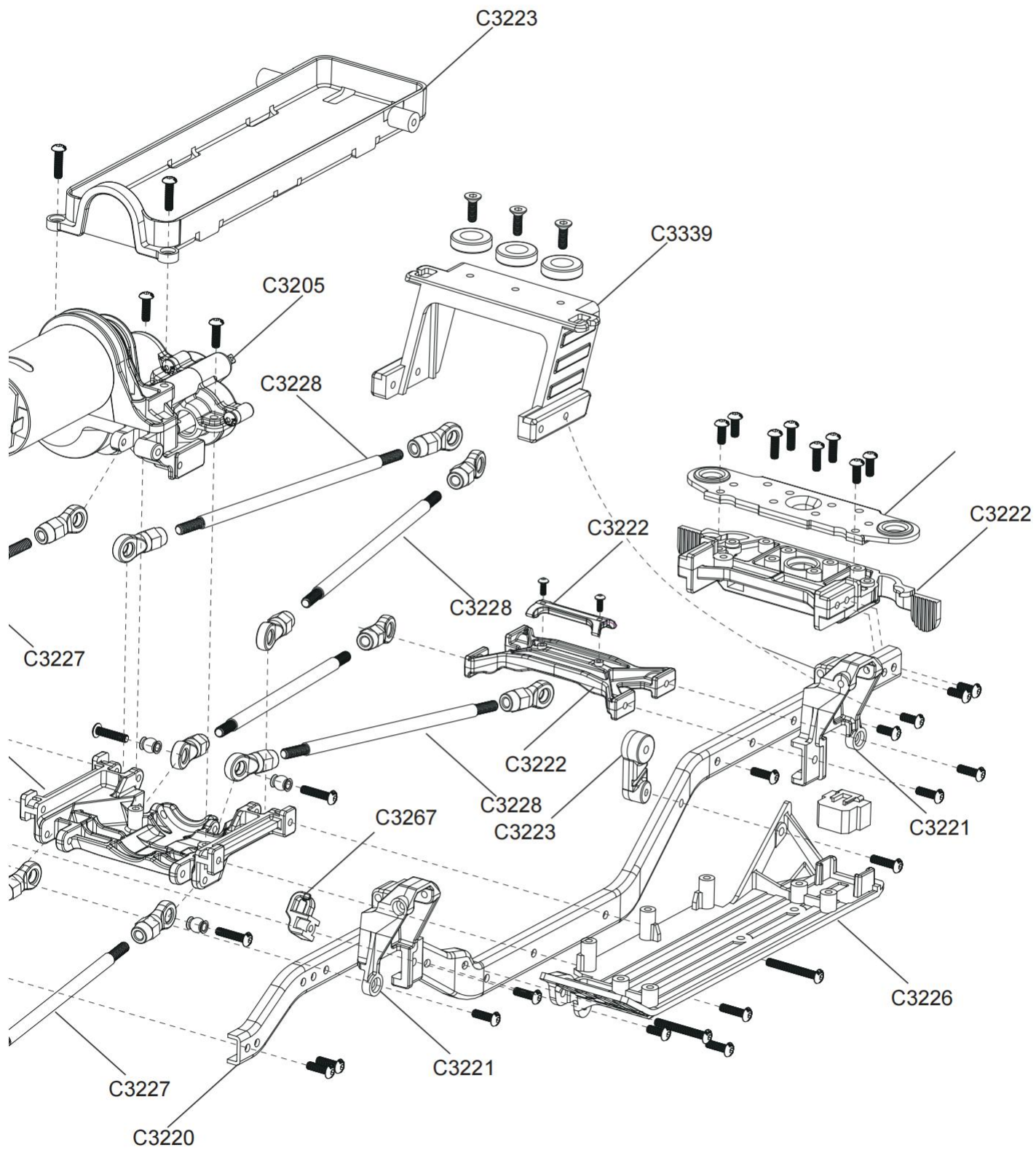

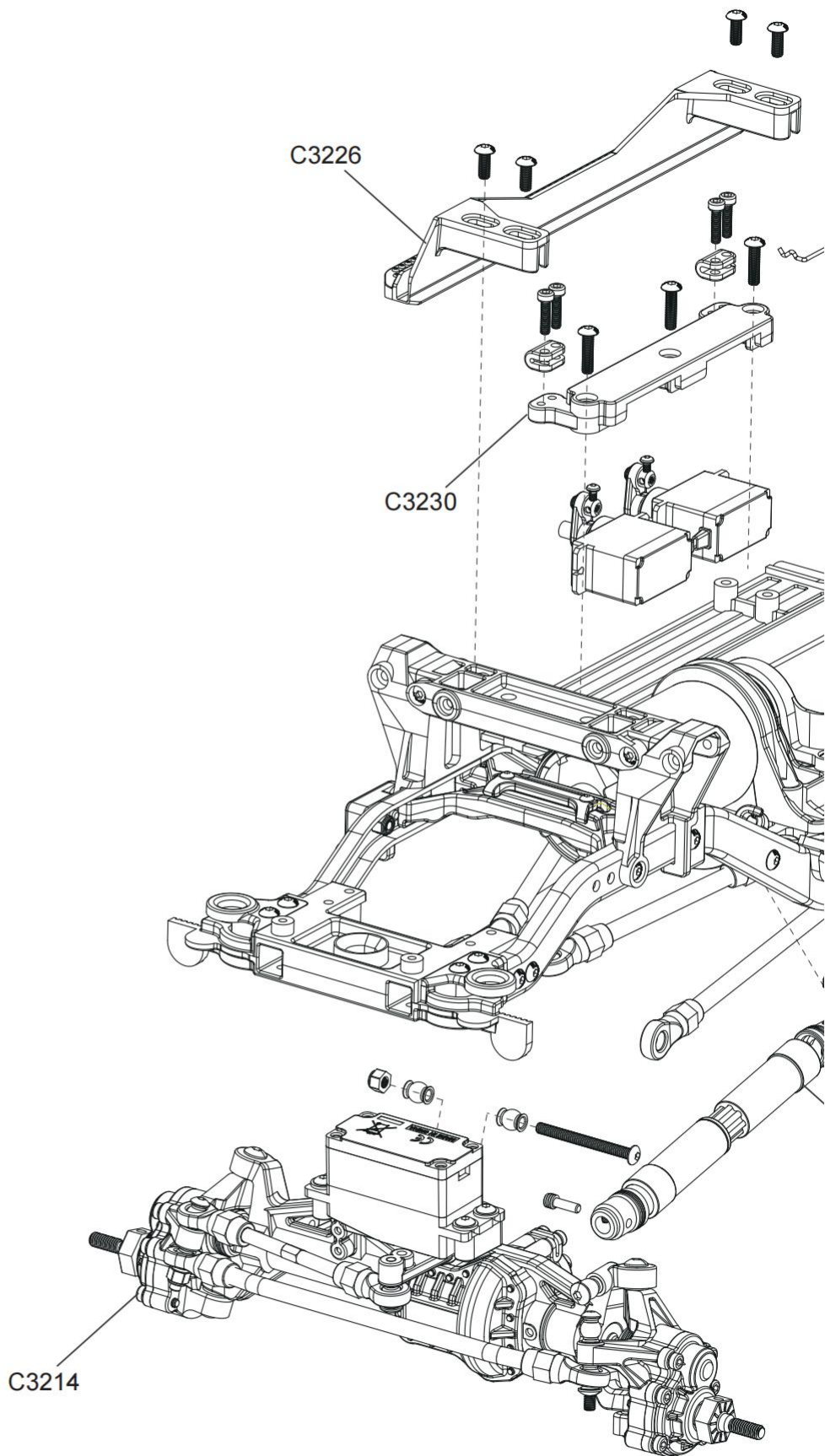

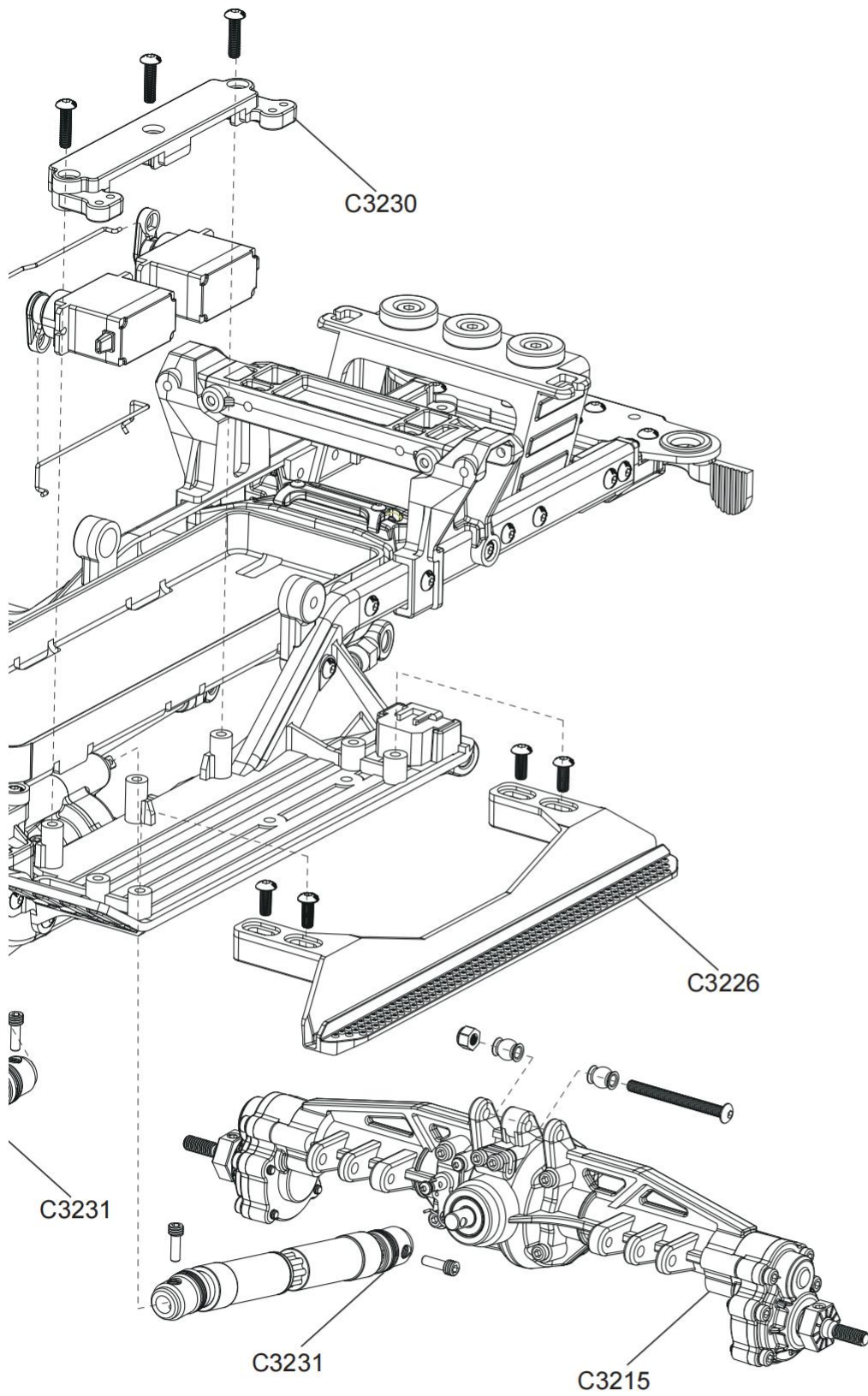

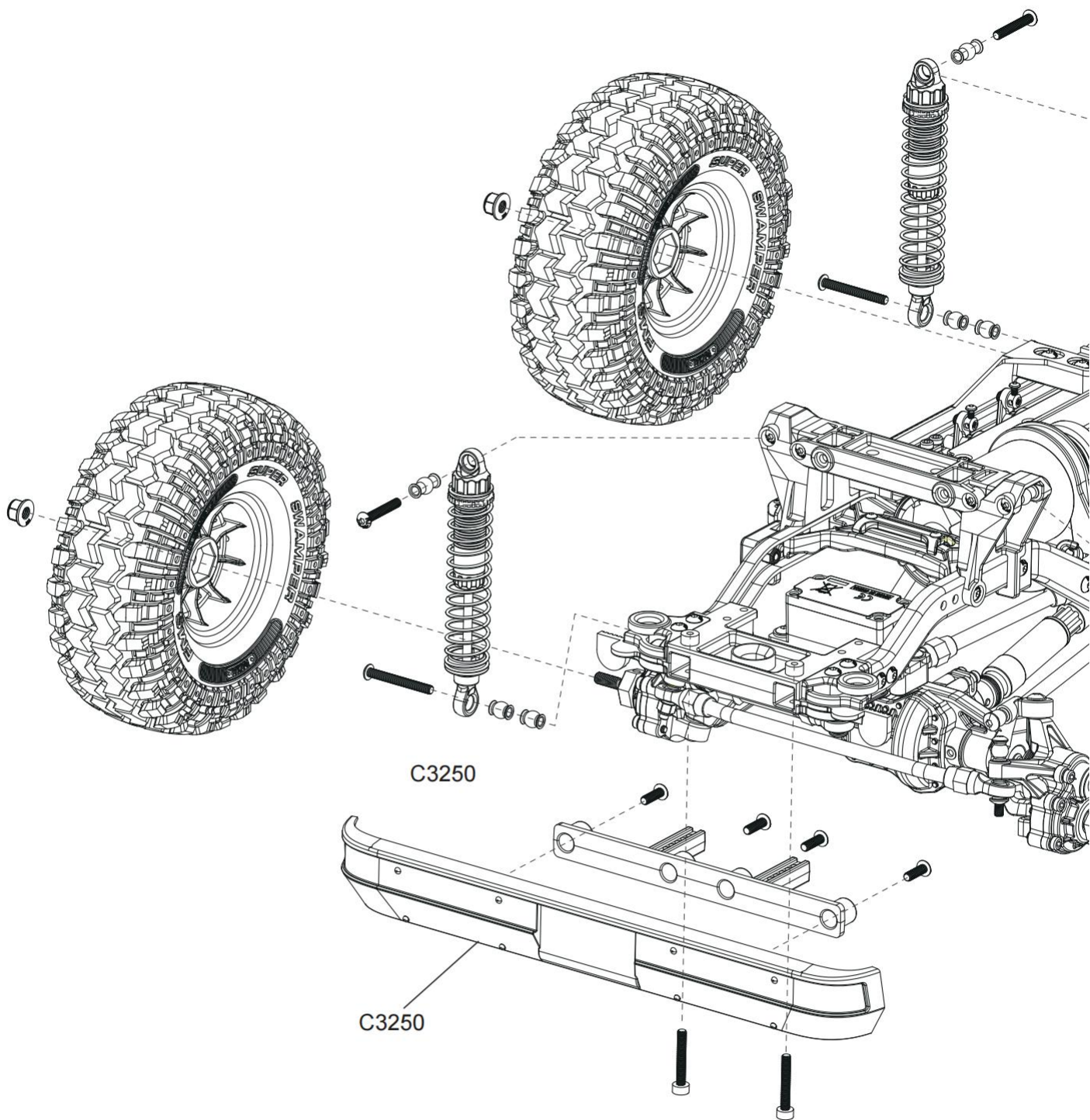

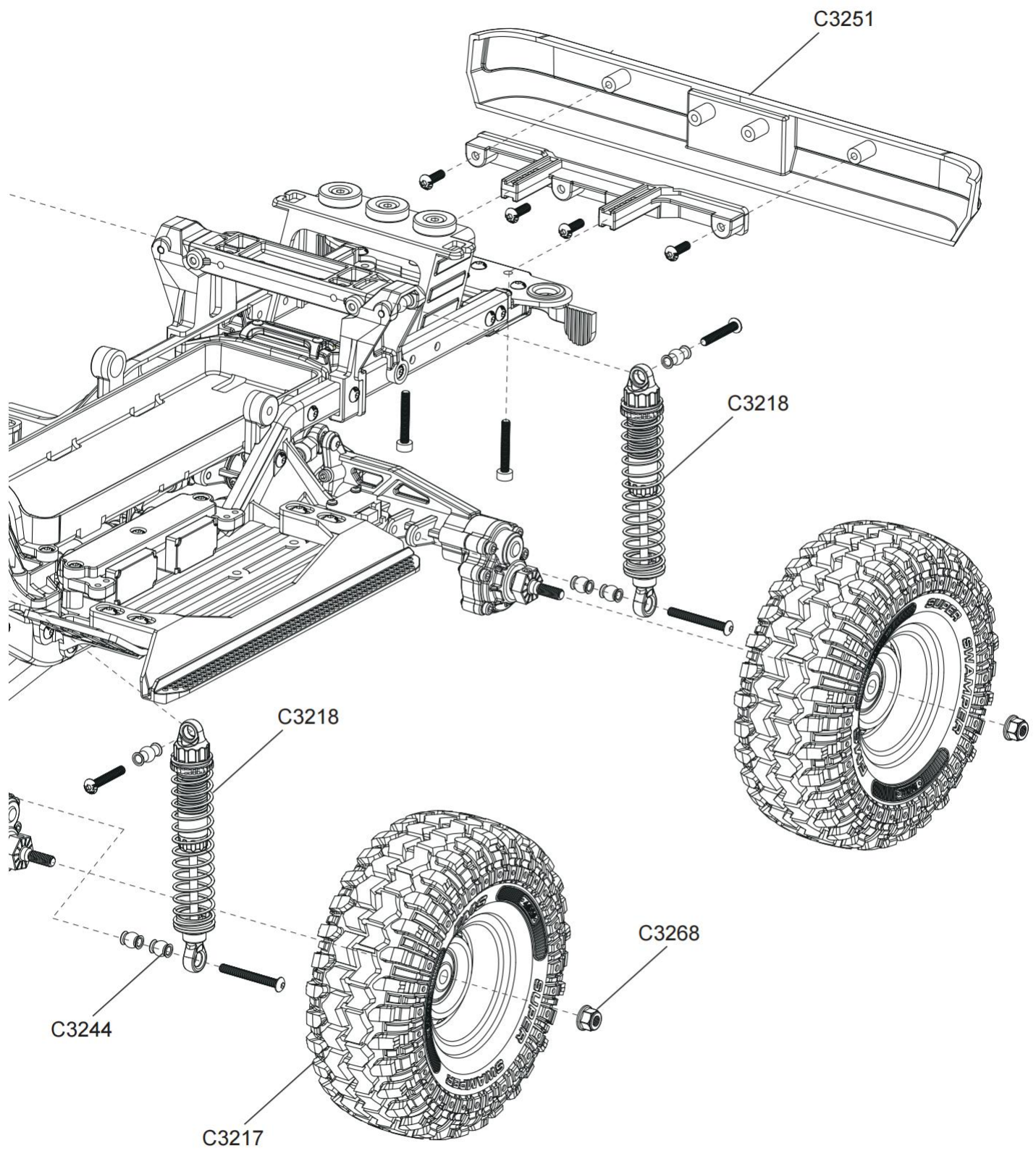

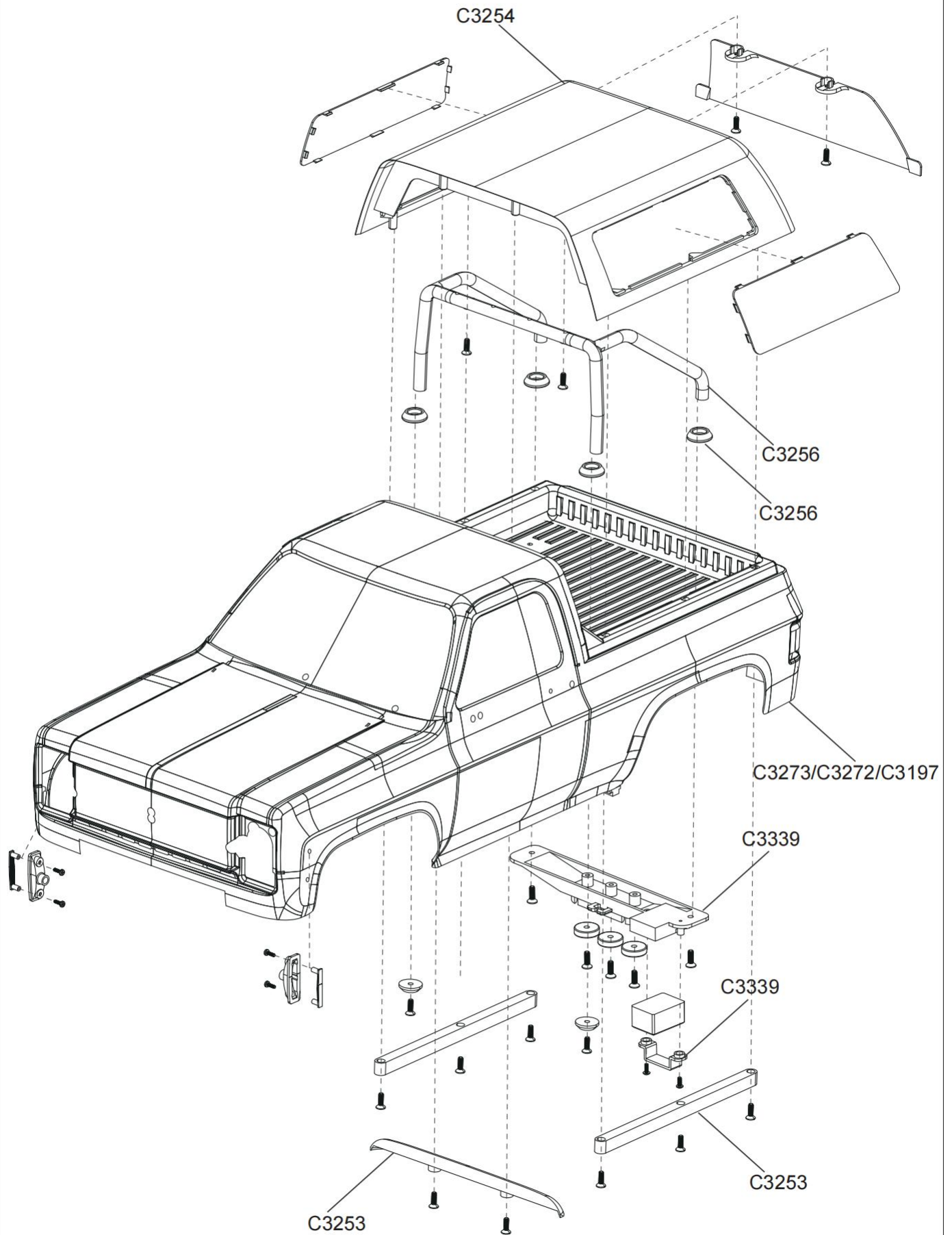

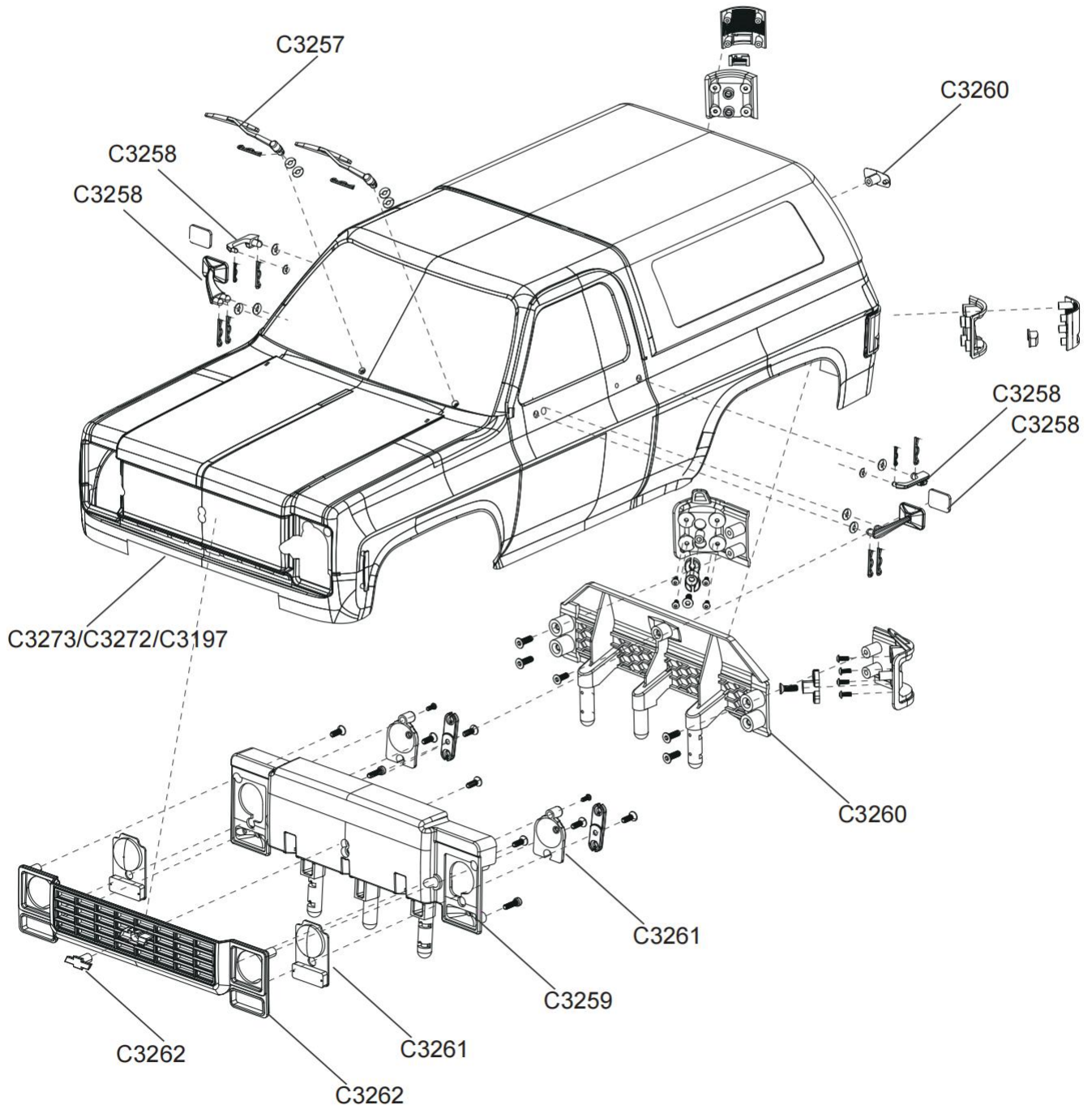

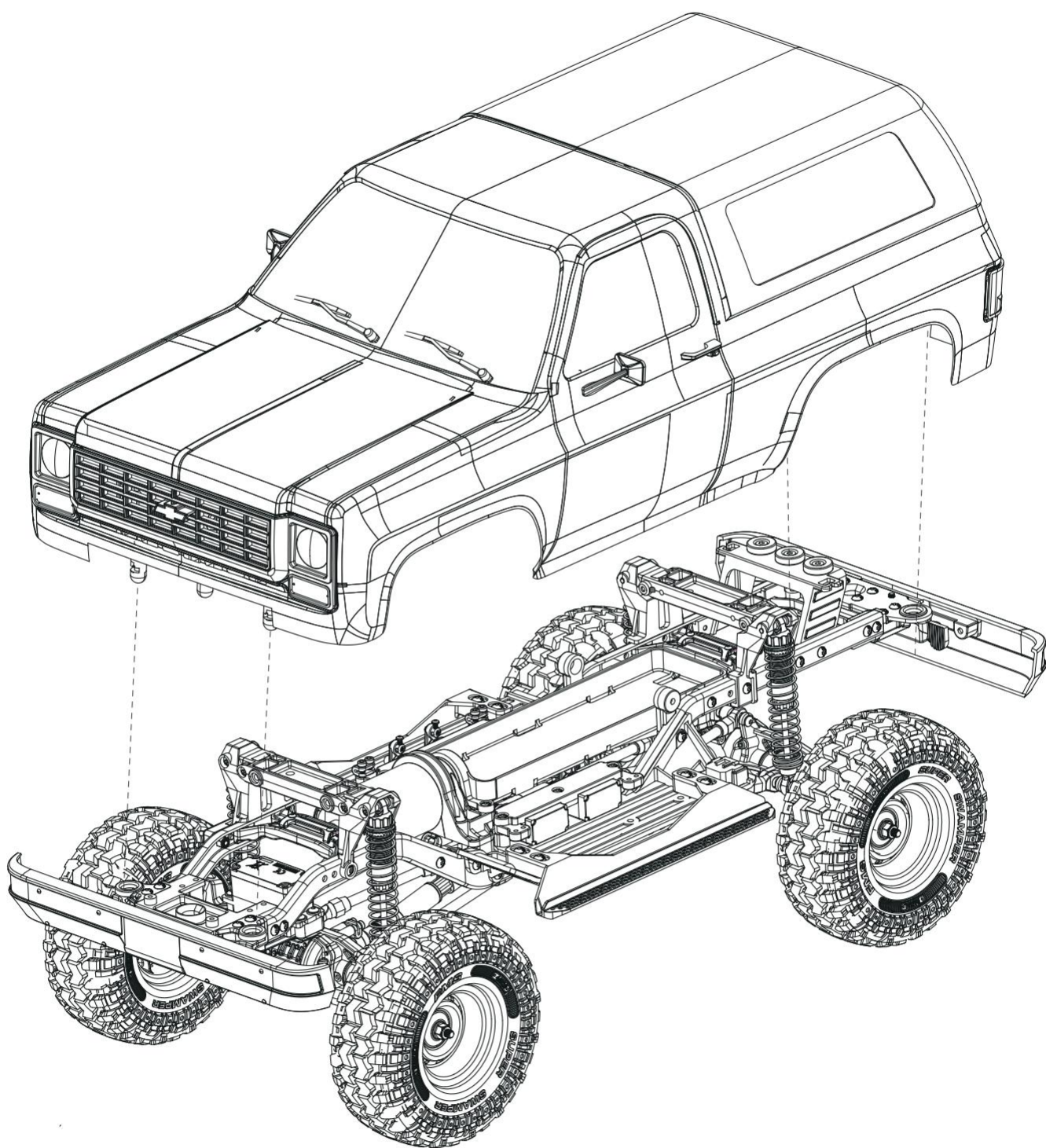

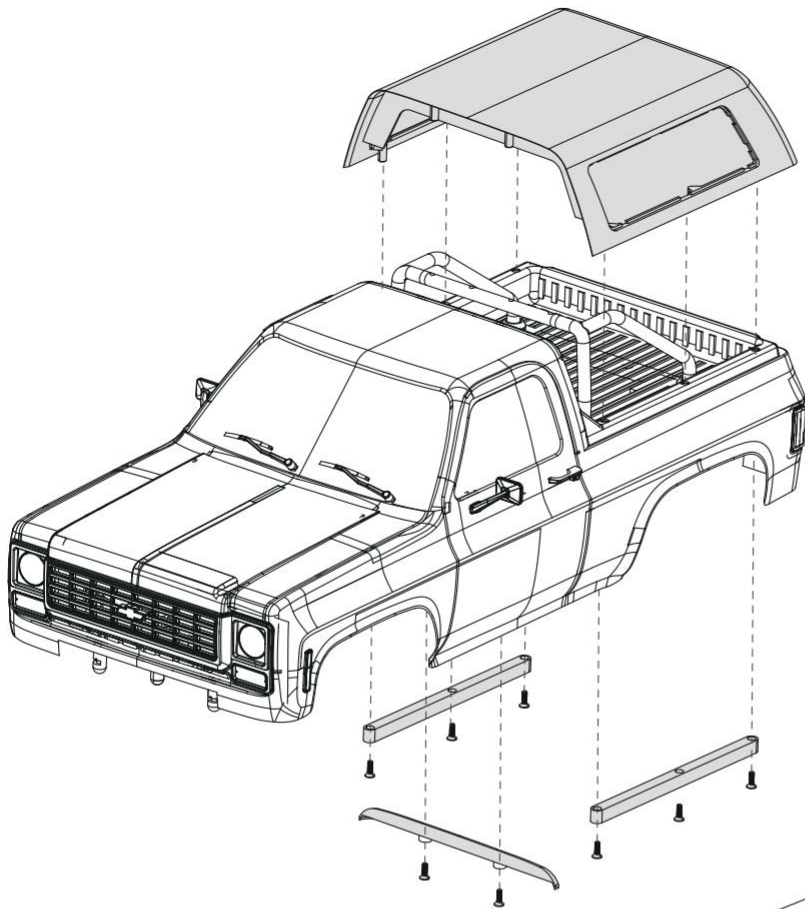

1. Use a hole opener to make holes in the shown screw mounting positions (aperture is about 3.2mm)
2. Secure the cargo cover in place using the attached screws and pressers.

1. 使用开孔器在图示螺丝安装位置开孔 (孔径约为3.2mm)。
2. 使用所附螺丝和压片将车斗盖固定到位。

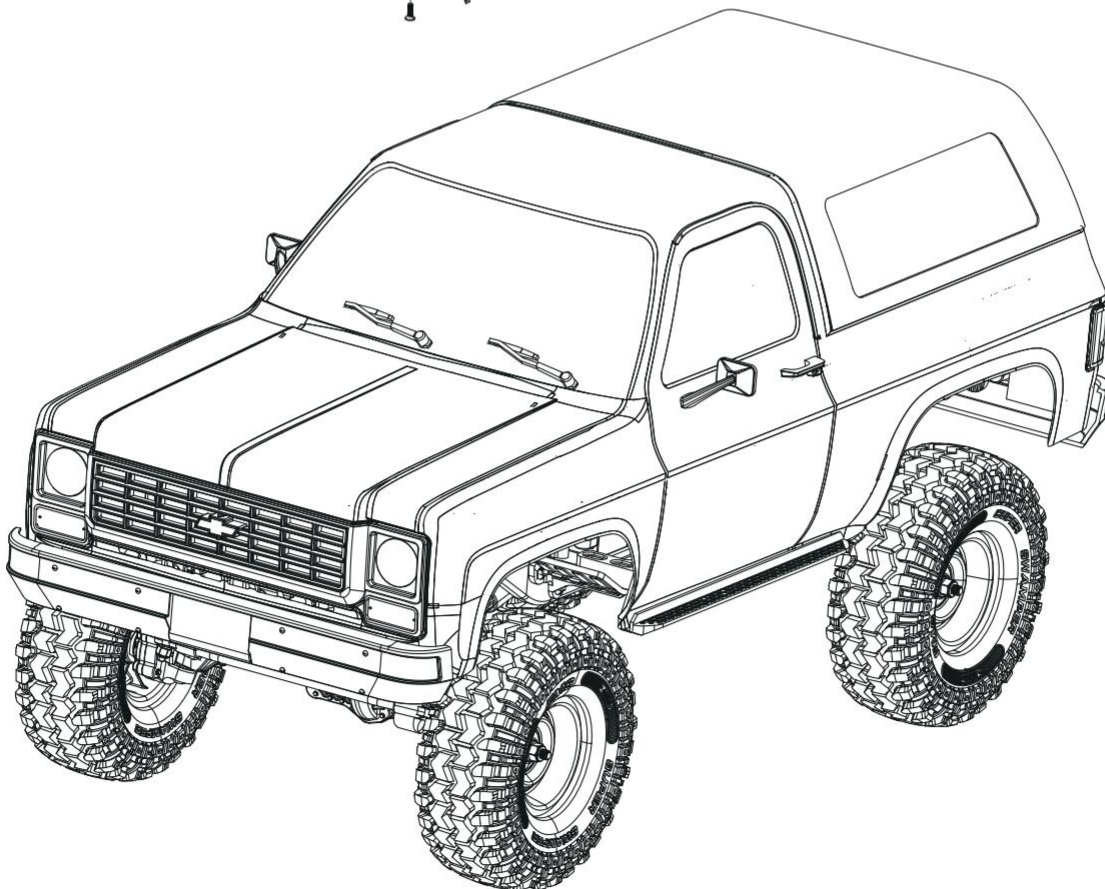

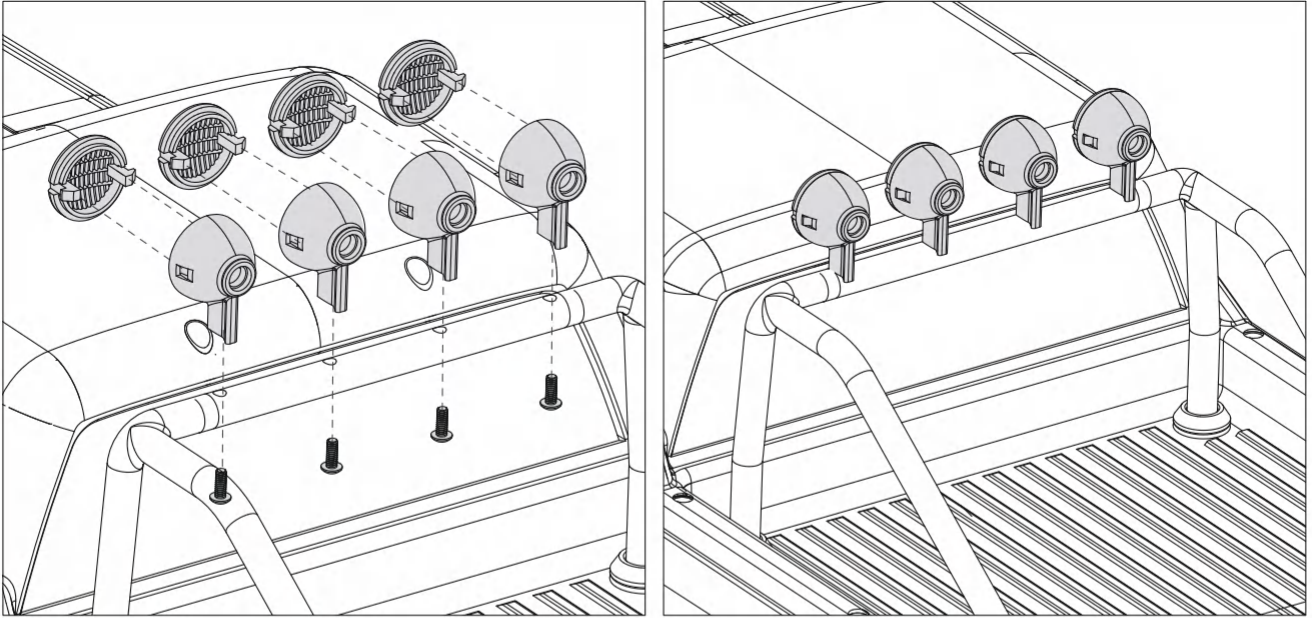

Press the transparent light pieces into the lamp cups, and then install the lamp cups on the anti-roll cage using the attached screws. Note: To facilitate installation, remove the anti-roll cage from the vehicle first.

先将透明灯片压扣进灯杯里,再使用所附螺丝将灯杯固定到防滚架上。注意:为方便安装,可先将防滚架从车斗拆下。

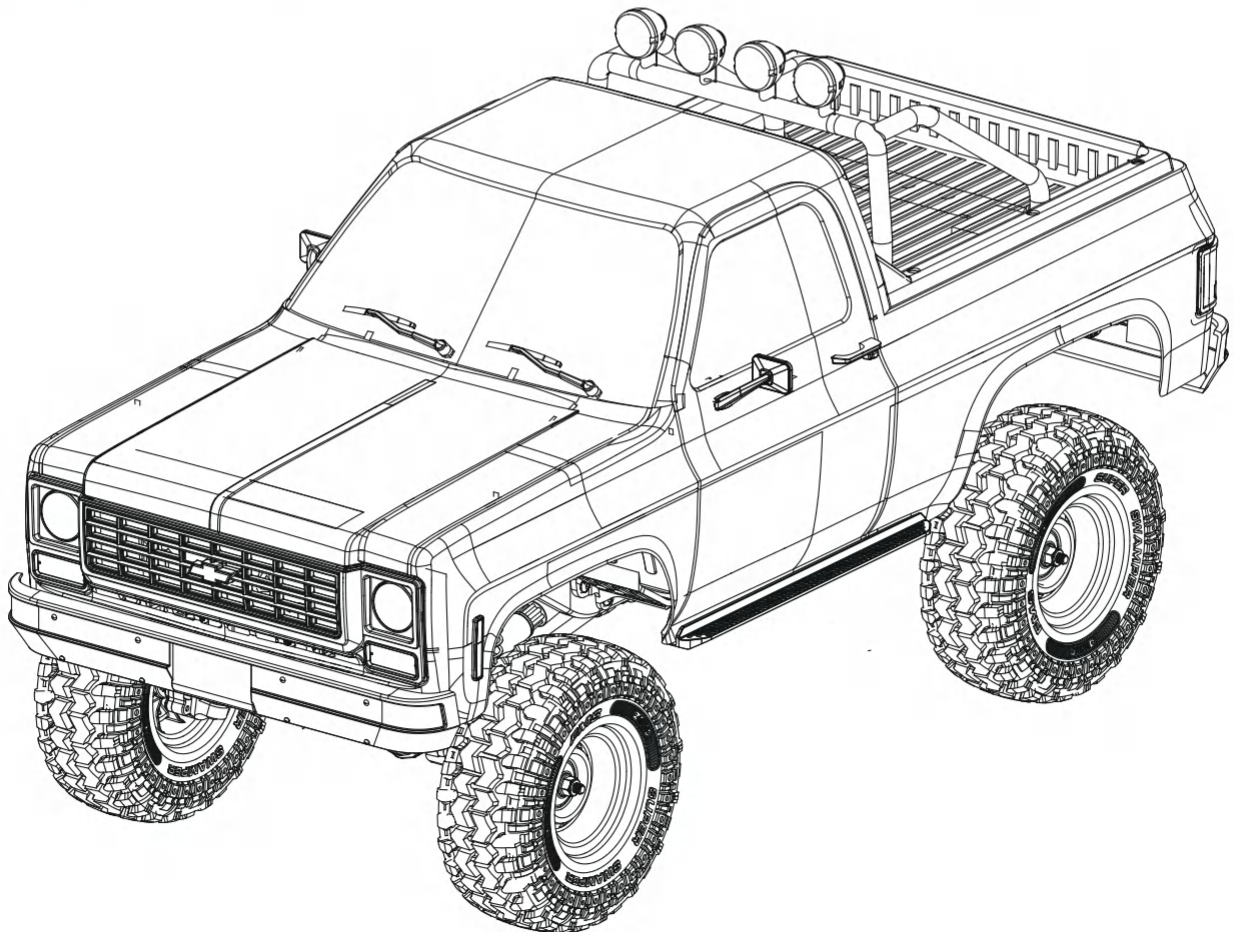

Foshan Zhengze Model Technology Co., Ltd.

Tel: +86-0757-26330080

E-mail: support@fmsmodel.com

Add: Unit A, Building 6, Jicheng Science and Technology Innovation Park,
Shunde, Foshan City, Guangdong Province, 528306

佛山市正泽模型科技有限公司

电话: 86-0757-26330080

邮箱: support@fmsmodel.com

地址及电话: 广东省佛山市顺德区北滘镇顺江社区三乐东路25号集成科创园 6栋

中国代理

车模

酷乐派模型 KLP Racing

蓝飞驰模型

老顽童模型

顶尖遥控模型

苏乐快捷模型

意帆模型 Well Model

航模

苏州雷飞航模车模

擎天模型

神鹰模型

mymtt的新店

天天向上模型

新动模型

