

## Specifications

Bore	Φ40.0mm	Stroke	32.0mm	Disp.	40.2cc	Applications	4-stroke glow 200 class
Weight (Approx.)	Main body : 1,260g / Muffler : 90g / Ignition : 100g			Practical speed	Approx. 1,800-8,000rpm	Max on ground	Approx. 6,500-7,500rpm
Propeller	19"x10"~ 21"x8"	Plug	CM-6	Battery for ignition system	Voltage: 6-12V, greater than 1,000mA ※		
Standard accessories	<ul style="list-style-type: none"> <li>Limit gauge (0.1t) for tappet adjustment 1pc</li> <li>Spark plug (CM-6) (Attached to the engine) 1pc</li> <li>Ignition system (w/sensor) 1set</li> <li>Anti-loosening nut 1pc</li> </ul>	<ul style="list-style-type: none"> <li>Wrench for tappet adjusting lock nut 1pc</li> <li>Muffler set 1set</li> <li>Plug wrench 1pc</li> <li>Hexagonal wrench 1set</li> </ul>	<ul style="list-style-type: none"> <li>Carburetor adjustment bar 1pc</li> <li>Choke bar 1pc</li> <li>Engine mount set 1set</li> </ul>				
Optional parts	<ul style="list-style-type: none"> <li>Filter with weight [G36-154]</li> <li>Aluminum spinner nut [120S-30]</li> </ul>	<ul style="list-style-type: none"> <li>Durable tube for Gasoline (1m) [G36-155]</li> <li>Tappet adjusting kit [120S-161]</li> </ul>	<ul style="list-style-type: none"> <li>Mount spacer [G40-169]</li> <li>Digital tachometer [G17-167]</li> </ul>				

※If you use a Li-Po, we recommend the spec less than 2,500mA capacity and less than 30C discharge rate

### 1. Fuel

- The fuel is a mixture of commercial regular gasoline and reliable oil for 2-stroke engines.
- [Example of oil recommendation]
  - Klotz KL-200 Original Techniplate • Deluxe Materials PowerModel 2T-S • ENEOS RACING SPEC PRO-2T (SAITO STANDARD) etc.

If such oils are not available in your country, then please ask the official SAITO distributor in your country for an alternative.
- Be sure to use the mixture "gasoline : oil = 15~20 : 1" by volume ratio. (Ex. 1000ml of gasoline should be mixed with more than 50ml of oil).
- In Break-in process, use 15:1 mixed fuel to ensure the best lubrication for initial run.
- Any damage caused by the fuel used, in which the oil ratio is lower than 20:1 ratio, is not warranted.
- Do not use gasoline ethanol mixed. It may cause not only power loss but also corrosion inside the engine.

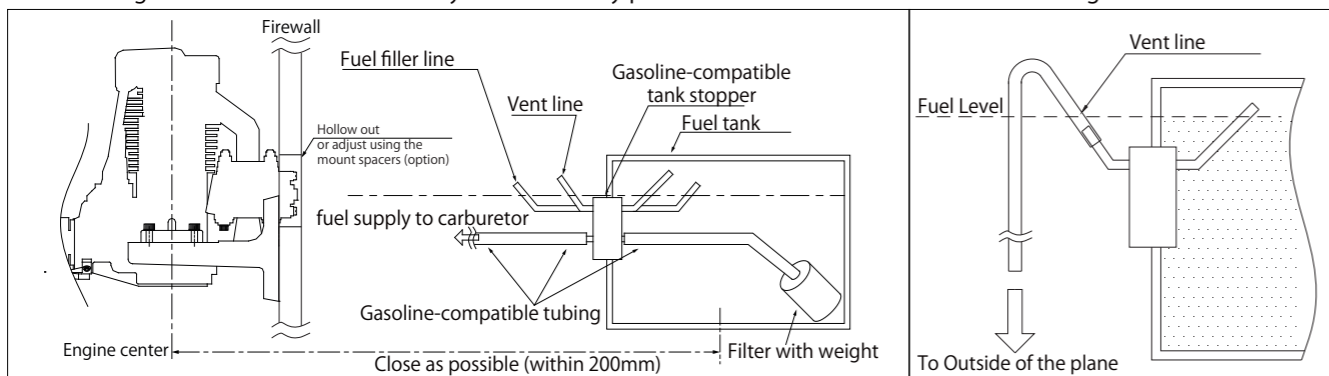

### 2. Ignition

- Place the main unit as far from other electrical devices as possible.
- Place the two switches of the ignition and the RC receiver as far from each other as possible.
- (1) Plug cord (meshed high tension cord)  
Insert the cap deeply onto the plug to make sure it will not come off.
- (2) Sensor cord  
Connect with the cord from the sensor attached to the engine.
- (3) Battery cord (black / red cord)  
Use a fully charged battery that has adequate spec. (6-12V, more than 1000mA is recommended.). Between the battery and main unit, make sure to install a heavy duty switch whose capacity is higher than 3A.
- (4) Tachometer cord (optional)  
Connect the digital tachometer (Option). Otherwise the connector is normally vacant.

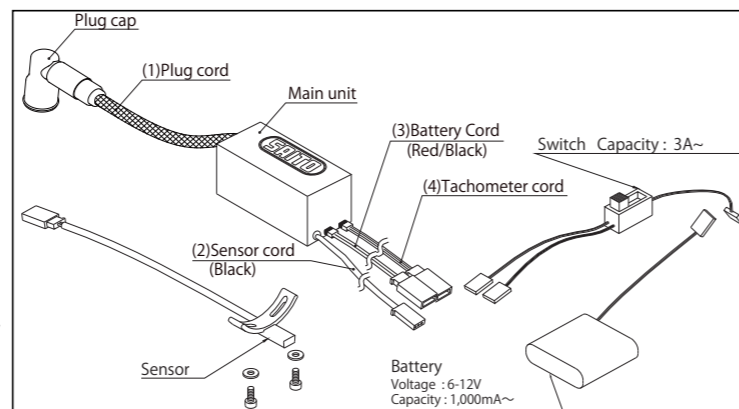

### 3. Propeller

- The Standard prop is Mejlzlik D20"xP8" which brings approx. 6,900rpm (or Falcon D20"xP8" brings approx. 6,400rpm).  
Larger size or greater pitch can cause engine broken due to overload.
- Use a well-balanced one. Never use the propeller that has been scratched or damaged even if slightly.
- As the propeller is compressed slightly, tighten the propeller nut every hour of operation.

### 4. Method of choke (No need when you use starter)

※Choking is the means by which fuel is fed to the engine when you start it by hand flipping. Thus it is unnecessary when using starter.

- Starting with a electric starter is recommended for safety.
- In advance, make a thin hole in the cowling to insert the choke bar / slow needle adjustment bar.
- During choking, be sure to turn off the ignition switch.
- As shown in the fig, pass the choke bar (with M3.5 thread on its tip) through the hole in the cowling. Then turn the bar to insert into the M3.5 internal thread at the center of the throttle lever.
- Fully close the throttle and pull the choke bar and fix it with a clip or clamp as shown in the fig so that it may not go back to the previous position.
- Grasp the prop by hand and turn it several times in the direction of normal operation (CCW) until the carburetor generates hissing-like sound. After hearing this sound for about 5 times, quickly flip the prop approximately 10 times.
- Remove the choke bar. Then power on the ignition system and flip the prop quickly to start the engine. If the engine doesn't start, repeat the choking procedure.

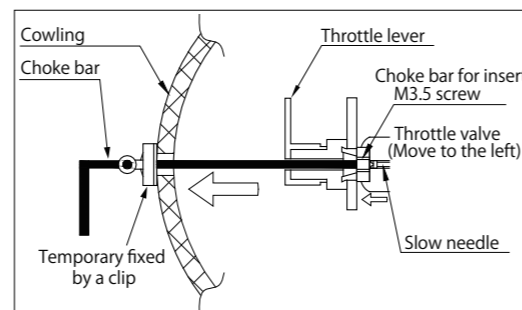

### 5. Break-in MOST IMPORTANT!!

- Prop-recommendation : 20"x8" carbon prop for break-in.
- Use 15:1 fuel:oil ratio for break-in.
- Never make the fuel mixture lean during Break-in. It could cause seizure even during idling or low speed running.
- Before starting the engine, open the main needle Approx. 3 turns and slow needle Approx. 5 turns open (CCW) from fully closed.
- Start the engine (using a starter is recommended for safety).
- Soon after starting, Open the throttle gradually up to full open. In the meantime turn the main needle CCW. Continue to turn the main needle CCW until the RPM declines (to approx. 4,000rpm), keeping the throttle fully opened.
- If opening main needle doesn't drop RPM, then open the slow needle too.
- Run in this very rich condition for 1 liter of fuel.
- Now "initial" break-in is done.

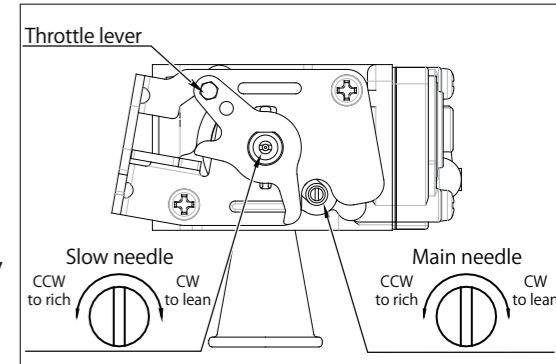

### 6. Adjustment of carburetor after initial break-in.

#### ◇Needle reference position (Set after initial break-in)

- Start the engine after adjusting the needle to the following reference value.
- Main needle: Approx. 2~2.5 turns CCW from fully closed
- Slow needle: Approx. 4.5~5 turns CCW from fully closed (Then throttle should be fully closed)
- Actually, the best position of the needles vary depending on the prop, temperature, humidity and so on. Please adjust as necessary after observing the engine performance during flight.

#### ◇Peak adjustment

- After starting the engine, warm up for approx. 30 seconds at low speed.
- Achieve the peak at full throttle.  
→Turn the main needle CW gradually to the position where the RPM is greatest (the peak). Continuing to turn the needle CW past the peak could lead to seizure so turn it slowly and carefully. If the RPM suddenly decreases after passing the peak, **instantly turn the main needle CCW** to again increase the RPM. Otherwise it could damage the engine seriously.
- Once achieving peak RPM, return the throttle to low speed. Make a note of the position of main needle at the peak at that time. (How many turns you did CW based on the reference value.)

#### ◇Slow needle Adjustment

- After achieving peak RPM, next is slow needle adjustment. Open the throttle from low RPM to full throttle quickly.
- If the engine hesitates for a moment or stalls before the engine reaches max RPM, it's because the mixture is too lean. Then turn the slow needle CCW slightly.
- If the engine is slow to reach peak RPM (full throttle set), it's because the mixture is too rich. Then turn the slow needle CW slightly.
- Adjust the slow needle as above until the RPM follows the throttle movement smoothly. The important point is to adjust the slow needle AFTER the main needle has been adjusted to its peak.
- Now break-in at ground level is done. Adjust tappets by the method described later.

#### ◇Pre-flight / Flight adjustment

- When the slow needle adjustment is done, check the response by revving up from low speed to full throttle quickly several times.
- Open the throttle fully and turn the main needle CCW approx. 60~90 degrees from the peak position. This is to make the fuel mixture richer in the air where the RPM get higher than on the ground.
- After all adjustments are made, fly your aircraft and fine tune the engine according to the situation. Basically tuning should be done with the main needle. Readjustment of the slow needle is rarely needed if the first adjustment of the slow needle has been done successfully.

### 7. Tappet adjustment

The valve clearance should be checked and adjusted after break-in and every time after two hours while the engine is cold. Before adjusting tappet gaps, tighten up the screws around cylinders etc.

1. Remove the spark plug and rocker arm covers of the cylinder. Then turn the prop CCW by hand to place the piston at TDC of compression stroke.
2. Loosen the lock nut and adjust the gap by hexagonal wrench until you get the correct gap for both of intake & exhaust.
3. Once the gap is set, tighten the lock nut and attach the plug and covers.
4. Turn the prop by hand to check if the compression is enough. If the gap is less than 0, the valve is always opened slightly and will lose compression. Then adjust again.

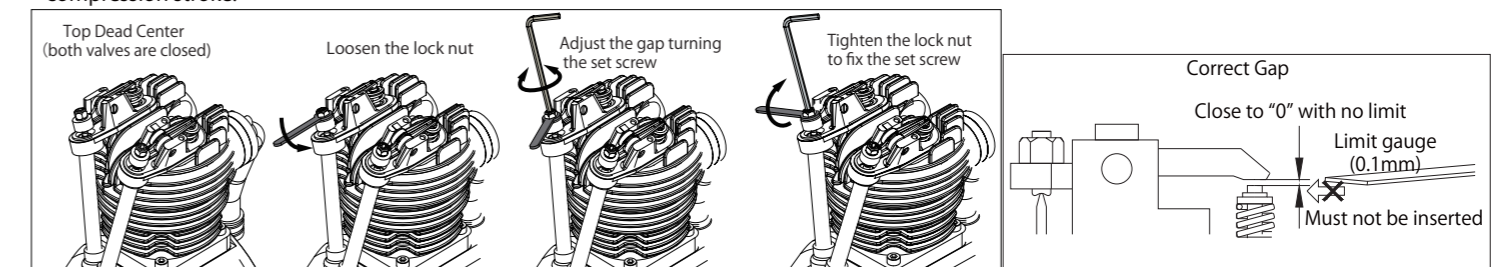

#### Note:

- As it uses oil-mixed fuel, the plane may sometimes get dirty from the exhaust.
- Use a reliable and well-balanced prop. Otherwise it may cause an abnormal vibration and could result in a serious accident.
- During operation, all engine screws can loosen due to metal heat expansion. Check and tighten occasionally.
- When the exhaust valve gets dull by carbon or sludge especially in cold atmosphere, remove the rocker cover and apply some anti-rust spray to the exhaust valve to help the valve to move smoothly.
- Pay attention to the surroundings so as not to disturb others by noise and exhaust.
- Always keep spectators behind the engine when operating the engine.

- As exhaust smoke is harmful, be careful not to breathe in or otherwise expose yourself to its harmful effects.
- Pay attention not to touch the rotating propeller when starting engine, and move to rear side of the aircraft once the engine is started.
- All responsibilities for the use of the engine, and other obligations and responsibilities based on laws, regulations, etc. are borne by the purchaser and the user, and SAITO SEISAKUSHO CO., LTD. is exempt from any responsibilities.

**Warranty:**

- If there is any deficiency from the factory concerning manufacture, please consult with the shop or distributor you bought from. Our company will be responsible for repair. However, any failure or trouble caused by unnecessary disassembly, modification, or other uses than those provided in the instruction manual is not subject to warranty.
- Ignition system is subject to the warranty only for initial failure. Once the system has been activated successfully, it will no longer be subject to warranty.

All specifications and models are subject to change without notice.

**SAITO** SAITO SEISAKUSHO, CO., LTD. www.saito-mfg.com

22-7, 3-chome, Tokagi, Ichikawa-shi, Chiba prefecture 272-0024, Japan Phone: 047-378-4156 FAX: 047-378-4155

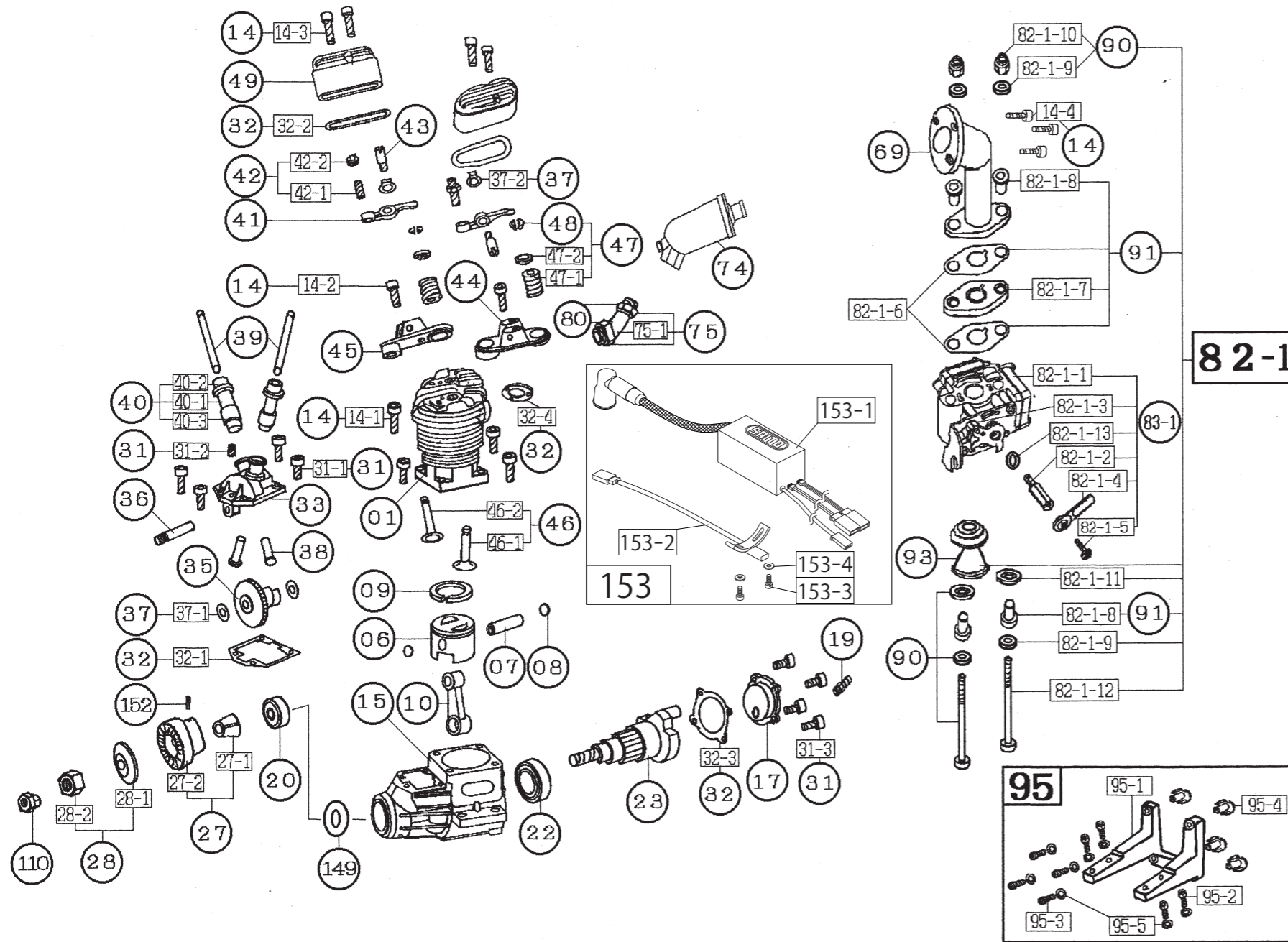

**FG-40 Parts List**

No.	Item	Qty	No.	Item	Qty
01	Cylinder	1	43	Rocker arm pin	2
06	Piston	1	44	Rocker arm bracket (left)	1
07	Piston pin	1	45	Rocker arm bracket (right)	1
08	Piston pin retainer	2	46	Valve set (In & Ex)	1set
09	Piston ring	1	47	Valve spring & Keeper & Retainer	2ea.
10	Connecting rod	1	47-1,-2,48		
14	Cylinder screw set	1set	48	Valve retainer	2
	14-1,-2,-3,-4		49	Rocker arm cover	2
15	Crankcase	1	69	Intake manifold (Intake pipe)	1
17	Rear cover	1	74	Muffler	1
19	Breather nipple	1	75	Muffler manifold set	1set
20	Front ball bearing	1	75-1,80		
22	Rear ball bearing	1	80	Muffler nut	2
23	Crankshaft	1	82-1	Carburetor complete	1set
27	Taper collet & drive flange	1ea.	83-1	Carburetor body assembly	1set
	27-1,-2			82-1-1,-1-2,-1-3,-1-4,-1-5,-1-13	
28	Prop washer & Nut	1ea.	90	Carburetor screw & spring set	1set
	28-1,-2			82-1-9,-1-10,-1-11,-1-12	
31	Crankcase screw set	1set	91	Carburetor gasket set	1set
	31-1,-2,-3			82-1-6,-1-7,-1-8	
32	Engine gasket set	1set	93	Intake velocity stack (air funnel)	1
	32-1,-2,-3,-4,-5,-6,-8		95	Engine mount set	1set
33	Cam gear housing	1		95-1,-2,-3,-4,-5	
35	Cam gear	1	110	Anti loosening nut	1
36	Cam gear shaft	1	120	Spark plug (CM-6)	1
37	Steel washer set	1set	149	Oil slinger	1
38	Tappet	2	152	Screw pin (For drive flange setting)	1
39	Pushrod	2	153	Electronic ignition system	1set
40	Pushrod cover & Rubber seal	2ea.		153-1,-2,-3,-4,-5	
41	Rocker arm	2			
42	Rocker arm screw & nut	2ea.			
	41-1,-2				

