

Radio control model / Flugmodell

U.S NAVY

F-8F

BEARCAT

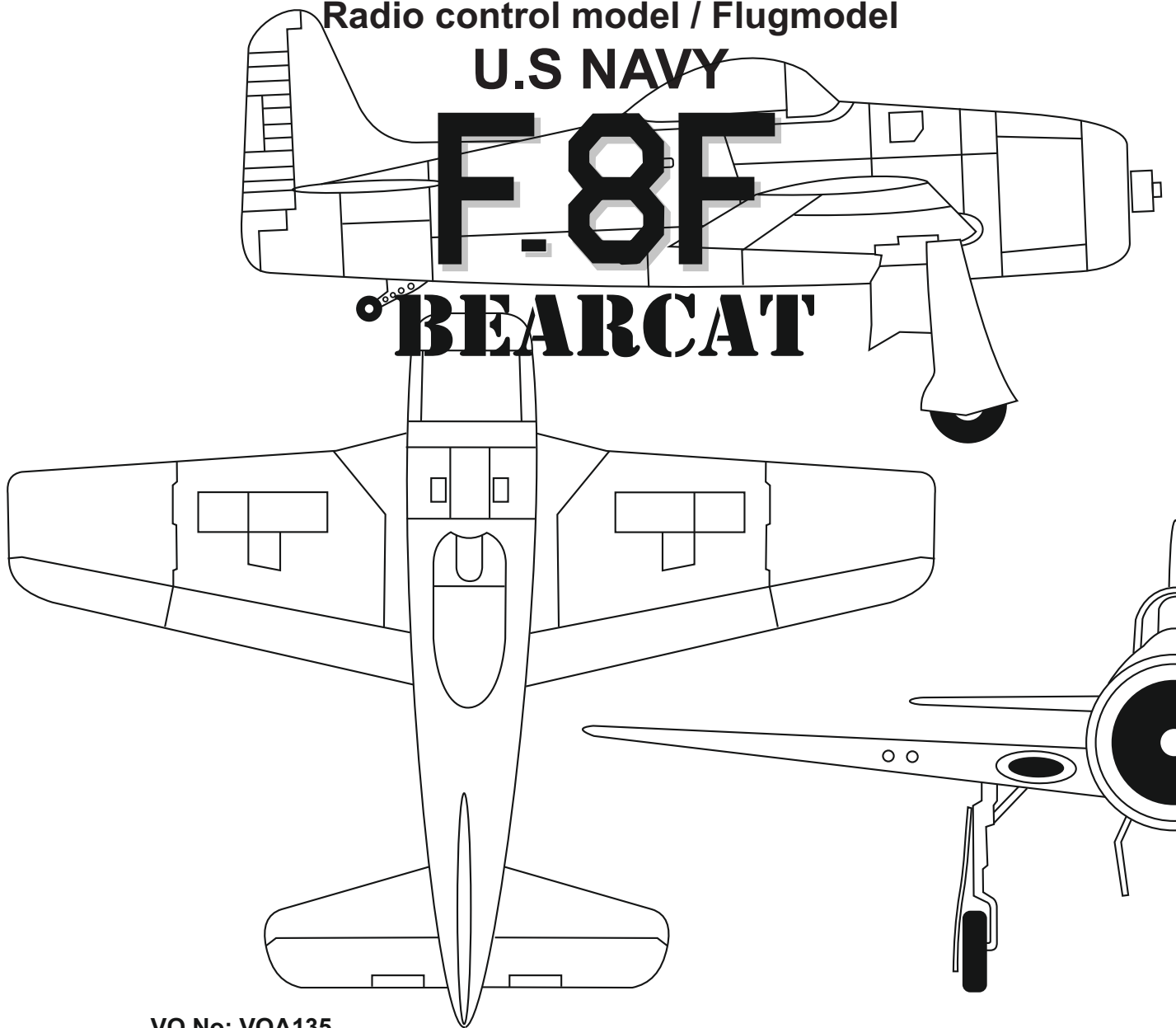

VQ No: VQA135

ALL Balsa, PLYWOOD CONSTRUCTION AND ALMOST READY TO FLY

## Instruction manual / Montageanleitung

### SPECIFICATIONS

Wingspan:.....2020mm (79.5in)  
Length:.....1540mm (60.6 in)  
Electric Motor:.....See next pager  
Gas Engine:.....4T 40cc / 2T 30cc  
RTF Weight: 7.1Kg / 15.7lbs (Will vary with  
Equipment Used).  
Radio:.....8-9 Channel / 8-9 Servos  
Function: Ailerons-Elevator-Rudder-Throttle  
Flaps-Optional Retractable Landing Gear.

### TECHNISCHE DATEN

Spannweite:.....2020mm  
Länge:.....1540mm  
Elektroantrieb.....(siehe nächste Seite)  
Verbrennerantrieb:.....26-30cc  
Fluggewicht:.....7.1Kg  
Fernsteuerung.....8-9 Kanal / 8-9 Servos



**WARNING!** This radio controlled model is NOT a toy. If modified or flown carelessly it could go out of control and cause serious human injury or property damage. Before flying your airplane, ensure the air field is spacious enough. Always fly it outdoors in safe areas and seek professional advice if you are unexperienced.

**ACHTUNG!** Dieses ferngesteuerte Modell ist KEIN Spielzeug! Es ist für fortgeschrittene Modellflugpiloten bestimmt, die ausreichende Erfahrung im Umgang mit derartigen Modellen besitzen. Bei unsachgemäßer Verwendung kann hoher Personen- und/oder Sachschaden entstehen. Fragen Sie in einem Modellbauverein in Ihrer Nähe um professionelle Unterstützung, wenn Sie Hilfe im Bau und Betrieb benötigen. Der Zusammenbau dieses Modells ist durch die vielen Abbildungen selbsterklärend und ist für fortgeschrittene, erfahrene Modellbauer bestimmt.

## REQUIRED FOR OPERATION (Purchase separately)

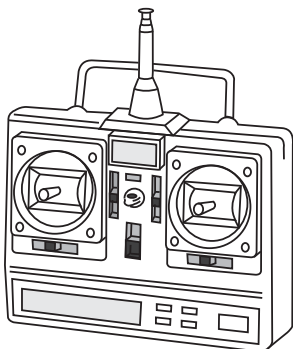

Minimum 8-9 channels radio

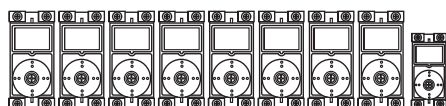

8 standard servos and 1 mini servo (for gas engine).  
 .Motor control x1(for GP) .Elevator x2  
 .Rudder x1. Aileron x2. Flap x2  
 .Gear door x1

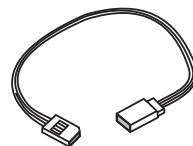

Extension cord for aileron servos: 80cm(x2)  
 Extension cord for flap servos: 50cm(x2)  
 Extension cord for retract servos: 50cm(x2)  
 Extension cord for Rx battery pack: 30cm(x1)  
 Extension cord for gear door servo: 30cm(x1)

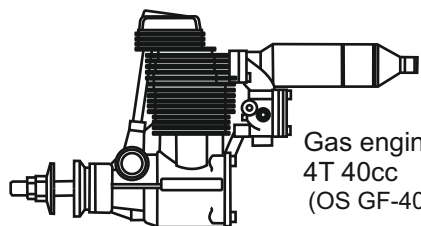

Gas engine:  
4T 40cc  
(OS GF-40)

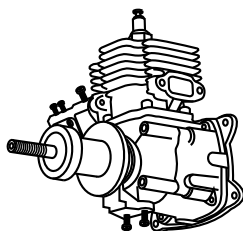

Gas engine:  
2T 26-30cc

Electric retract-Struts  
VQ-ARE24S

Struts: VQ-AS11

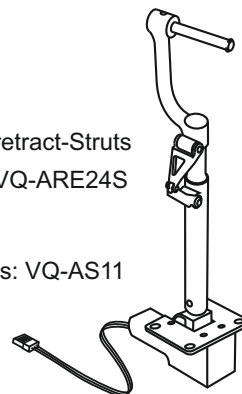

## GLUE (Purchase separately)



Silicon sealer

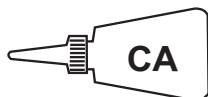

Cyanoacrylate Glue (thin type)



Epoxy Glue  
(5 minute type)

## TOLLS REQUIRED (Purchase separately)

Hobby knife



Phillip screw driver

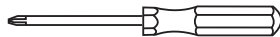

Hex Wrench



Needle nose Pliers

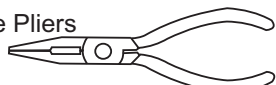

Scissors

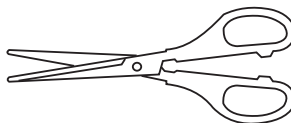

Awl



Sander



Wire Cutters

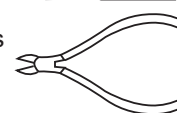

Masking tape - Straight Edged Ruler - Pen or pencil - Drill and Assorted Drill Bits

If exposed to direct sunlight and/or heat, wrinkles can appear. Storing the model in a cool place will let the wrinkles disappear. Otherwise, remove wrinkles in covering film with a hair dryer, starting with low temperature. You can fix the corners by using a hot iron.

Bei Sonneneinstrahlung und/oder Wärme kann die Folie erschlaffen bzw. Falten entstehen. Verwenden Sie ein Warmluftgebläse (Haartrockner) um evtl. Falten aus der Folie zu bekommen. Die Kanten können Sie mit einem Bügeleisen behandeln. Nicht zuviel Hitze anwenden !

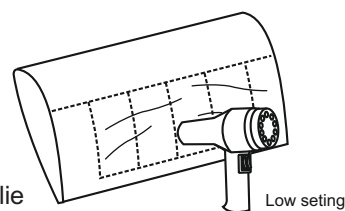

Symbols used throughout this instruction manual, comprise:



Drill holes using the stated size of drill (in this case 1.5 mm)



Take particular care here



Hatched-in areas: remove covering film carefully



Check during assembly that these parts move freely, without binding



Use epoxy glue



Apply cyano glue



Assemble left and right sides the same way.



Not included. These parts must be purchased separately



Löcher bohren mit dem angegebenen Bohrer (hier 1,5 mm)



Hier besonders aufpassen



Schraffierte Stellen, Bespannfolie vorsichtig entfernen



Während des Zusammenbaus immer prüfen, ob sich die Teile auch reibungslos bewegen lassen



Epoxy-Klebstoff verwenden



Sekundenkleber auftragen



Linke und rechte Seite wird gleichermaßen zusammengebaut



Nicht enthalten. Teile müssen separat gekauft werden.

Read through the manual before you begin, so you will have an overall idea of what to do.

## CONVERSION TABLE

1.0mm = 3/64"	3.0mm = 1/8"	10mm = 13/32"	25mm = 1"
1.5mm = 1/16"	4.0mm = 5/32"	12mm = 15/32"	30mm = 1-3/16"
2.0mm = 5/64"	5.0mm = 13/64"	15mm = 19/32"	45mm = 1-51/64"
2.5mm = 3/32"	6.0mm = 15/64"	20mm = 51/64"	

# SECTION 1- WING: FLAP-AILERON RARE BEAR

- 1-Move the aileron and flap servo hatch out of the wing
- 2-Install the aileron servo to the aileron servo hatch as shown.
- 3-Install the flap servo to the flap servo hatch as shown.

Note: If you use only one channel for both the left and right Flap, in this case, remember to install the left and right flap servo in a same direction.

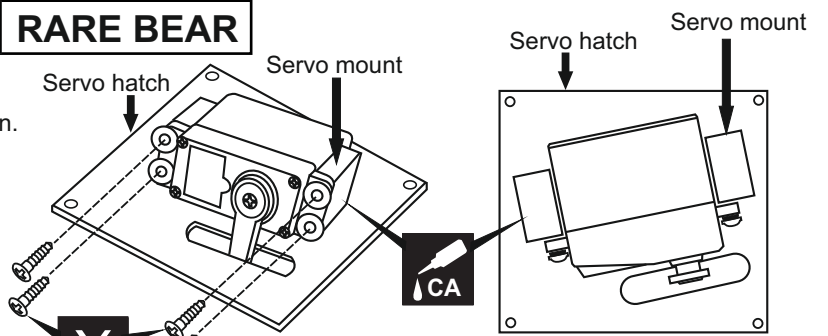

Aileron and flap servo hatch (Top view)

**Securely glue together. If coming off during flight, you lose control of your airplane.**

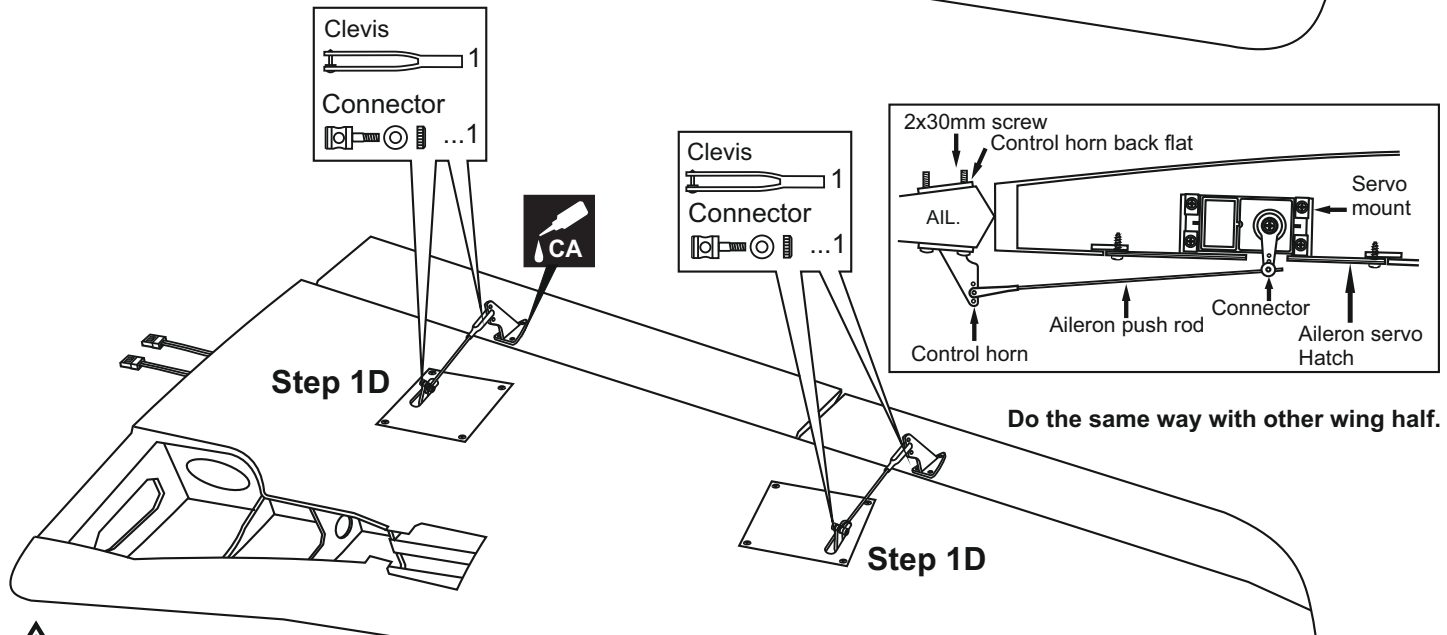
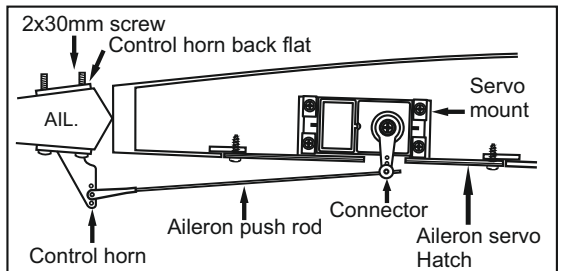
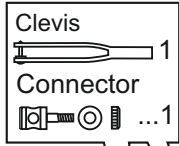
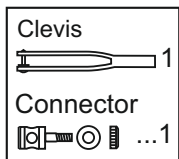
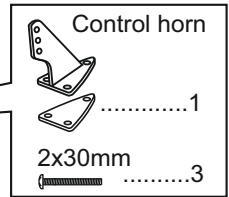
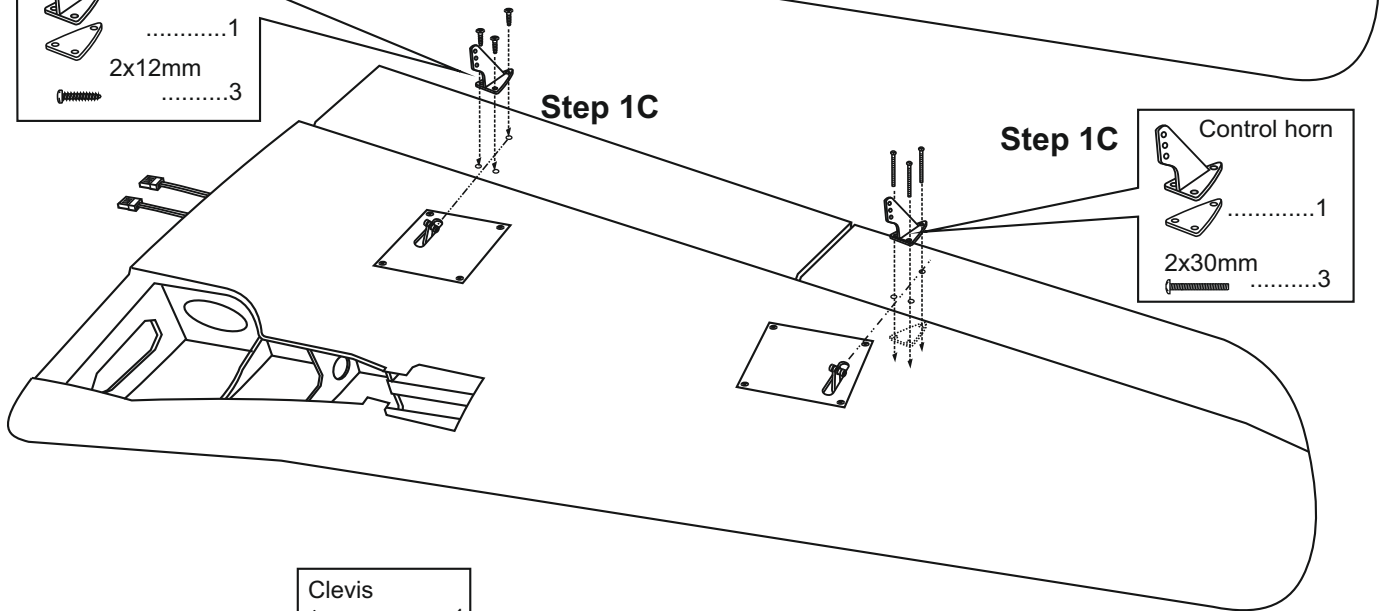
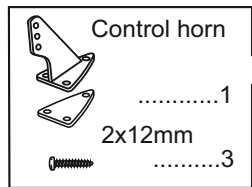
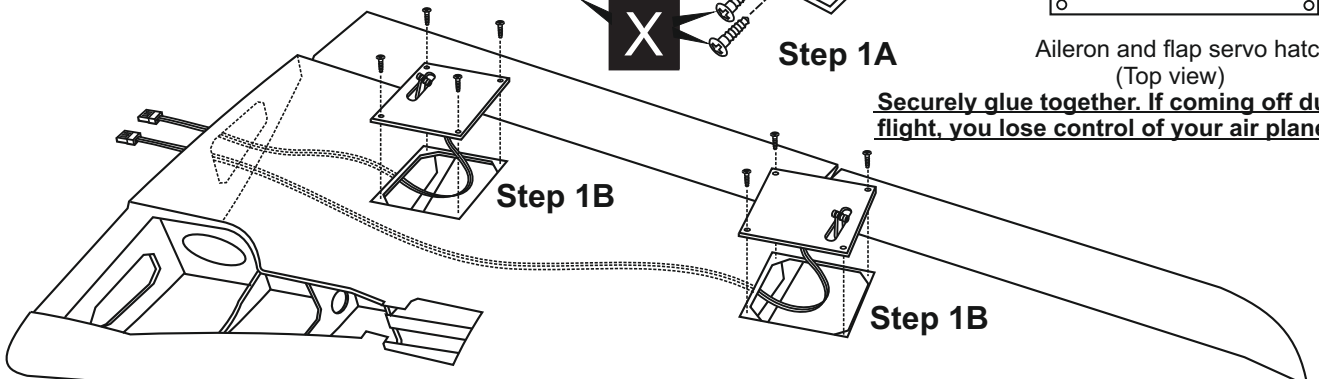



**VERY IMPORTANT**  
Aileron and Flap Safety, See Section 14, Step 14C

If you not make this step, the aialerons and flaps may be comming off when your airplane flying with high speed. You will lose control of your airplane.

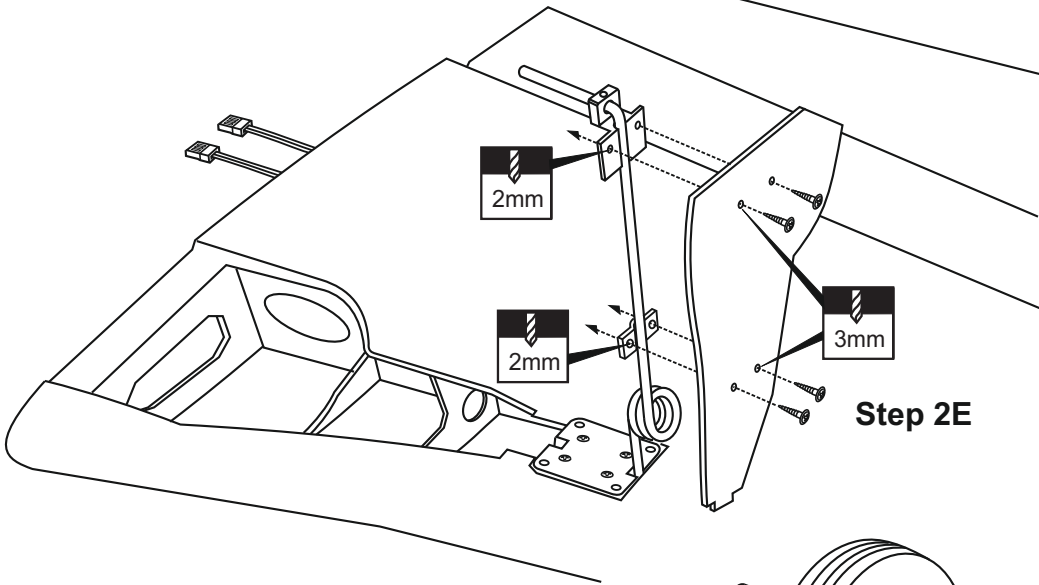
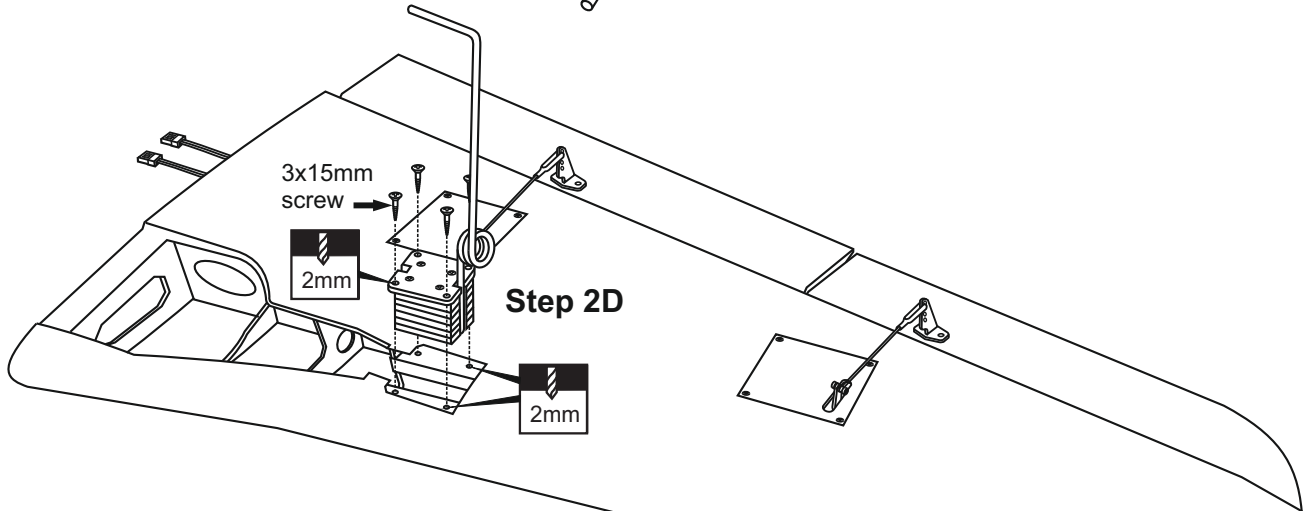
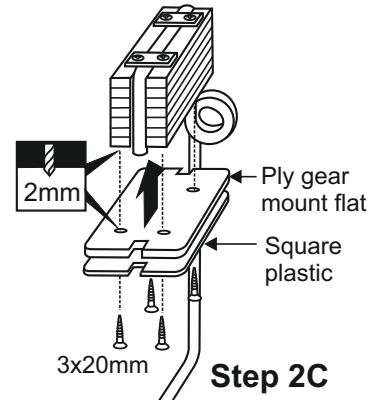
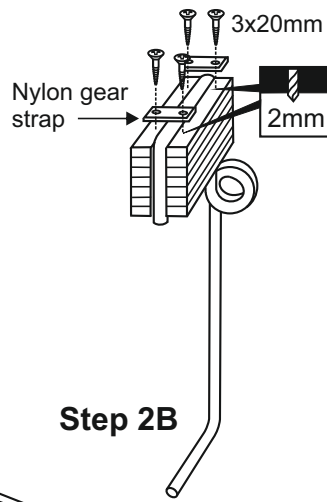
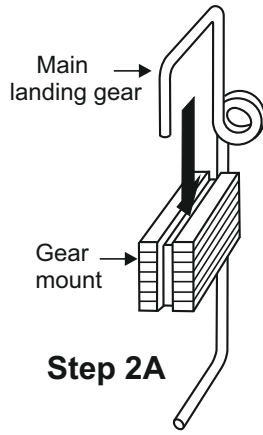
# SECTION 2 - FIXED GEAR

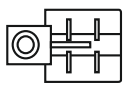
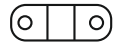

-  ...1
-  ...1
- 3x12mm screw
-  .....2
- 5mm collar
-  .....1

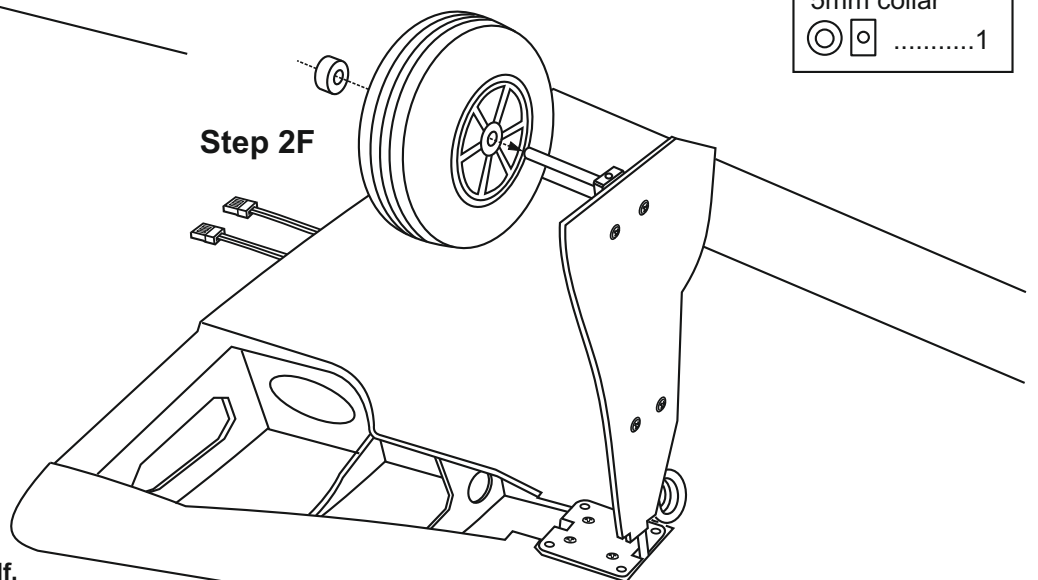

Do the same way with other wing half.

# SECTION 3 - STRUTS

Step 3A

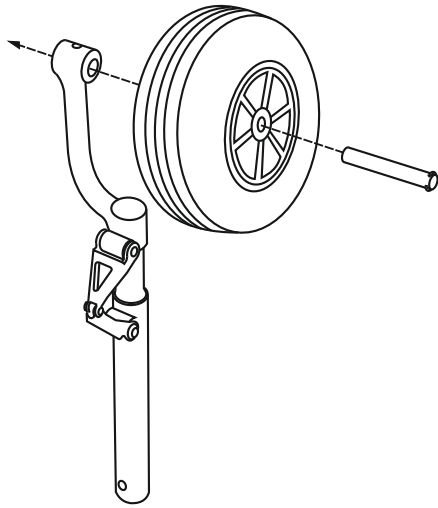

Step 3B

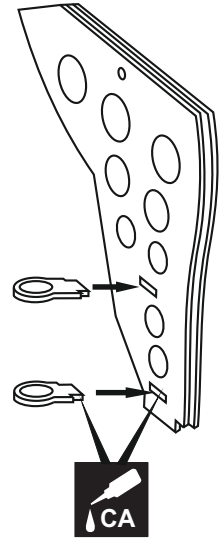

Step 3C

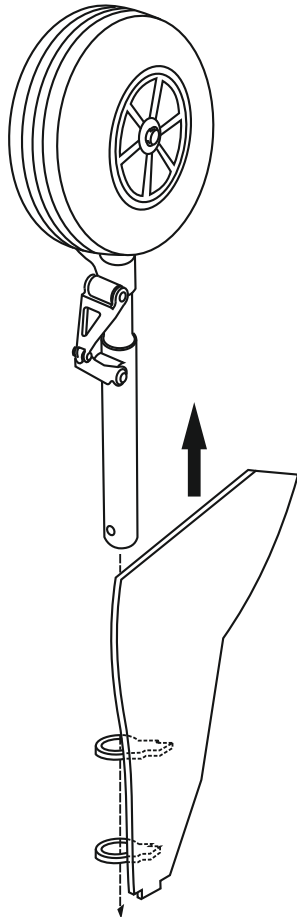

Step 3D

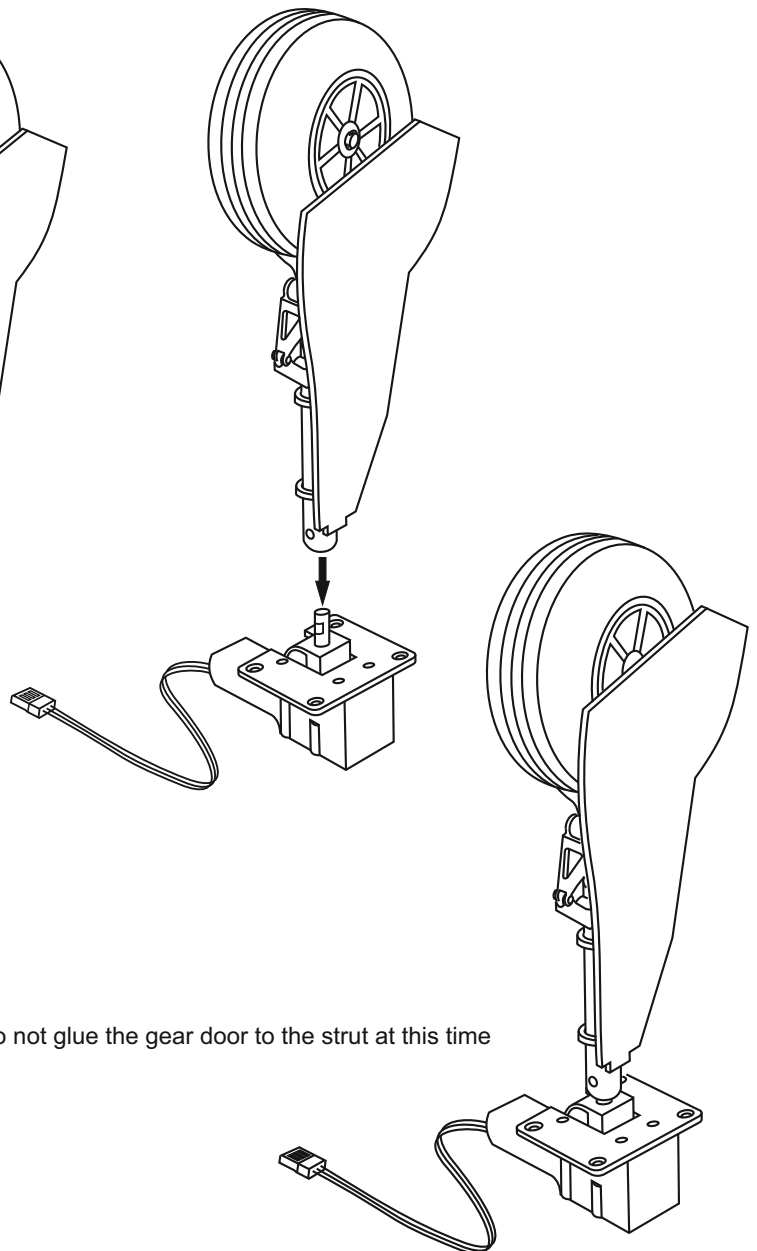

Note: Do not glue the gear door to the strut at this time

## SECTION 4 - RETRACT LANDING GEAR

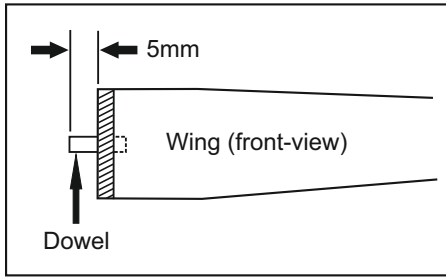

Glue the dowel to the rib root, marking sure that the dowel perpendicular to surface of the rib root.

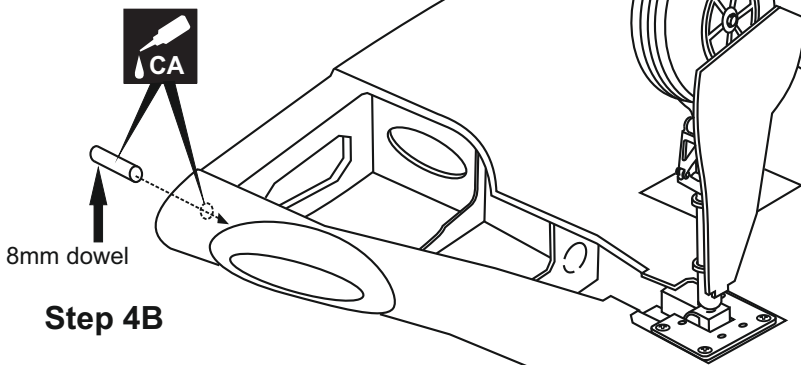
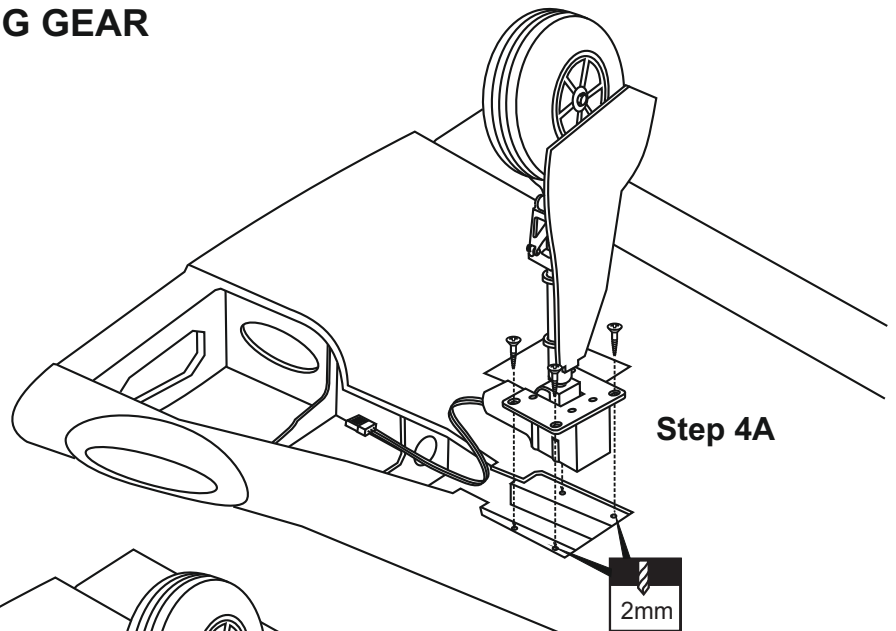

## SECTION 5 - ENGINE

### Step 5A

Fuselage - front view

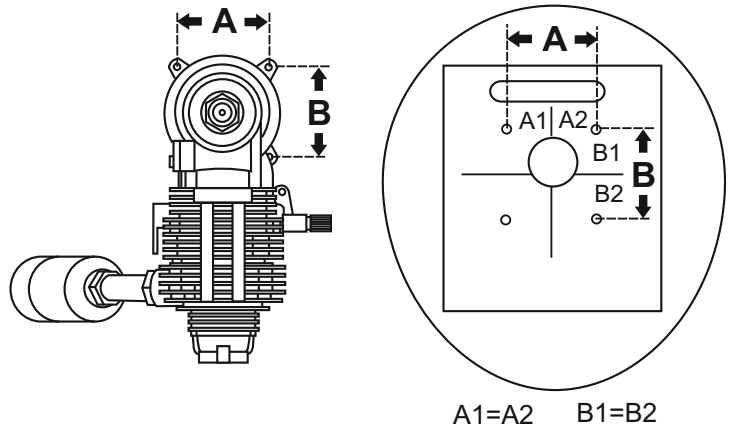

Mark the plywood where the four holes are to be drilled.

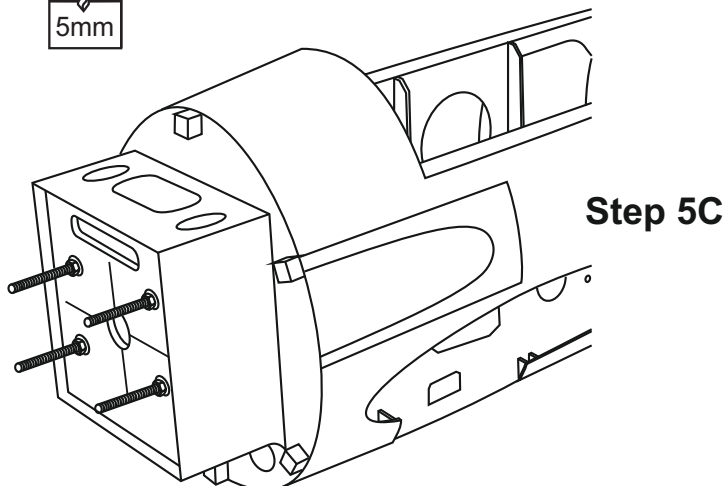
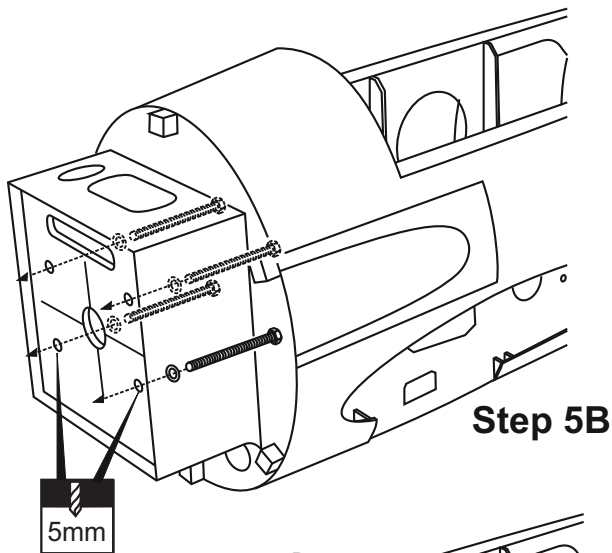

5x80mm screw	.....4
5mm nut	.....12
5mm washer	.....8

## SECTION 5 - ENGINE continued

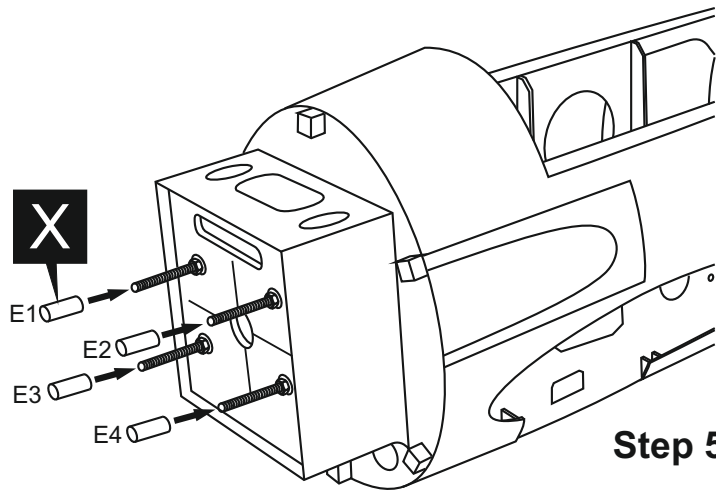

E1=E2=E3=E4 (The long of the aluminum tubes are the same and depend of your engine)

Note: The aluminum tubes for the engine installation not include.

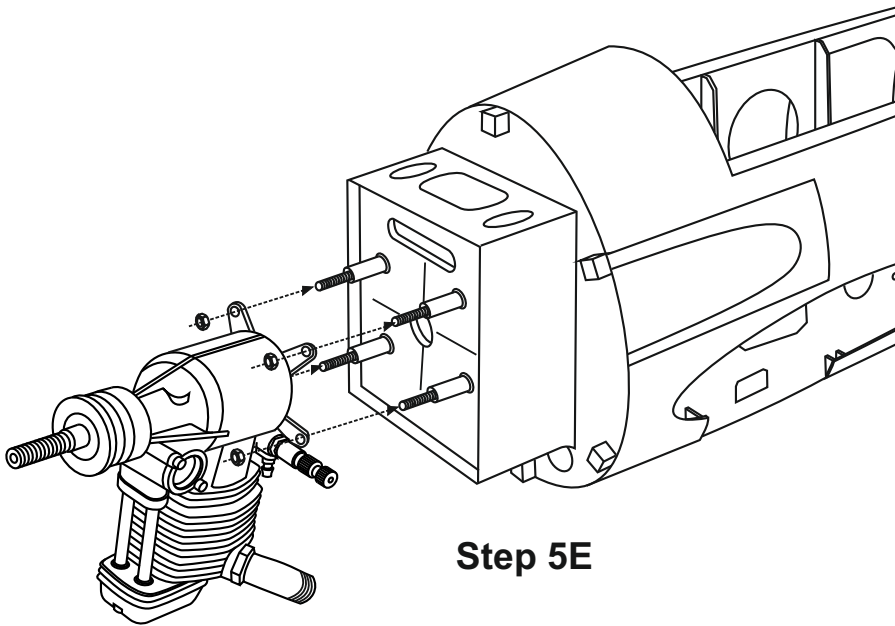

## SECTION 6 - FUEL TANK

Note: secure the 5mm nuts in place using silicon sealer.

**Step 6B**

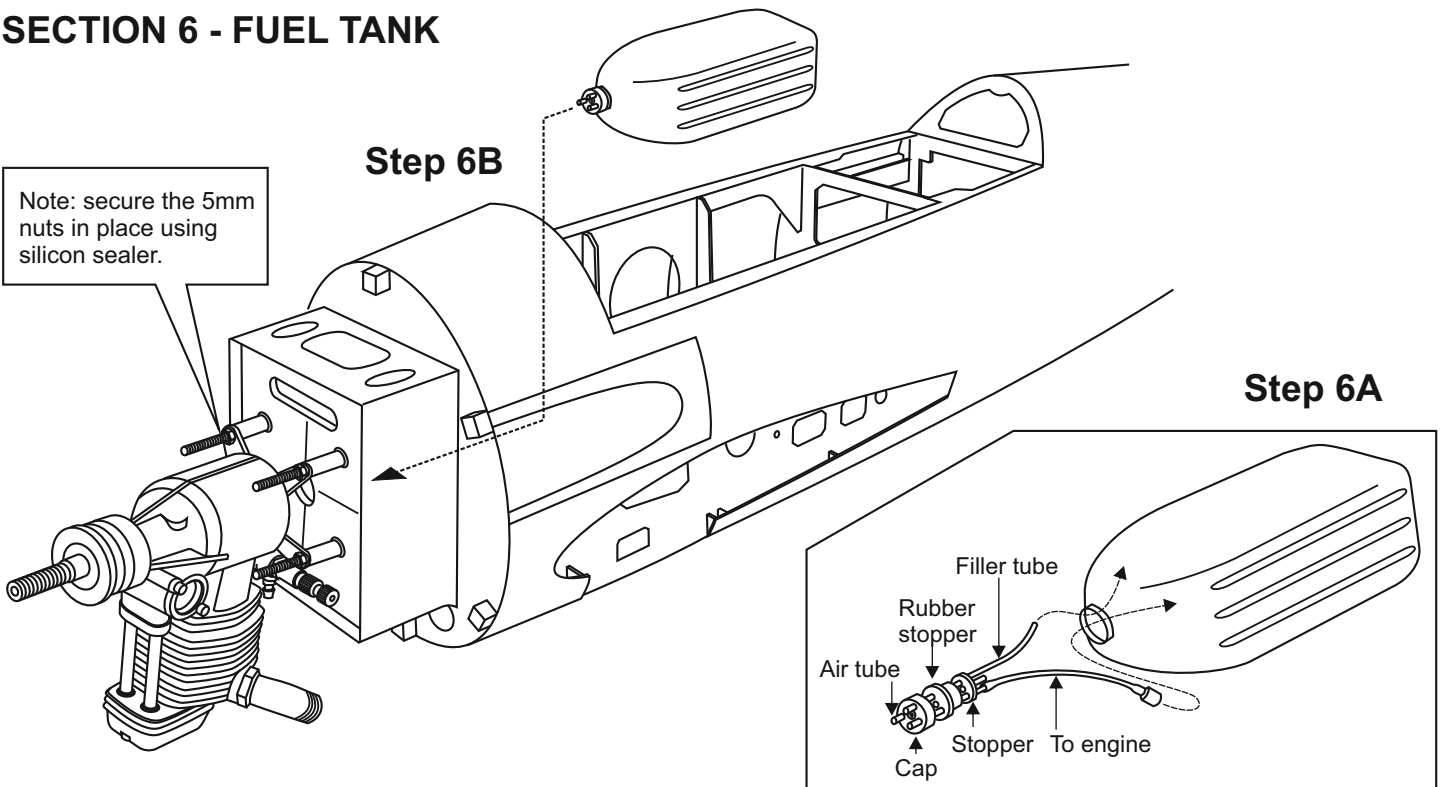

# SECTION 7 - ELECTRIC MOTOR

## Step 7B

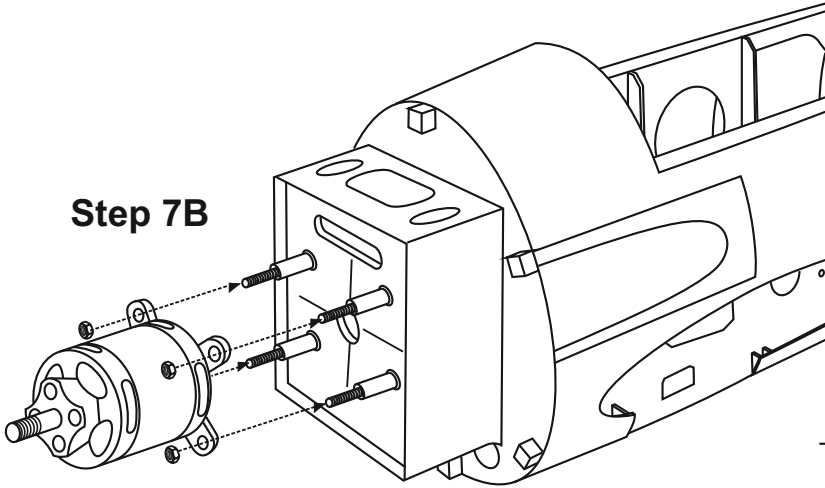

(The long of the aluminum tubes are same and depend of your motor)

Note: The aluminum tubes for the motor installation not include.

## Step 7A

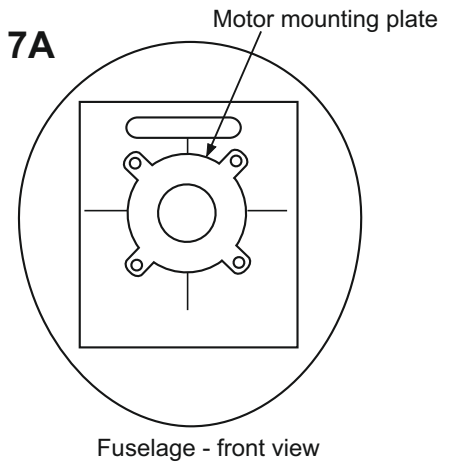

Fuselage - front view

-Using a aluminum motor mounting plate as a template, mark the plywood motor mounting plate where the four holes are to be drilled.

-Remove the aluminum motor mounting plate and drill a 7/32"(5mm) hole through the plywood at each of the four marks marked .

Note: The aluminum motor mounting included with electric motor set.

## Step 7C: gear door servo

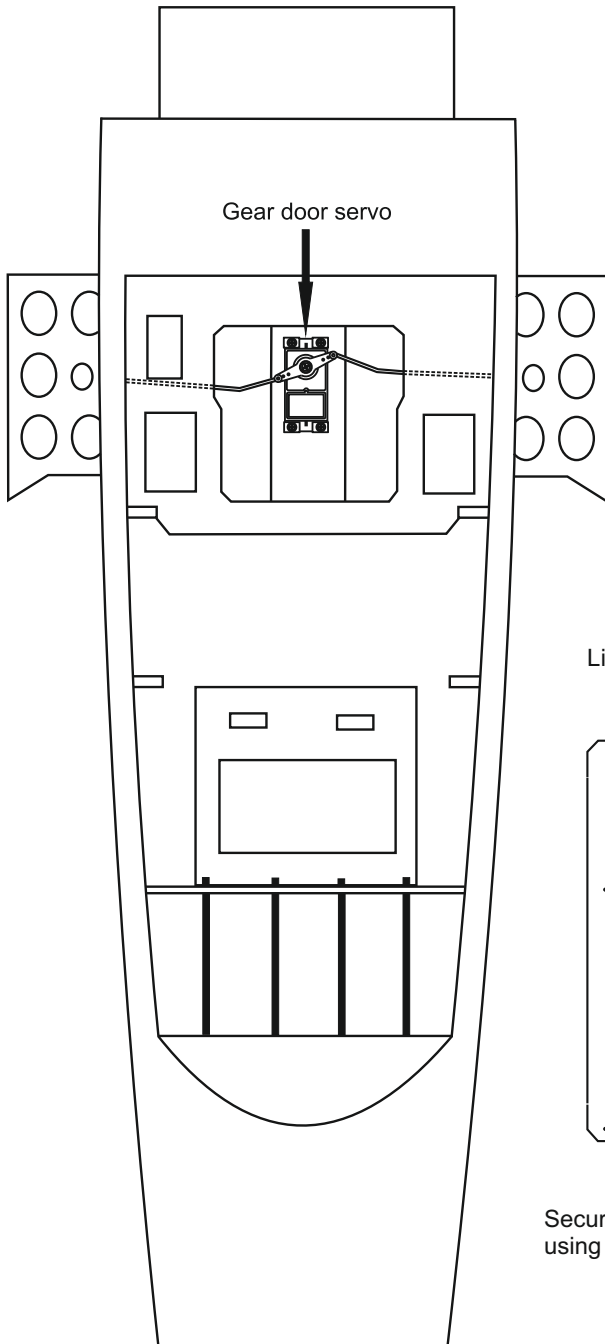

## Step 7D: Battery stand

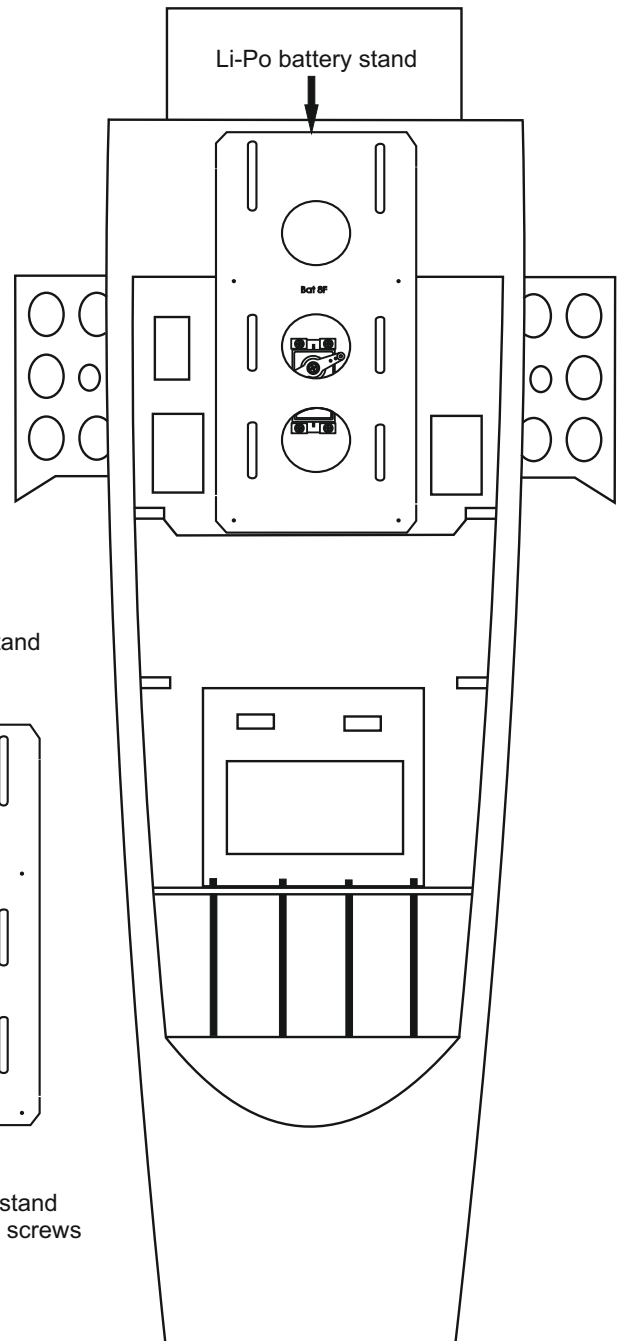

Secure the battery stand using four 3x10mm screws



# SECTION 8 - GEAR DOOR

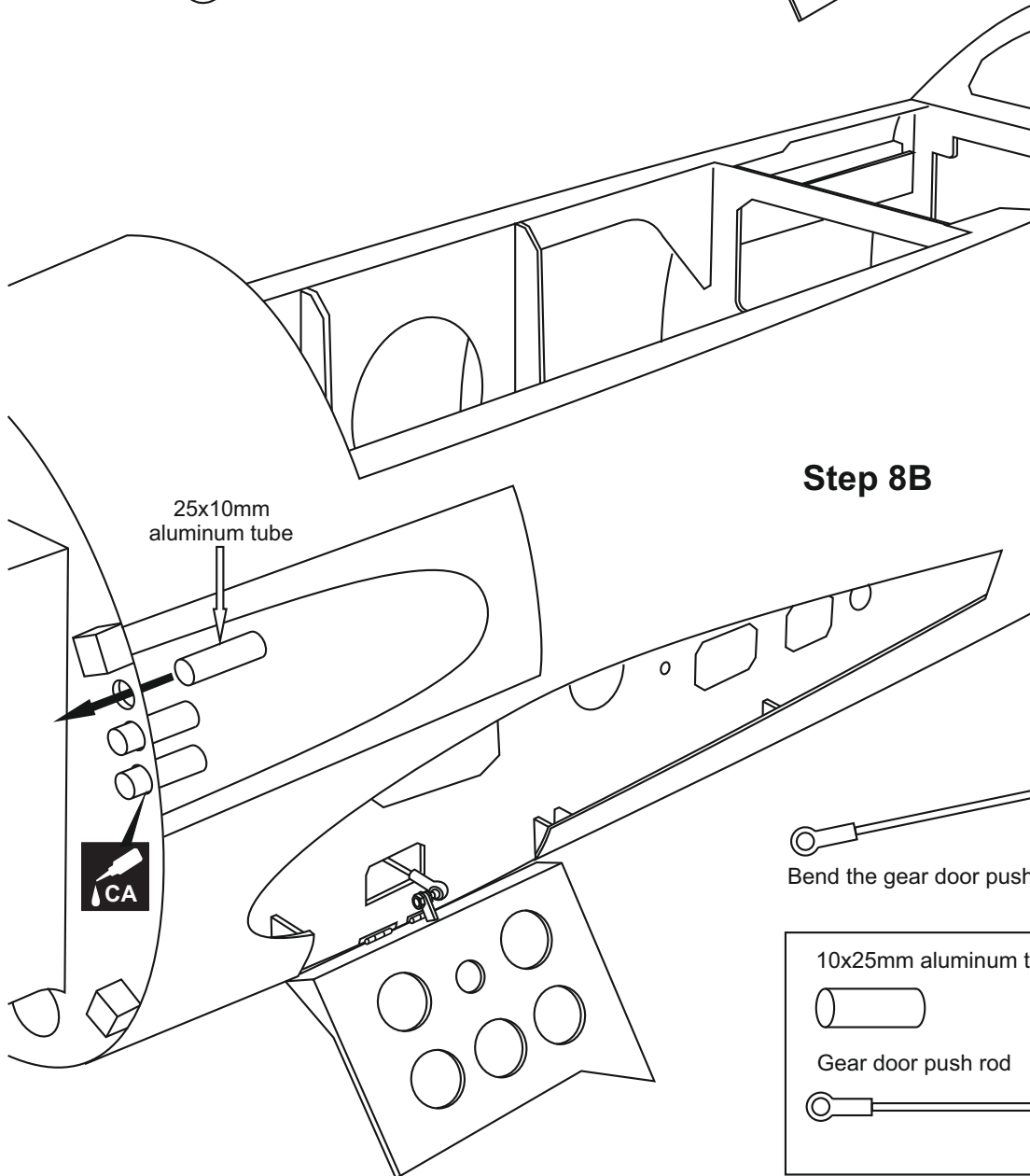
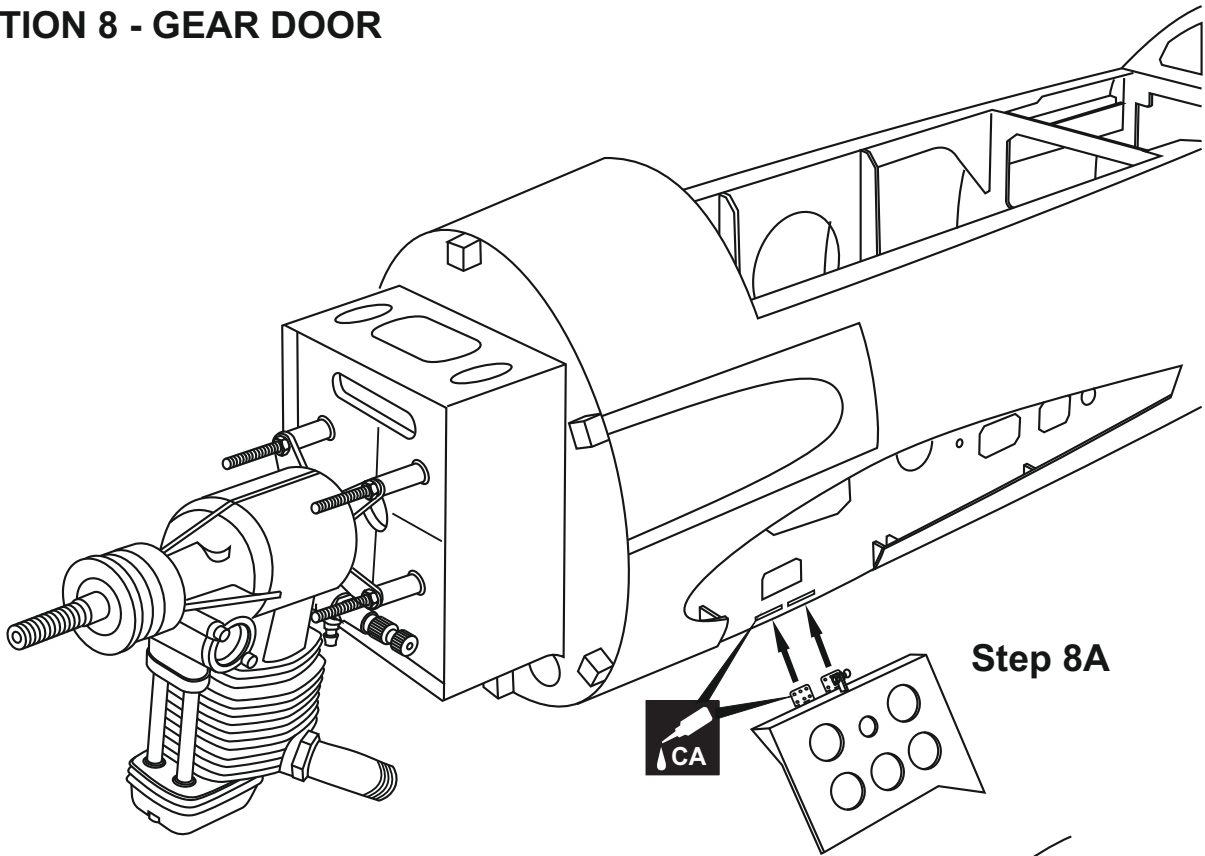

  
 Bend the gear door push rod for smooth work.

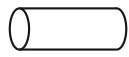
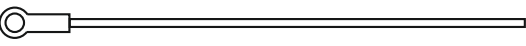
- |  |                        |
|--|------------------------|
|  | .....3 (for each side) |
|  | .....1 (for each side) |

**Do the same way with other side**

# SECTION 9 - JOINING THE WING

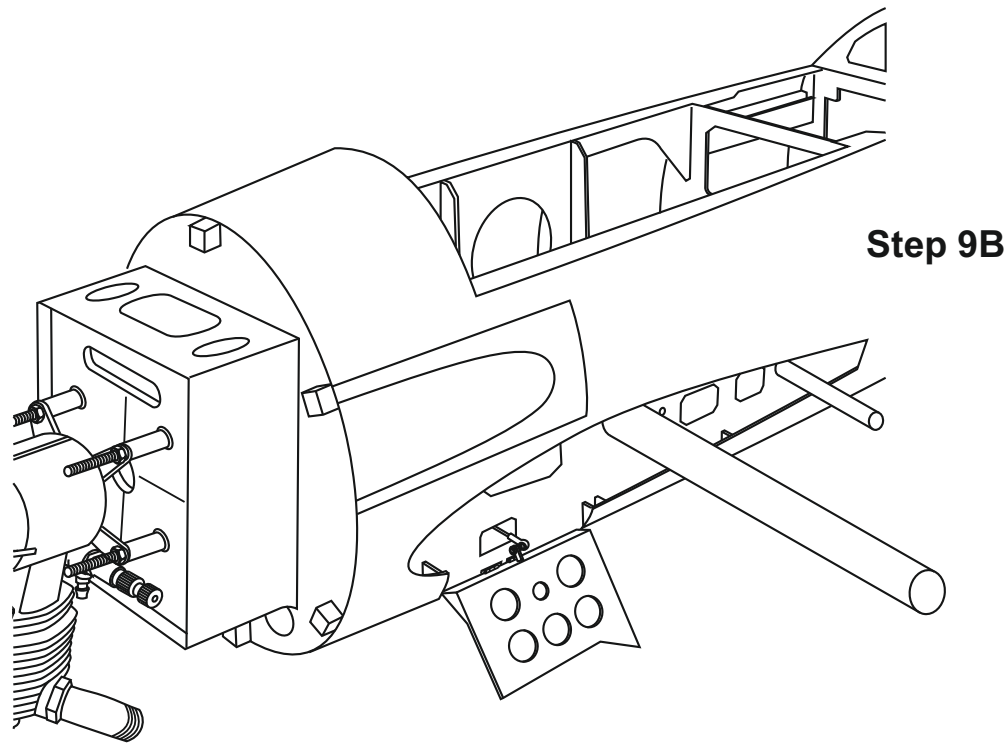
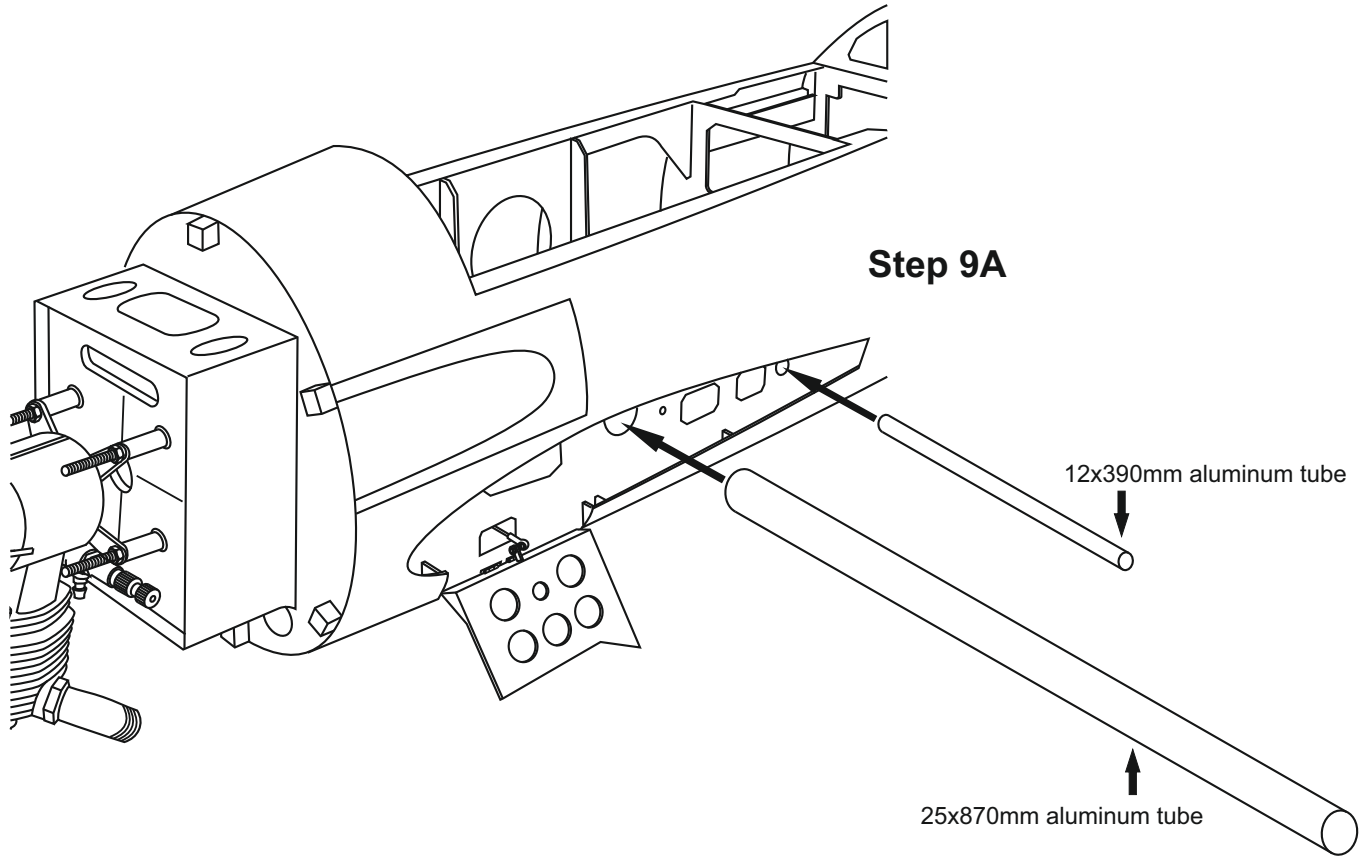

# SECTION 9 - JOINING THE WING continued

## Step 9C

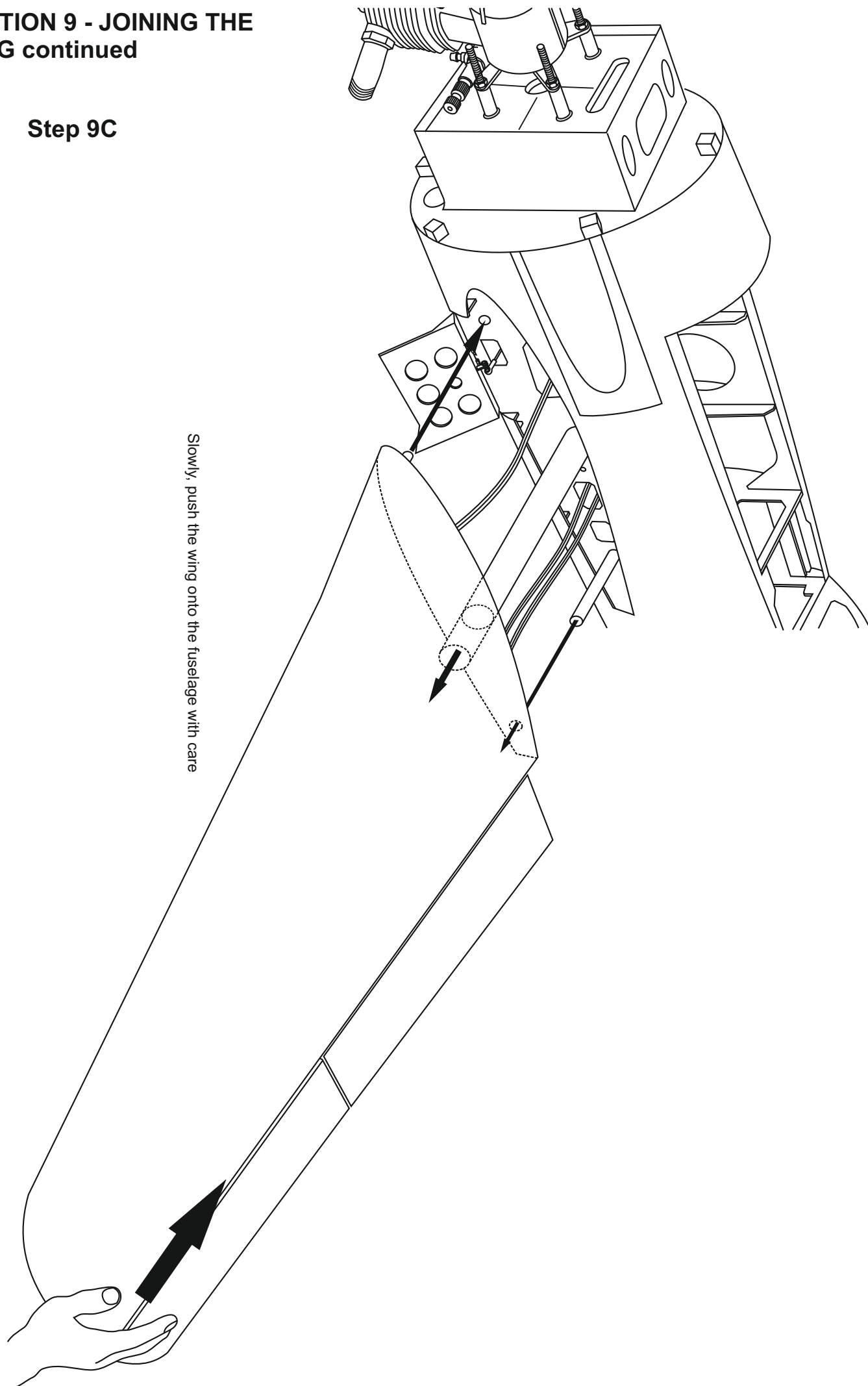

Slowly, push the wing onto the fuselage with care

## SECTION 9 - JOINING THE WING continued

5x20mm screw

 ...1 (for each side)

### Step 9D

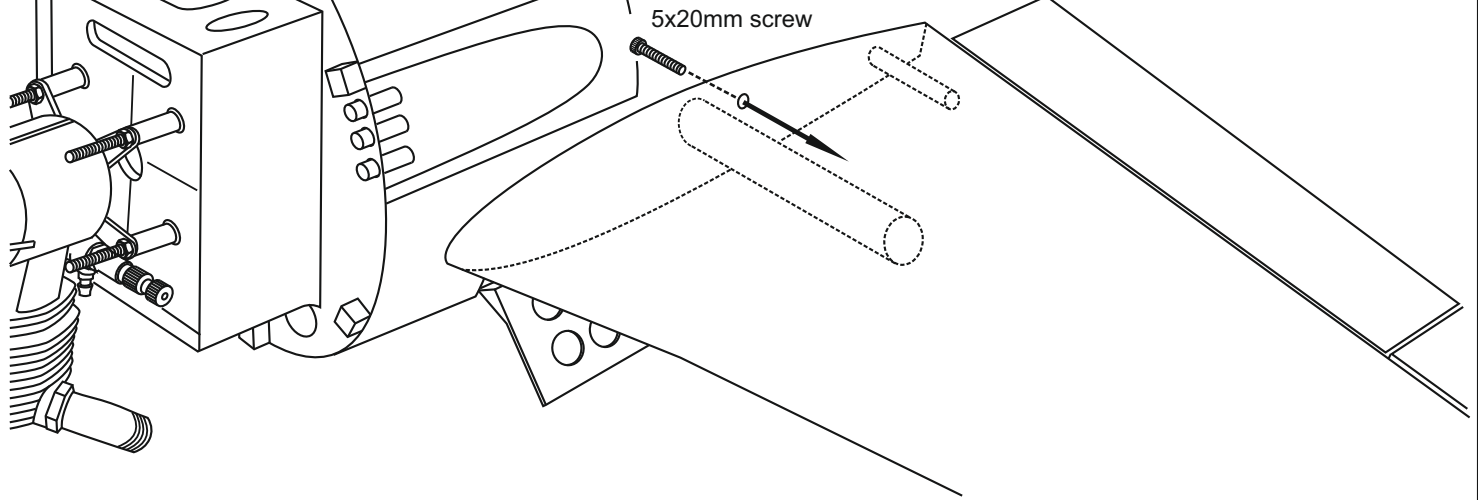

## SECTION 10 - HORIZONTAL STABILIZER

Note: Turn the plastic bolts on the left and right side of the fuselage, full the canopy hatch out of the fuselage first.

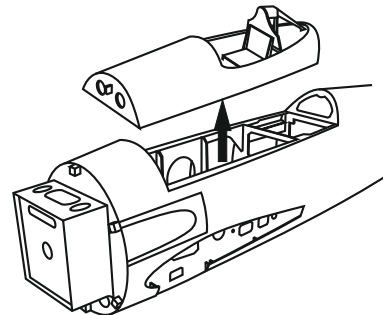
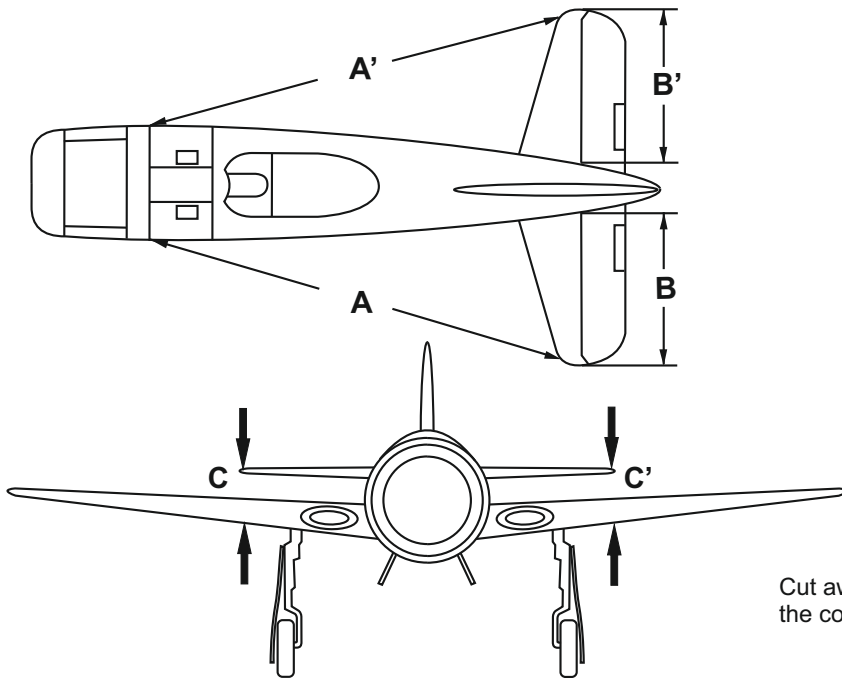

### Step 10A

Cut away only the covering\*



If the fit is overly tight, it may be necessary to lightly sand the hole on the fuselage.

Trial fit the horizontal stabilizer in place on the fuselage. Check the alignment of the horizontal stabilizer. The distance must be equal on both sides ( $A=A'$  and  $B=B'$  and  $C=C'$ ). If not, adjust the stabilizer until the measurements are the same.

**\* WARNING:** When removing any covering from the airframe, please ensure that you secure the cut edge with CA or similar cement. This will ensure the covering remain tight.

## SECTION 10 - HORIZONTAL STABILIZER continued

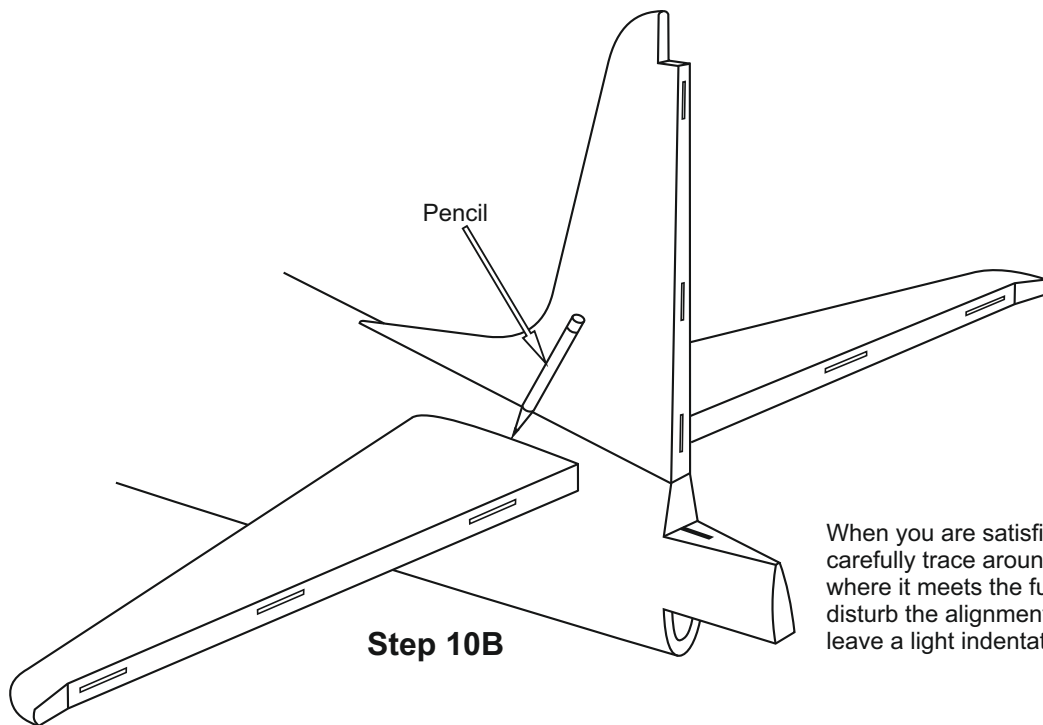

**Step 10B**

When you are satisfied with the alignment, use a pencil to carefully trace around the top and bottom of the stabilizer where it meets the fuselage. Note, it is important not to disturb the alignment of the stabilizer. The pencil should leave a light indentation in the covering.

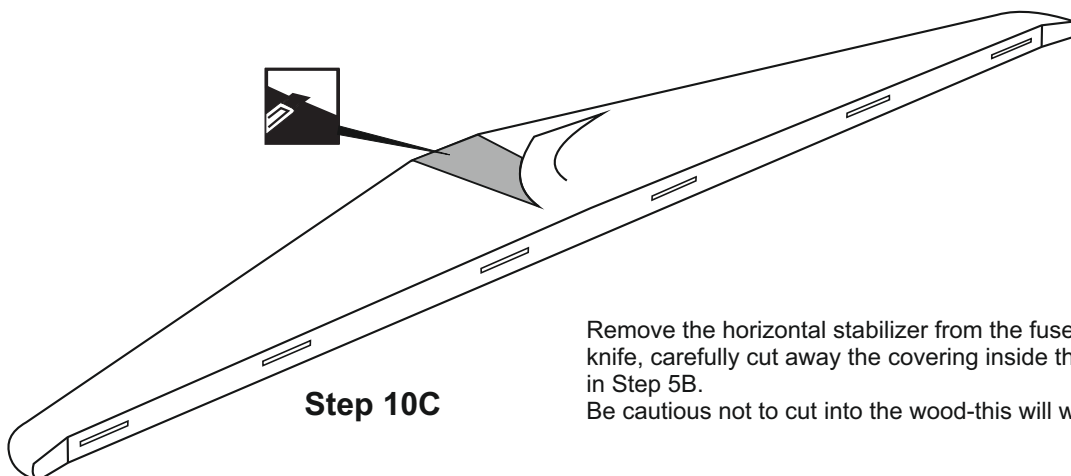

**Step 10C**

Remove the horizontal stabilizer from the fuselage. Using a sharp hobby knife, carefully cut away the covering inside the lines which were marked in Step 5B. Be cautious not to cut into the wood-this will weaken the structure.

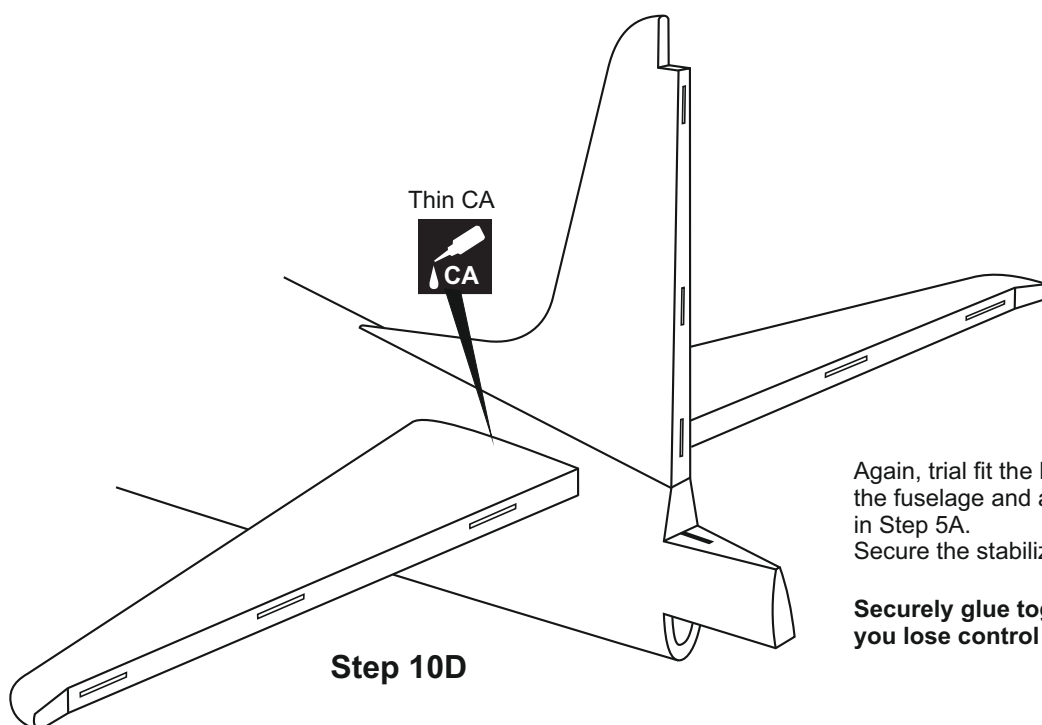

**Step 10D**

Again, trial fit the horizontal stabilizer in place on the fuselage and adjust the alignment as described in Step 5A. Secure the stabilizer in place using the **thin** CA glue.

**Securely glue together. If coming off during flight, you lose control of your air plane.**

# SECTION 14 - ELEVATOR RARE BEAR

Step 14B



5 minutes



Petroleum jelly

Step 14A

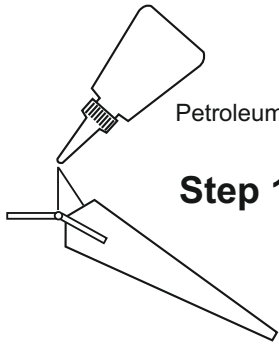

Apply a thin layer of machine oil or petroleum jelly to **only the pivot point and the leading edge** of the elevator.

When satisfied with the and alignment, hinge the elevator to the horizontal stabilizer using 5 minute epoxy. Make sure to apply a thin layer of epoxy to the top and bottom of both hinges and to inside the hinge slots. Repeat the previous procedures to hinge the second elevator to the other side of the horizontal stabilizer.

**NOTE:** You may need to open up the slots so that the hinges are not too difficult to push in.



5 minutes

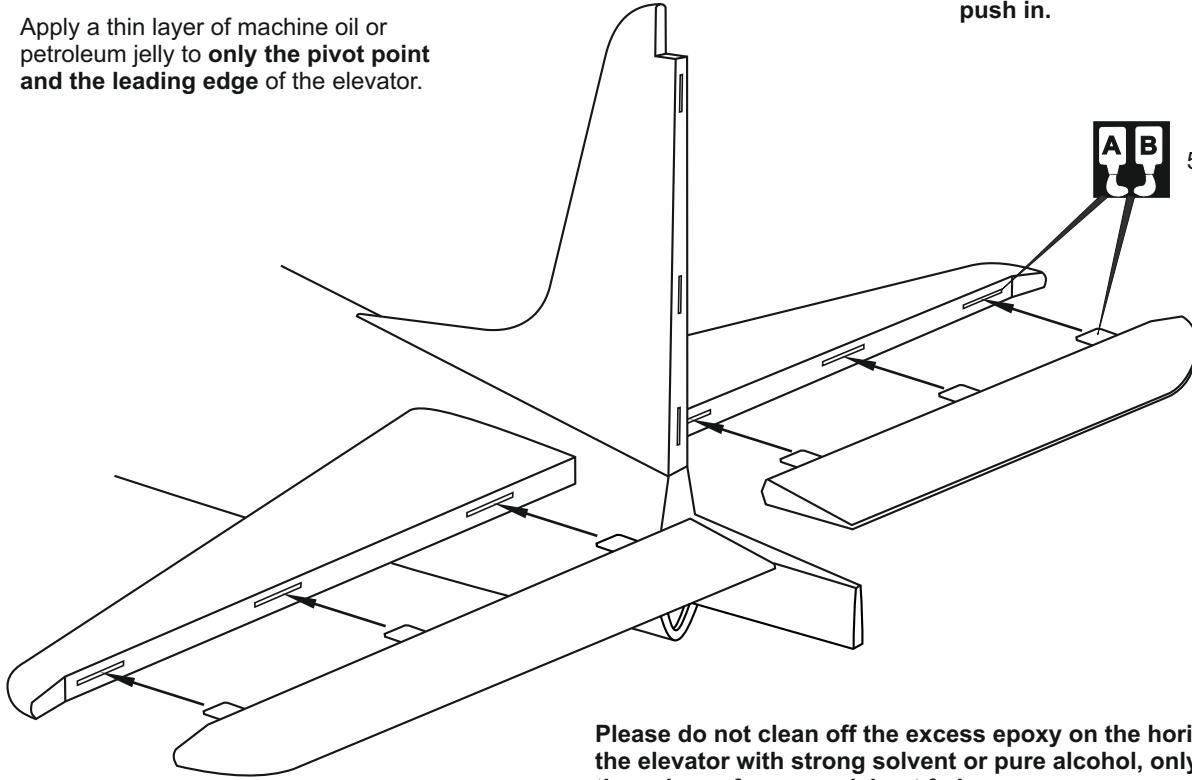

Please do not clean off the excess epoxy on the horizontal stabilizer and the elevator with strong solvent or pure alcohol, only use kerosene to keep the colour of your model not fade.

## Elevator Safety.

Step 14C

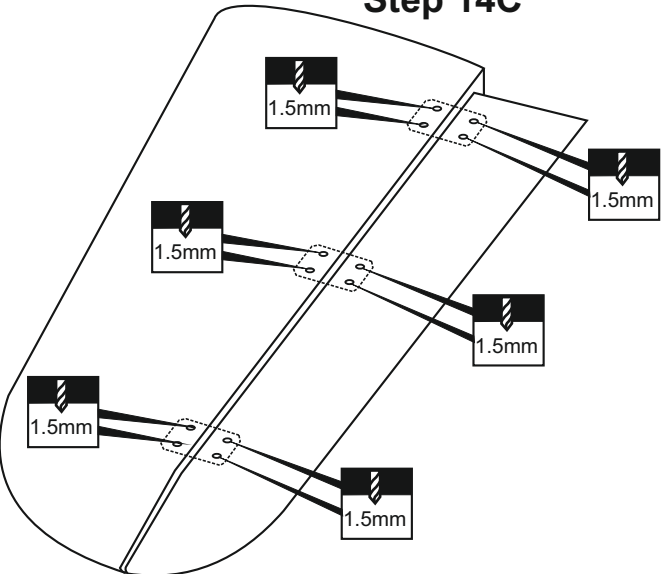

Step 14D

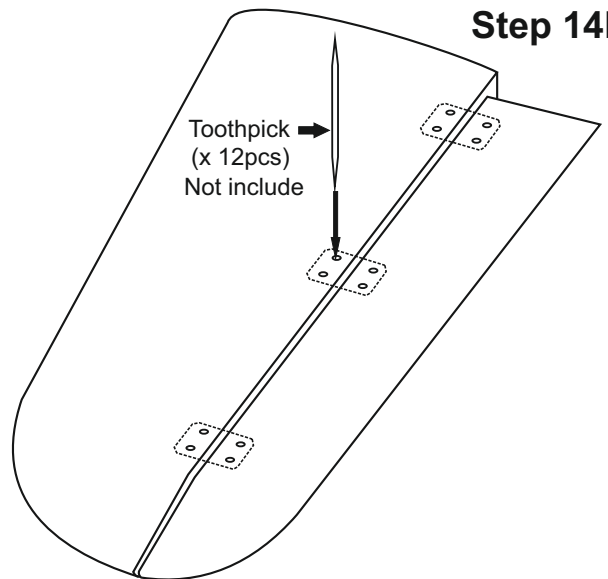

**VERY IMPORTANT**

If you not make this step, the elevator may be coming off when your airplane flying with high speed. You will lose control of your airplane.



Thin CA glue

Step 14E



Toothpick

Cut the excess toothpick and secure it in place using little Thin CA glue.

## SECTION 12 - RUDDER TORQUE ROD BEARING

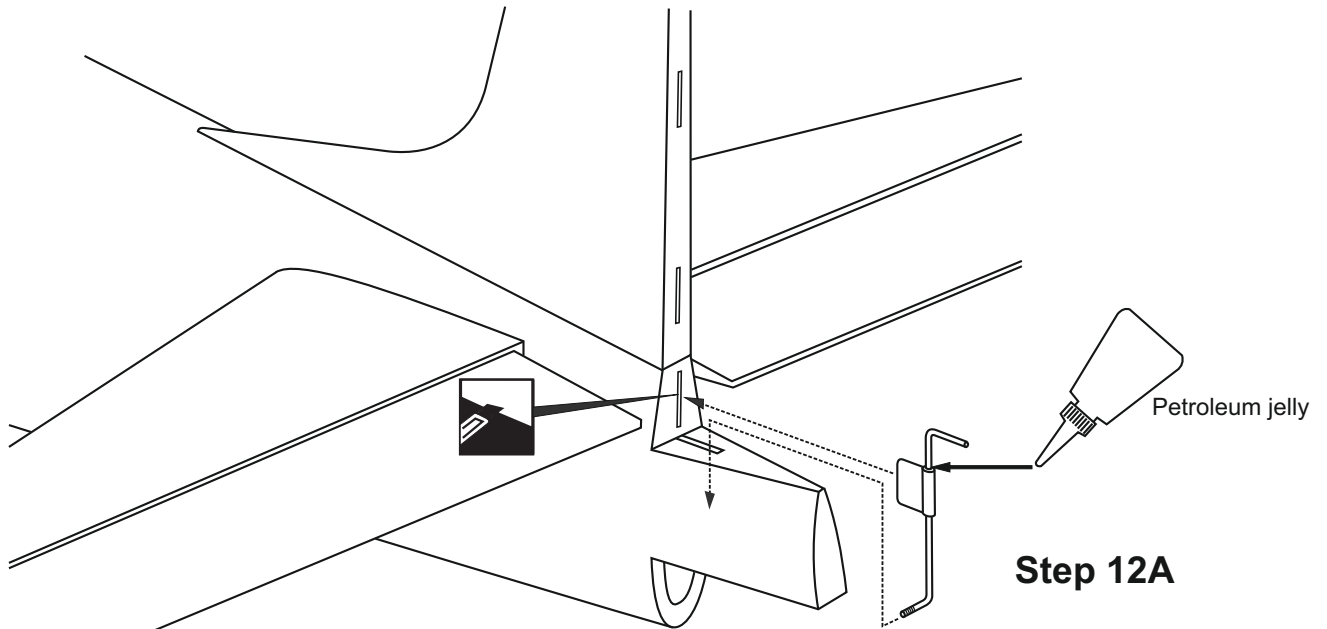

- 1- Cut 22mm (7-8") long slot along the hinge line in the trailing edge of the vertical stabilizer for the rudder torque rod bearing.
- 2- Apply a thin layer of petroleum jelly to only the pivot of the torque rod bearing.

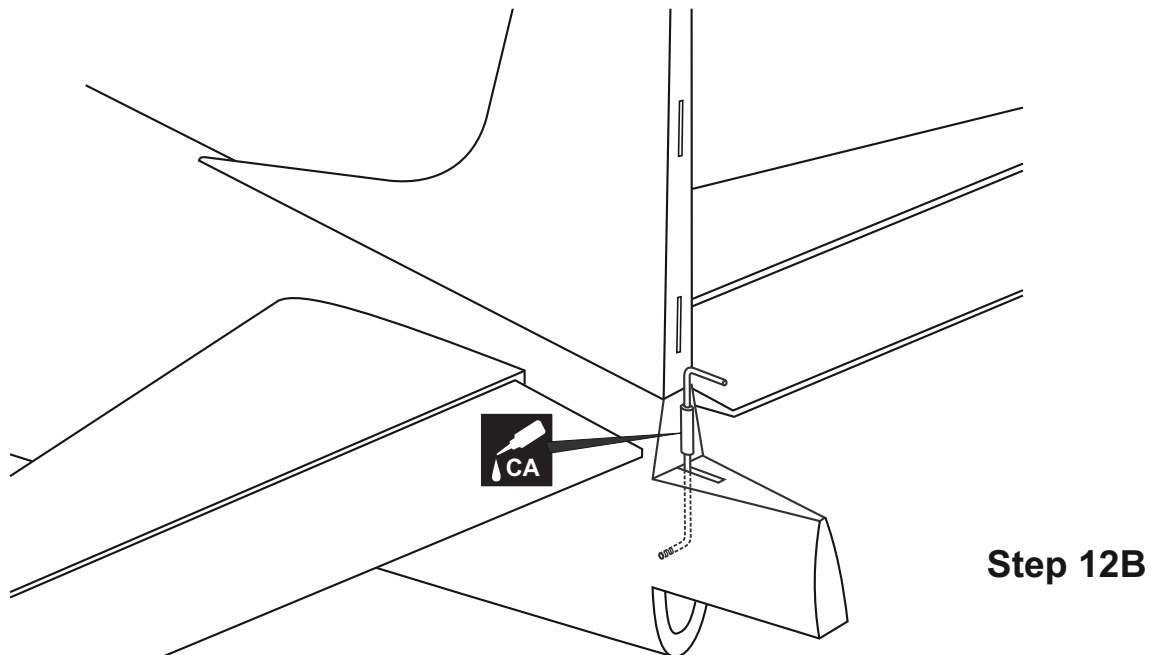

Glue the rudder torque rod bearing into the slot you cut previously in the vertical stabilizer Using the thin CA glue.

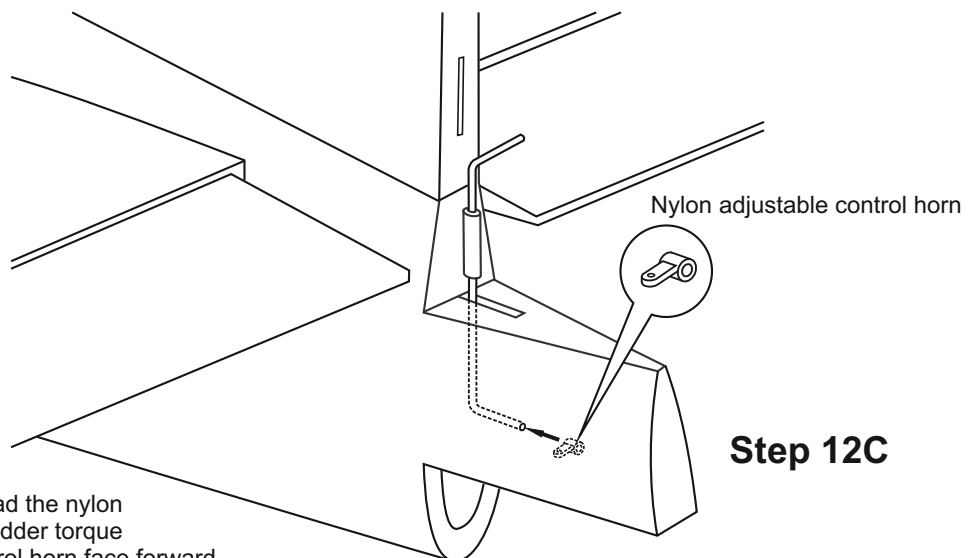

Turn the rudder torque rod bearing, Thread the nylon adjustable control horn onto the end of rudder torque rod, making sure that the adjustable control horn face forward.

## SECTION 13 - RUDDER

Without using glue yet, push the rudder and its hinges into the hinge slots in the trailing edge of the vertical stabilizer. There should be a minimal hinge gap and the end of the rudder should not rub against the vertical stabilizer.

When satisfied with the alignment, mark the mounting hole position, where the rudder torque rod meets the rudder with a pencil.

**NOTE:** You may need to open up the slots so that the hinges are not too difficult to push in.

### Step 13A

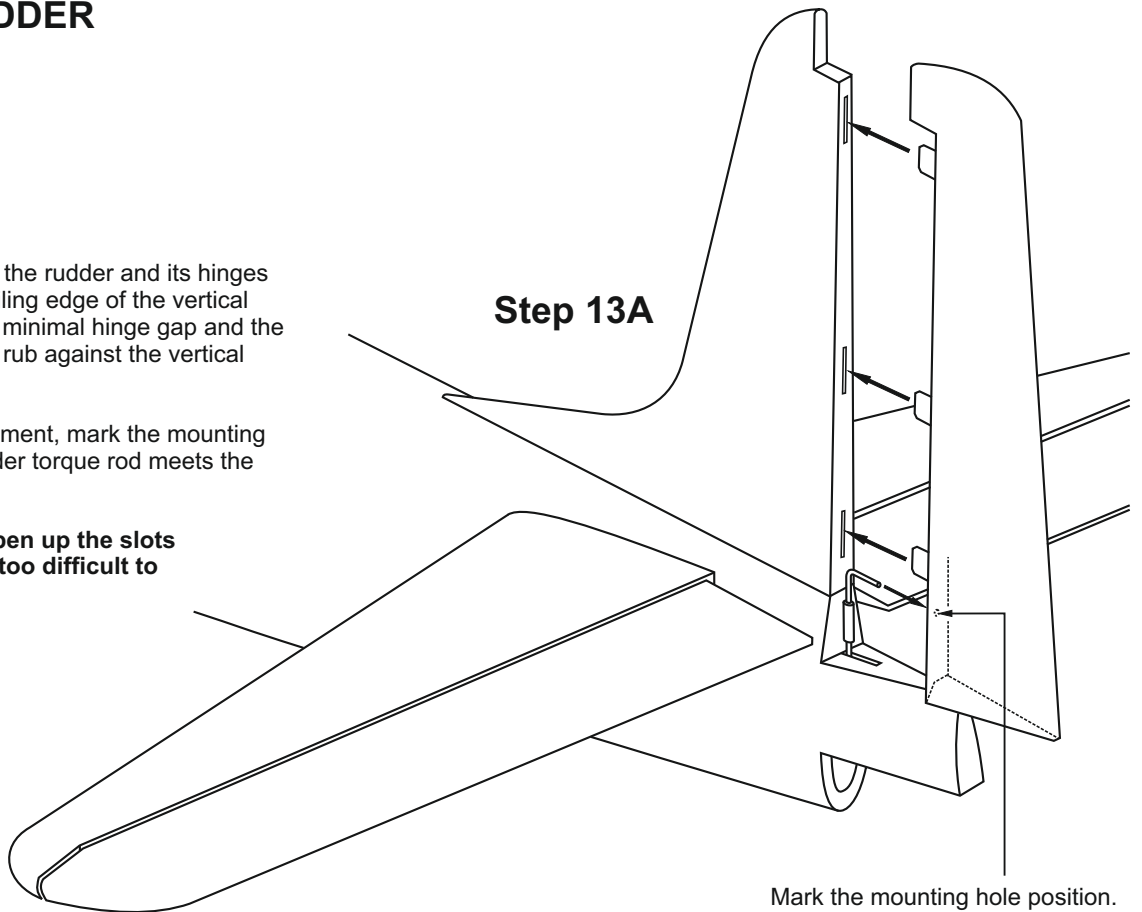

Mark the mounting hole position.

### Step 13B

Remove the rudder and drill 1/8" (3mm) diameter hole, making sure that you drill the hole perpendicular to the leading edge of the rudder.

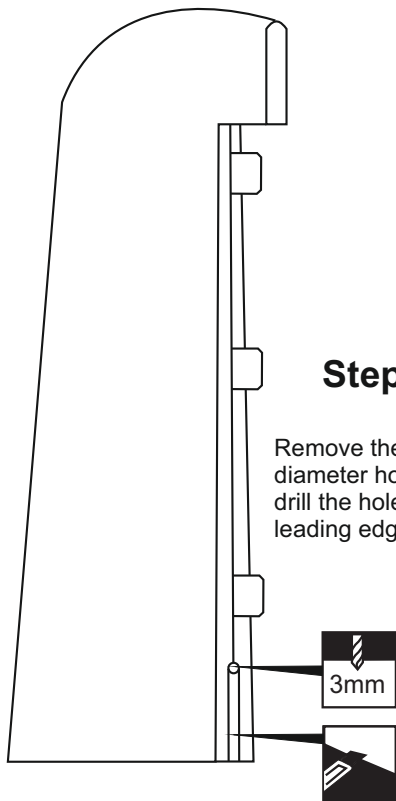

Cut the rudder torque rod mounting slot.

### Step 13C

Again, push the rudder and its hinges into the hinge slots, secure it place using 5 minutes Epoxy.

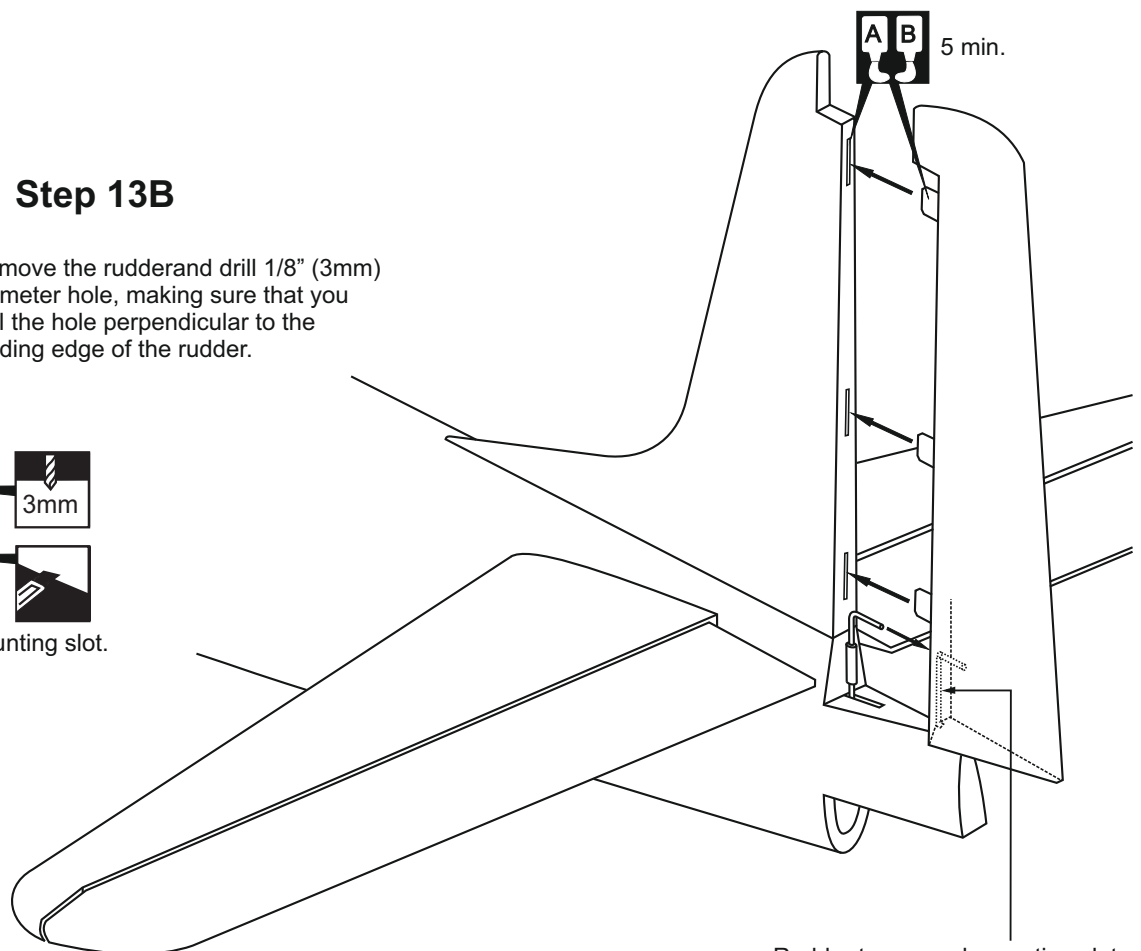

Rudder torque rod mounting slot



## SECTION 14 - ELEVATOR CONTROL HORN

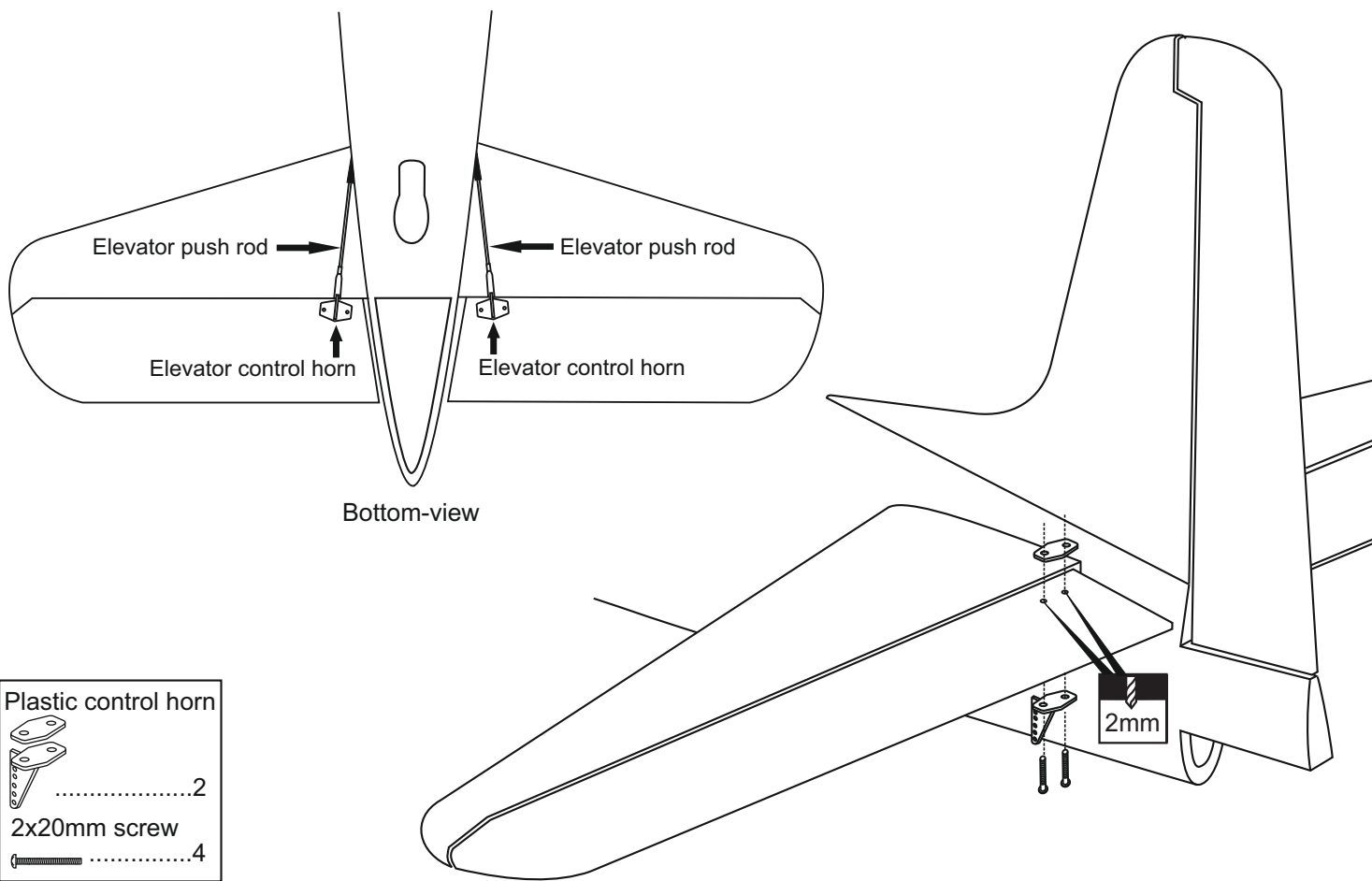

## SECTION 15 - TAIL WHEEL

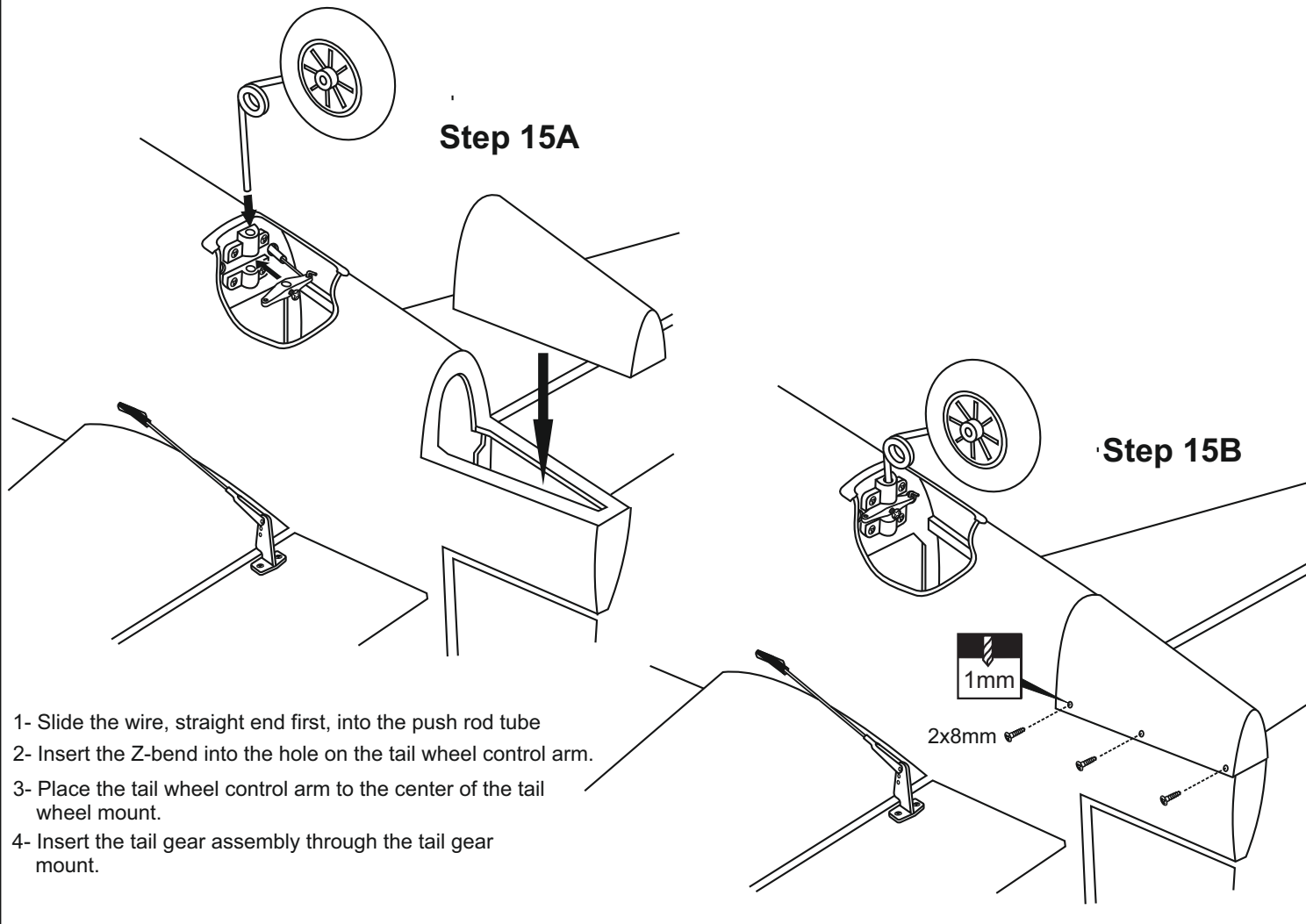

# SECTION 16 - SERVO

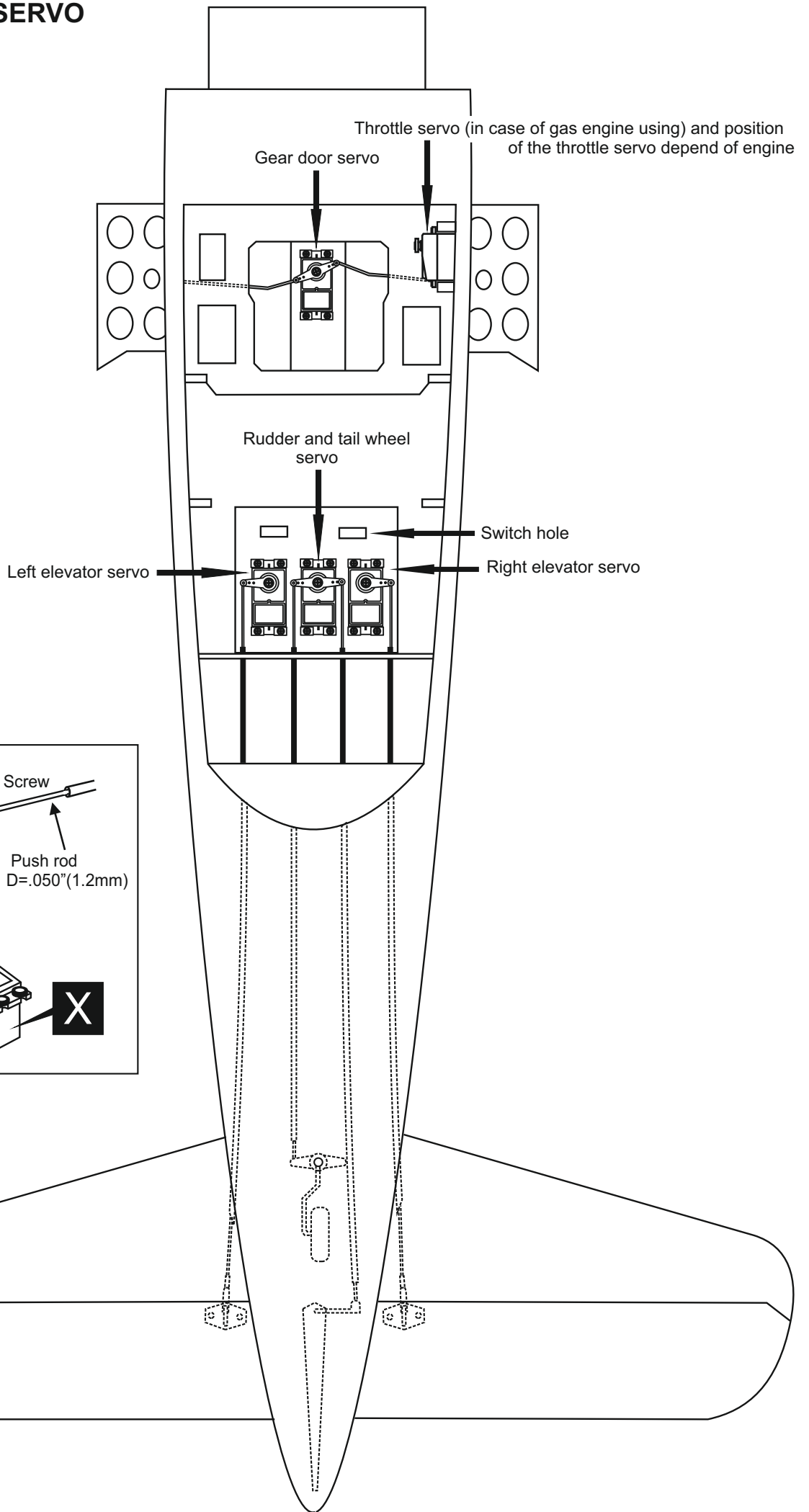

Connector

....7

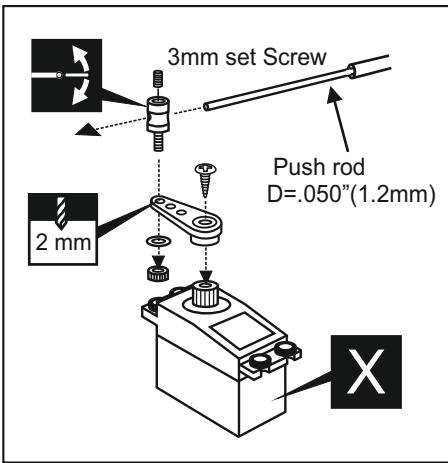

## SECTION 17 - GUNS

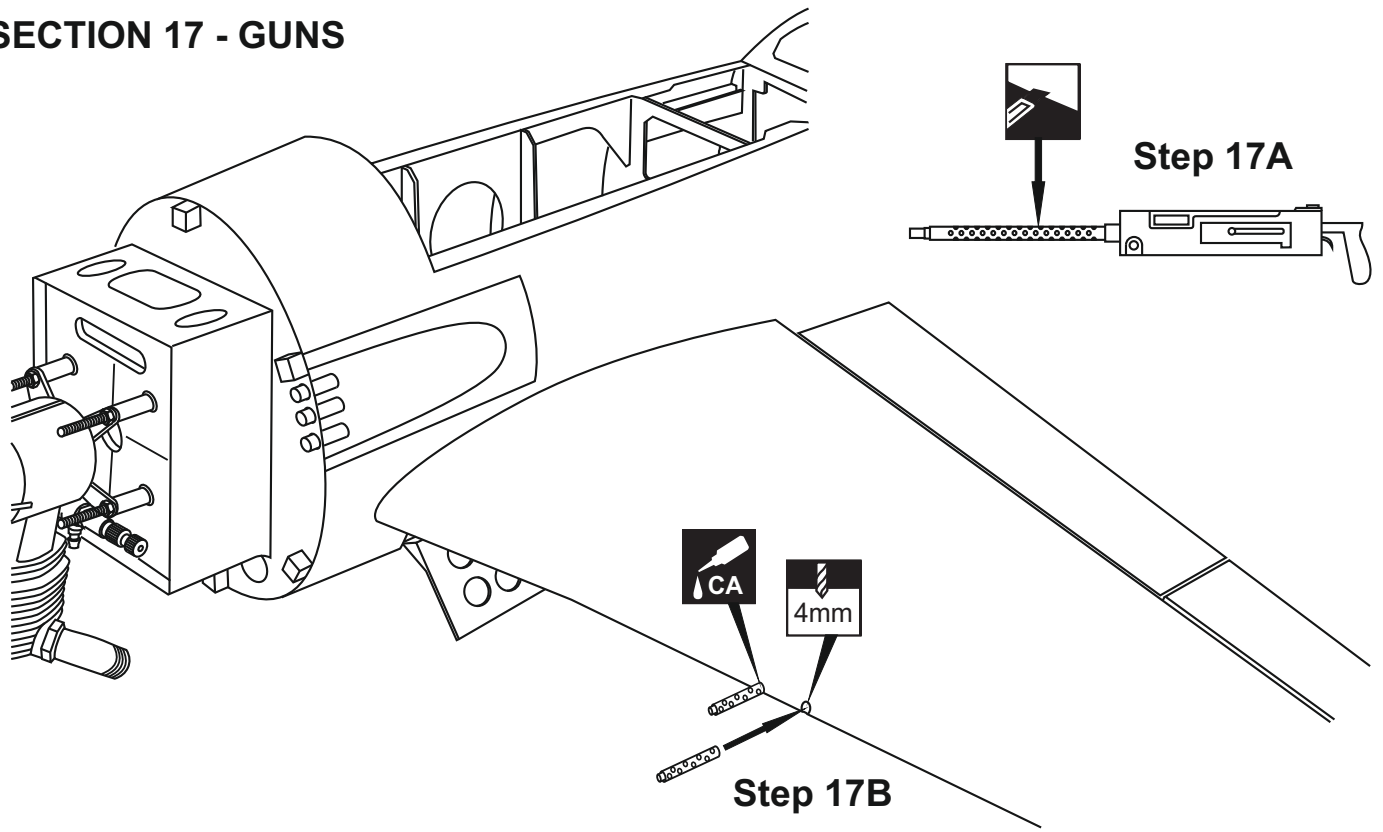

## SECTION 18 - COWLING

### Step 18A

### Step 18B

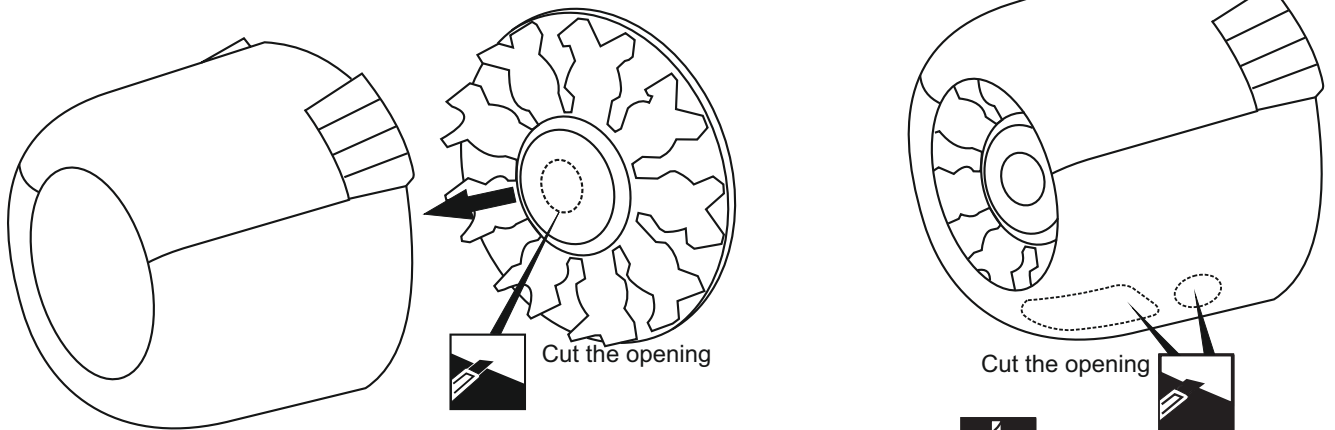

Secure the plastic dummy engine in place using 5 min. Epoxy

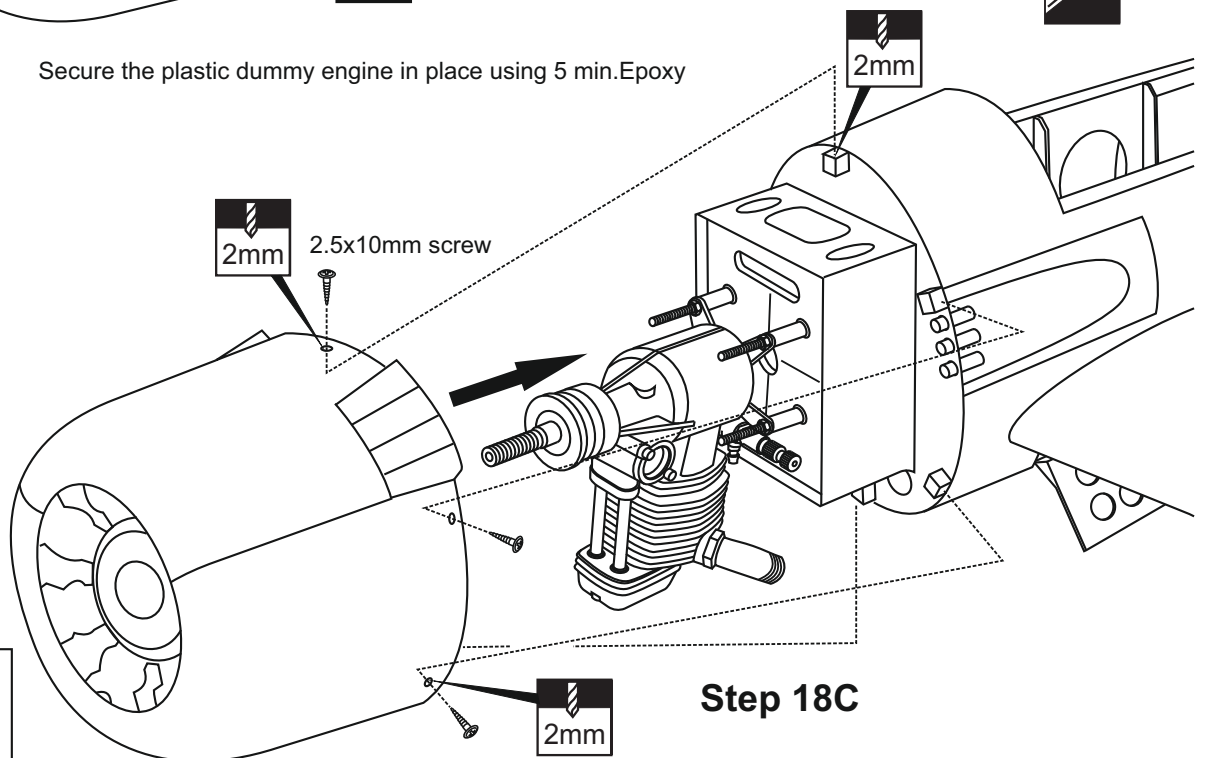

2.5x10mm screw

 .....6

## SECTION 19 - STRUTS

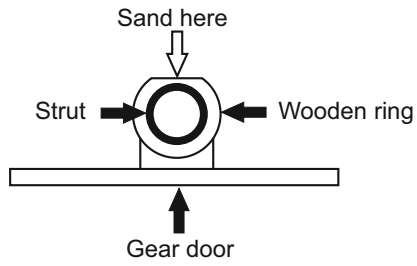
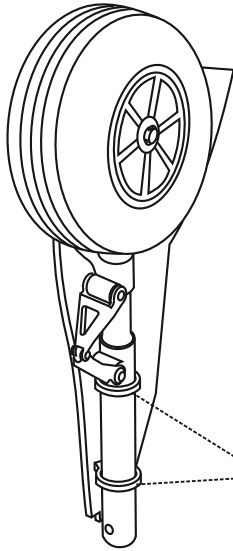

Lightly sand the wooden rings to be sure that the struts locks in down position.

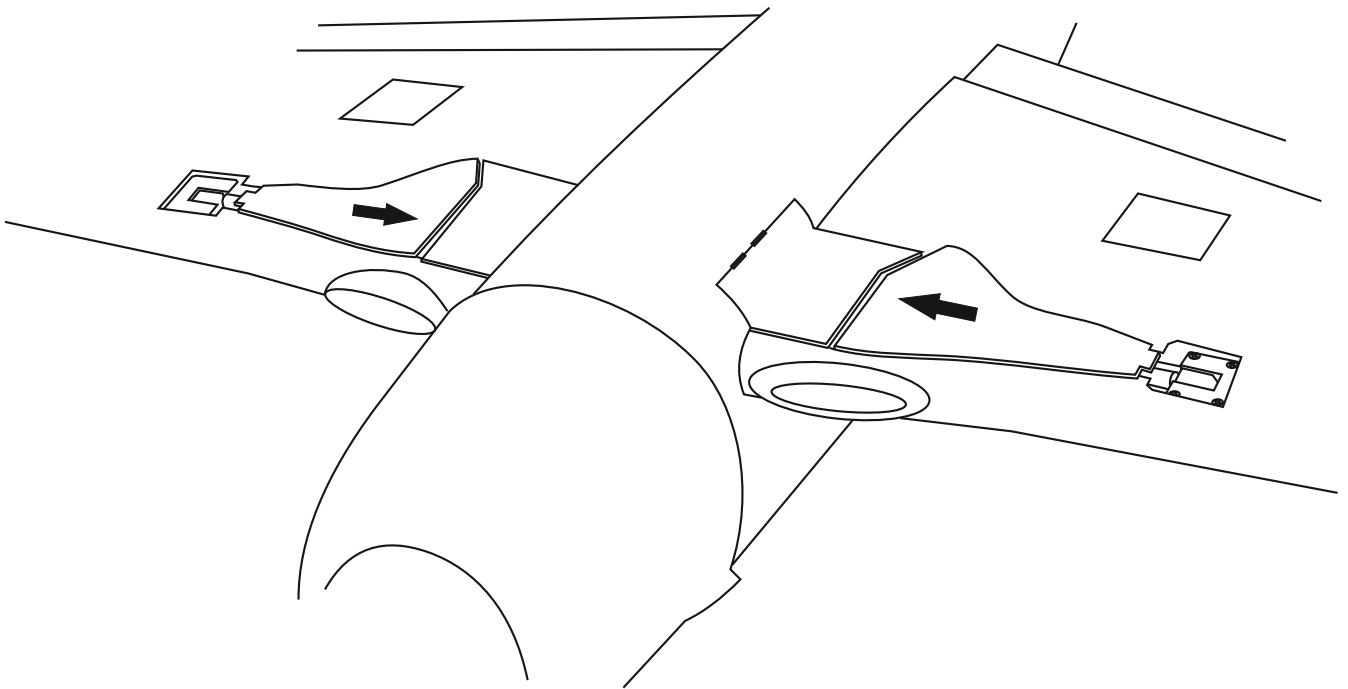

With the retract in the retracted position, carefully move the gear door on the strut until the gear door nearest with the gear door on the fuselage, mark on the struts.

With the retract in the extended position, Glue the rings of gear door to the struts with thin CA glue.

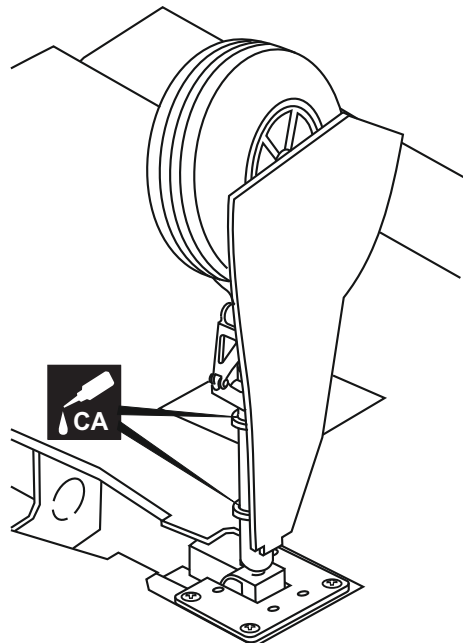

## SECTION 20 - BALANCE AND CONTROL SURFACE

Note: Adjust the location of the battery pack to achieve this C.G location.

DO NOT try to fly an out-of balance model!

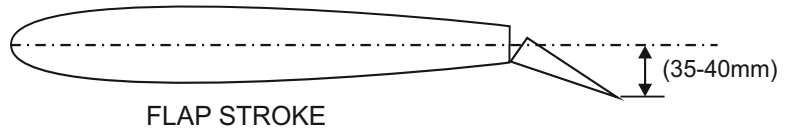
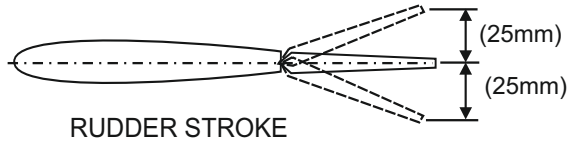
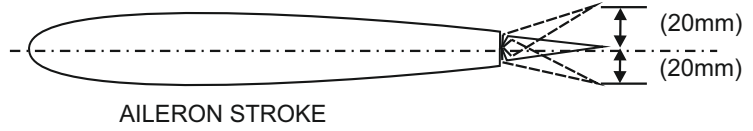
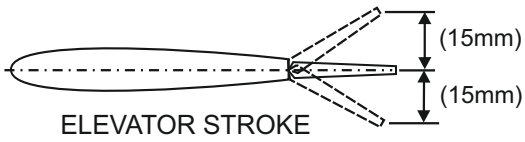
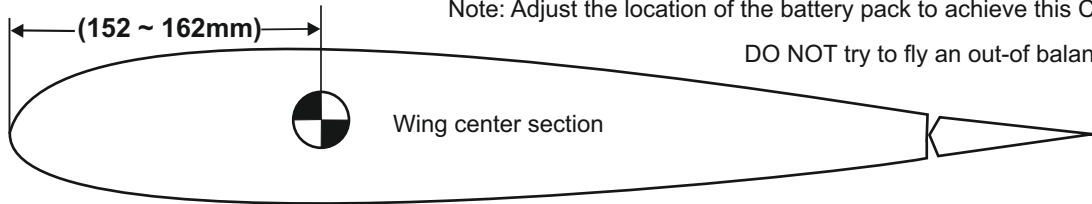

Adjust the travel of the control surfaces to achieve the values stated in the diagrams.

These values will be suitable for average flight requirements. Adjust the values to suit your particular needs.

## SECTION 22 - DECAL

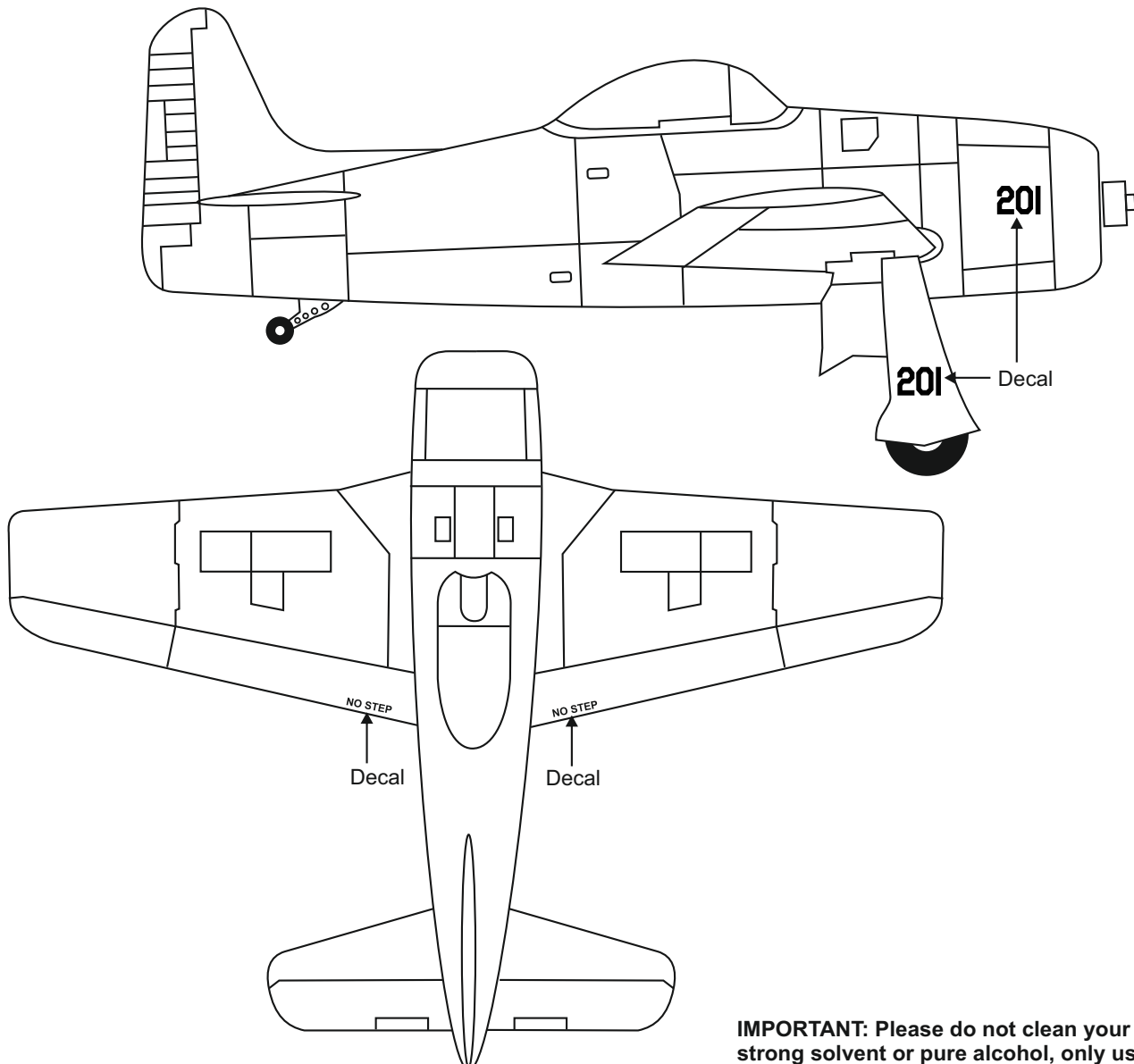

**IMPORTANT:** Please do not clean your model with strong solvent or pure alcohol, only use kerosene to keep the colour of your model not fade.