

# F-22 RAPTOR

## User Manual

70mm EDF JET

Wingspan:816mm

Length:1150mm

Empty Weight:1740G[w/o Battery]

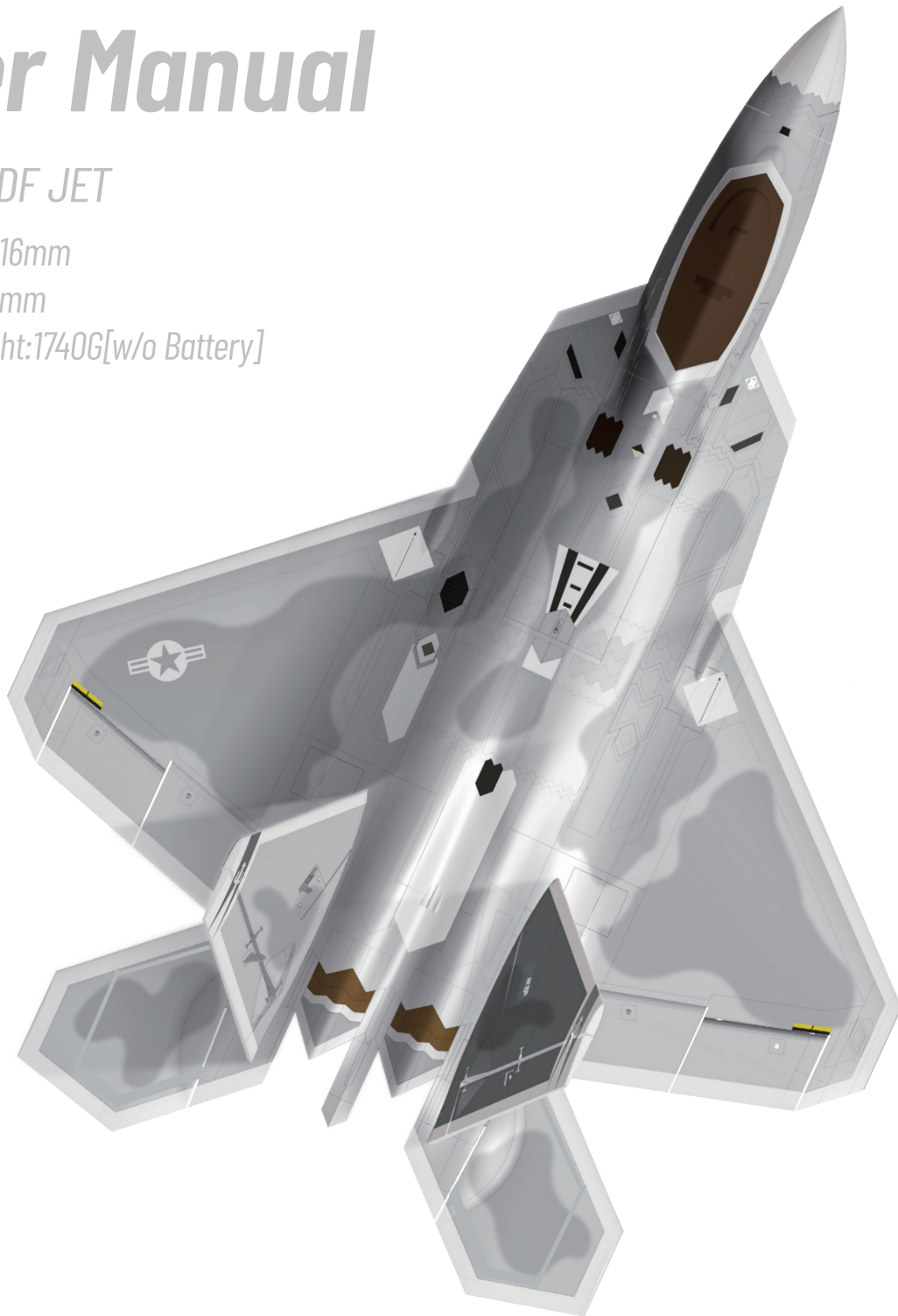

EN 1~10

中 11~20

1	Introduction
2	Product Basic Information
2	Package list
3	PNP Assembly Instructions
3	Install Horizontal Tail
3	Install Main Wing
5	Install Vertical Tail
5	Install Nose Cone
6	Battery Instructions
6	Pushrod Instructions
7	Center of gravity
8	Control Direction Test
9	Dual Rates
10	Servo Direction
10	Motor Specification

11	前言
12	产品规格参数
12	包装列表
13	PNP组装步骤介绍
13	平尾组装
13	主翼组装
15	垂尾组装
15	机头罩安装
16	电池介绍
16	舵面控制钢丝尺寸及安装孔位
17	重心示意图
18	模型舵面测试
19	舵量范围
20	舵机介绍
20	电机介绍

Thank you for purchasing our Freewing 70mm EDF super scale jet, F-22 Raptor. Before you assemble this F-22 model jet, please carefully read the instructions and follow the correct process for assembly and adjustment. If you encounter problems during assembly and debugging, please first resolve them by referring to the instructions. If the problem persists, please contact the distributor or directly contact us.

The F-22 Raptor is a single seat, twin engine, high stealth, supersonic fighter jet launched by Lockheed Martin in the United States. It is the world's first fifth generation fighter jet to enter service. This Freewing 1/16.5 scale F-22 Raptor 70mm EDF electric model jet uses EPO material, length is 1150mm, wing span is 817mm and uses the plastic structure and carbon tubes to strengthen. Standard grey camouflage color scheme used silver and grey color with a good metallic texture. The mold uses a concave convex pattern production process to make the surface of the aircraft appear more three-dimensional, presenting the concave convex details of the real fighter maintenance hatch. The vulnerable parts such as the fuselage and wings are protected with plastic covers to prevent damage. From a visual perspective, the edges appear sharper.

The PNP version can be assembled without glue. Among them, the main wing adopts the screw-less "QUICK" portable install structure. It makes the use and storage of the aircraft more convenient. The Freewing F-22 Raptor model jet uses electric retractable landing gear, while further improving the quality of the landing gear structure, with overall higher strength and smoother damping. In addition, it also includes front landing gear doors controlled by the servo, further reducing drag during flight. This model jet includes the rudder, aileron, flap and full elevator. When PNP at factory, it pre-installed with a 70mm 12 blade duct fan, a 2957-2210KV brushless in-runner motor, and an 80A ESC. Under this configuration, the maximum level flight speed reaches 170KM/H, and the powerful power brings a more enjoyable flying experience!

From the actual flying experience, the F-22 Raptor 70mm EDF model jet is very suitable as a beginner model jet. It has excellent flight stability, even in a low-speed cruising state at 30% throttle, still with excellent performance. Powerful power and fast power response make it very easy to complete various routine flight maneuvers. With the use of flaps, the aircraft can land at a slower speed and shorten the landing distance.

Thank you again. I hope this new F-22 Raptor model jet can bring you a better experience. I wish you a successful flight!

## Note:

- 1.This is not a toy! Operator should have a certain experience, beginners should operate under the guidance of professional players.
- 2.Before install, please read through the instructions carefully and operate strictly under instructions.
- 3.Cause of wrong operation,Freewing and its vendors will not be held responsible for any losses.
- 4.Model planes' players must be on the age of 14 years old.
- 5.This plane used the EPO material with surface spray paint, don't use chemical to clean, otherwise it will damage.
- 6.You should be careful to avoid flying in areas such as public places,high-voltage-intensive areas,near the highway, near the airport or any other place where laws and regulation clearly prohibit.
- 7.You cannot fly in bad weather conditions such as thunderstorms,snows....
- 8.Model plane's battery, don't allowed to put in everywhere. Storage must ensure that there is no inflammable and explosive materials in the round of 2M range.
- 9.Damaged or scrap battery should be properly recycled, it can't discard to avoid spontaneous combustion and fire.
- 10.In flying field, the waste after flying should be properly handled,it can't be abandoned or burned.
- 11.In any case, you must ensure that the throttle is in the low position and transmitter switch on, then it can connect the lipo-battery in aircraft.
- 12.Do not try to take planes by hand when flying or slow landing process. You must wait for landing stop, then carry it.

**⚠ NOTE:** This is not a toy. Not for children under 14 years. Young people under the age of 14 should only be permitted to operate this model under the instruction and supervision of an adult. Please keep these instructions for further reference after completing model assembly.

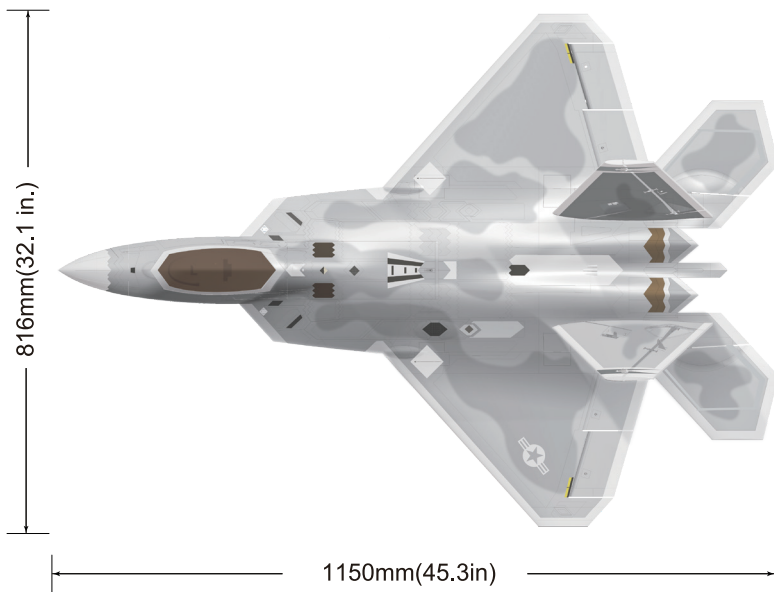

**Standard Version**

Wingload: 80g/dm<sup>2</sup>  
 Wing Area: 28.5dm<sup>2</sup>  
 Servo: 9gHybrid digital servo(9pcs)  
           9gDigital plastic servo(1pcs)  
 Motor: 2957-2210KV I/R Motor  
 Ducted fan: 70mm 12-blade fan  
 ESC: 80A Brushless(7A UBEC)  
 Weight: 1740g(w/o Battery)

**Other Notes**

Landing gear: Electric landing gear  
 Li-Po Battery: 6S 3500-5000mAh

**⚠ Note:** The parameters in here are derived from test result using our accessories.  
 If use other accessories, the test result will be different. Any problem since of using other accessories, we are not able to provide technical support.

**Package List**

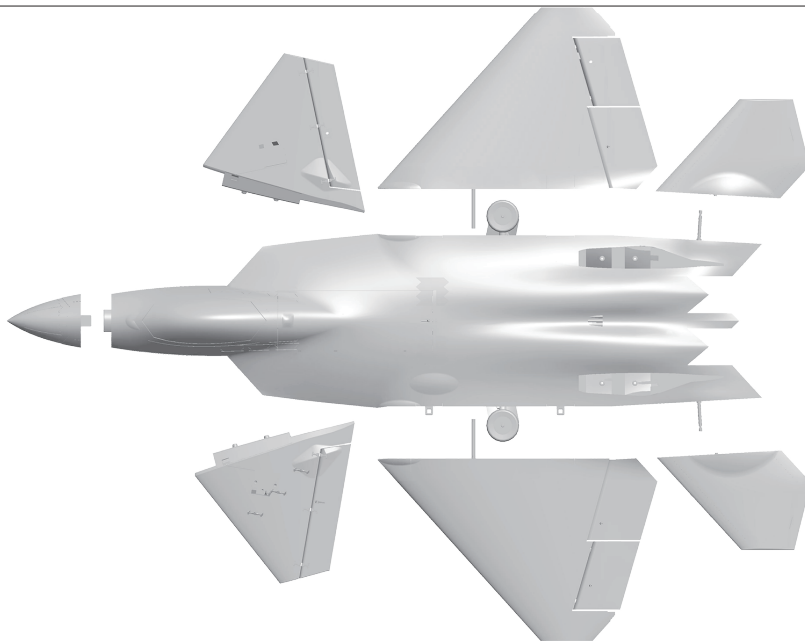

Different equipment include different spareparts. Please refer to the following contents to check your sparepart list.

No.	Name	PNP	ARF Plus
1	Fuselage	Pre-installed all electronic parts	Pre-installed servo
2	Main wing	Pre-installed all electronic parts	Pre-installed servo
3	Horizontal tail	Pre-installed all electronic parts	Pre-installed servo
4	Vertical tail	Pre-installed all electronic parts	Pre-installed servo
5	Nose cone	✓	✓

No.	Name	PNP	ARF Plus
6	Cockpit	✓	✓
7	Landing gear	✓	✓
8	Annex bag	✓	✓
9	Manual	✓	✓

## Install Horizontal Tail

As the photo show:

1. Place the horizontal tail on the rotating shaft at the rear fuselage and push it to the fuselage.

Then fix with screws to prevent its fall off.  
(Repeat this step for the other Horizontal tail)

Attention: When the screw is tightened all the way down, please stop immediately when the resistance suddenly increases; Then twist the screw in the opposite direction by half a turn, leaving a certain gap between the screw and the groove of the rotating shaft. At this point, rotating the horizontal tail can move normally, and pulling the horizontal tail outward, it will not fall off, indicating that the installation meets the requirements.

Screw (KM 3\*6mm 2PCS)

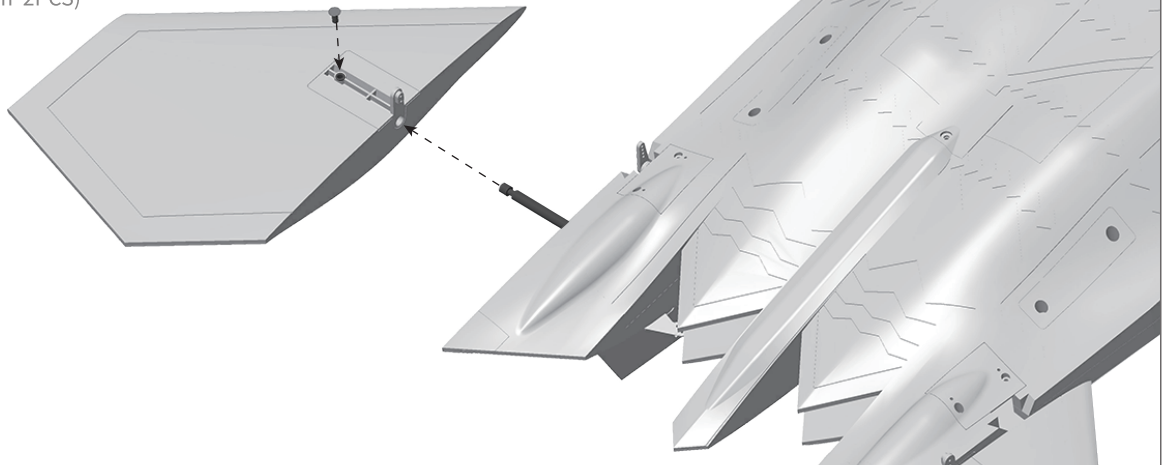

## Install Main Wing

As the photo show:

1. Press the main wing screw-less quick install switch to unlock it ①,

① Two different status diagrams of the main wing screw-less quick install switch: (The working mode is to press the button to the bottom and release it. The button pops up to the highest position, which is the unlocked status. Once the button is pressed to the bottom again and released, but the button does not pop up, which is the locked status)

### Unlock status

As shown in the following photo:

Press the main wing screw-less quick install switch to the bottom and release it. The button pops up to the highest position, indicating that the main wing has been unlocked and can be easily removed and installed.

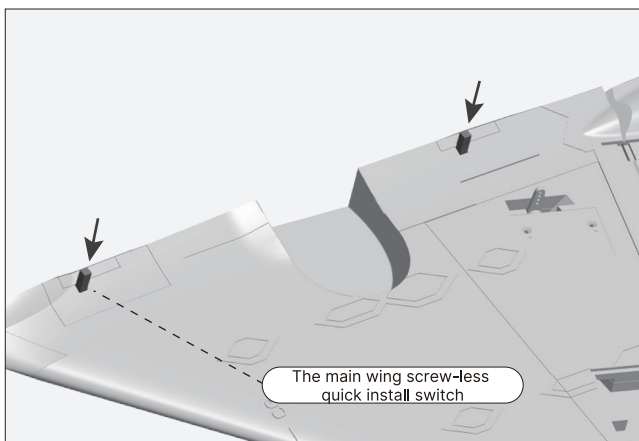

### Lock status

As shown in the following photo:

After installed the main wing, press again the main wing screw-less quick install switch to the bottom and release it. If the button does not pop up, it is the locked status. At this point, pull the main wing outward and can not remove it.

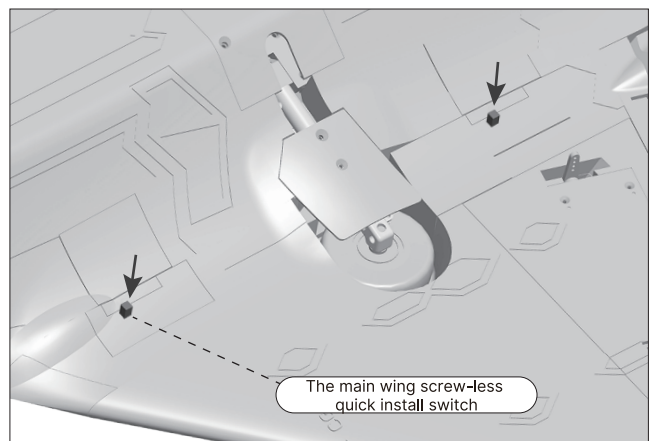

**Install Main Wing**

2. Align the main wing carbon tube with the fuselage, remove the ribbon cable from one end of the fuselage, connect it to the main wing slot, and push the main wing into the installation position of the fuselage;  
(Repeat this step for the other main wing)

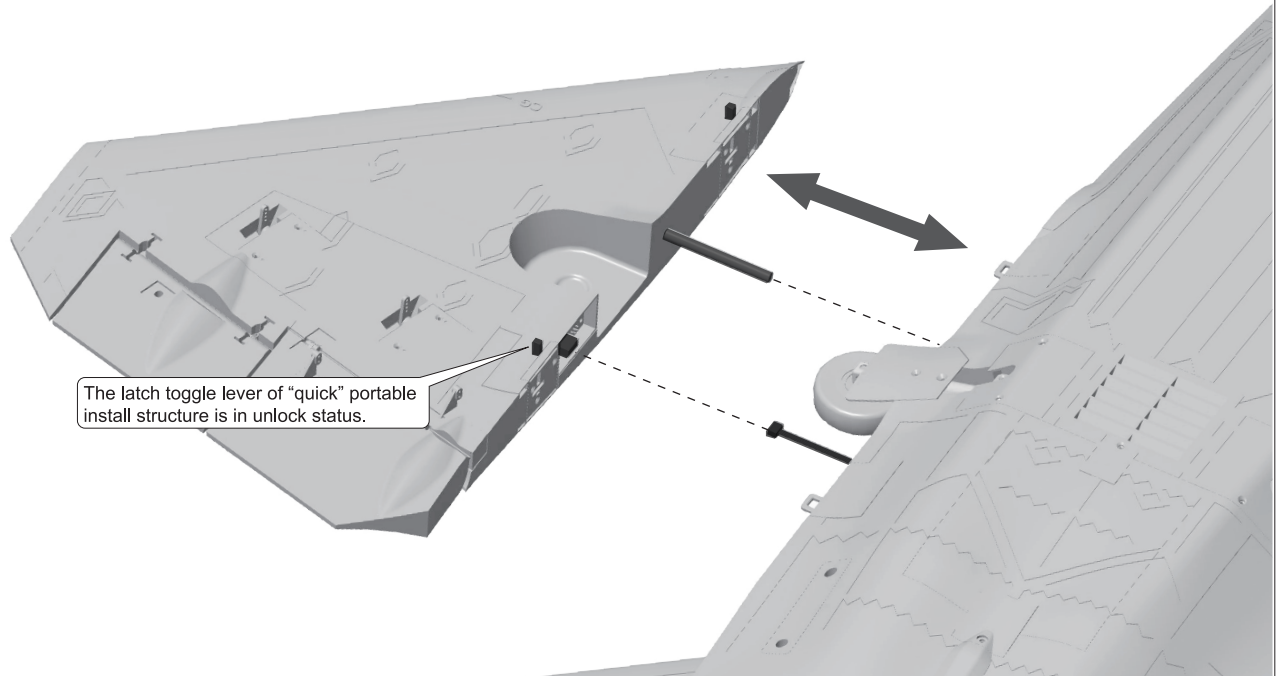
**Install Main Wing**

3. Press 4pcs main wing screw-less quick install switch, put it in the locked status.

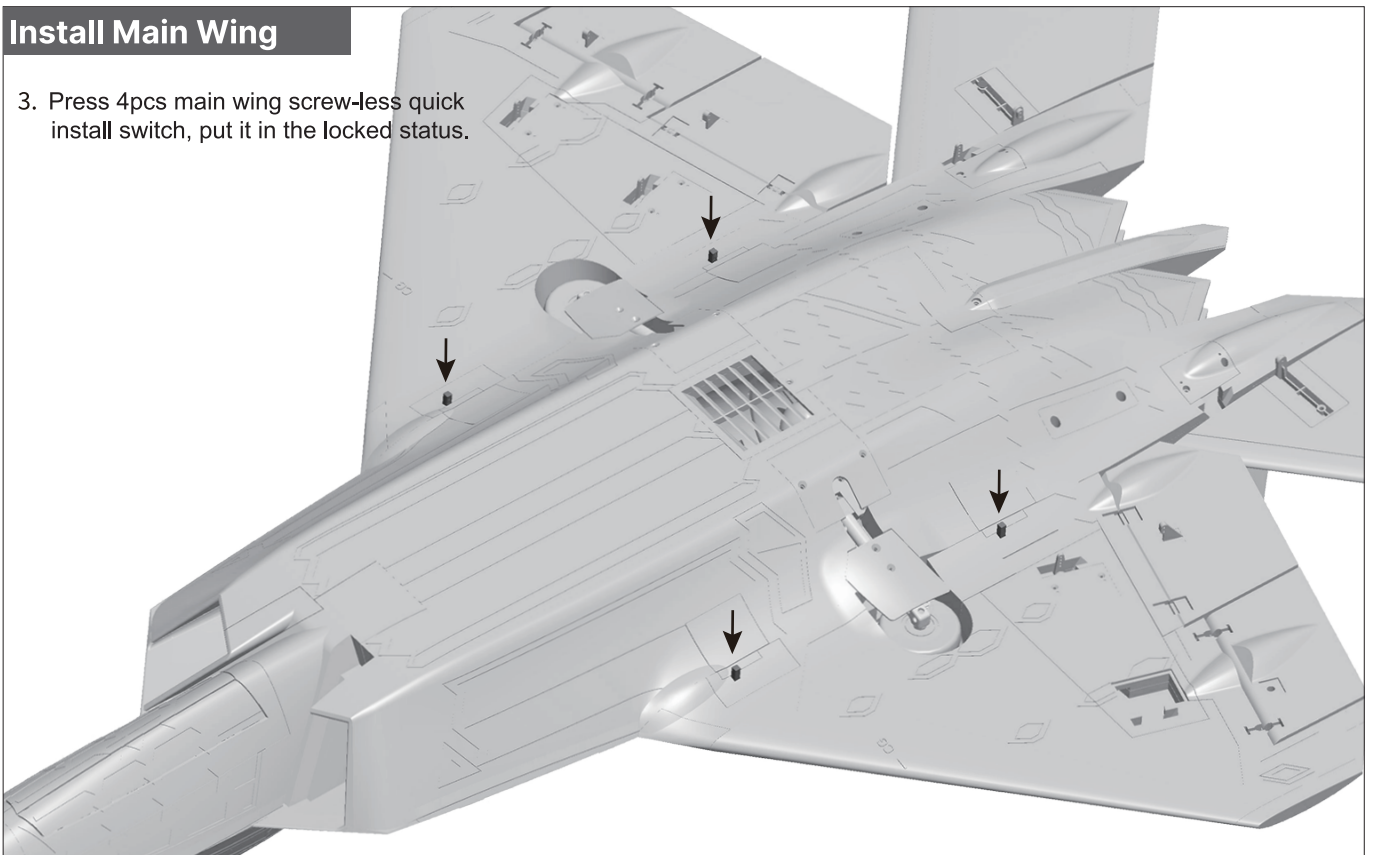

## Install Vertical Tail

As the photo show:

1. Connect the vertical tail servo cable to the servo extension cable, ensuring that the extension cable clamp is fully hooked onto the servo cable plug;
2. Insert the vertical tail into the fuselage, turn over the fuselage, and then tighten it with screws.  
(Repeat this step for the other vertical tail)

Screw (KM3\*6mm 4PCS)

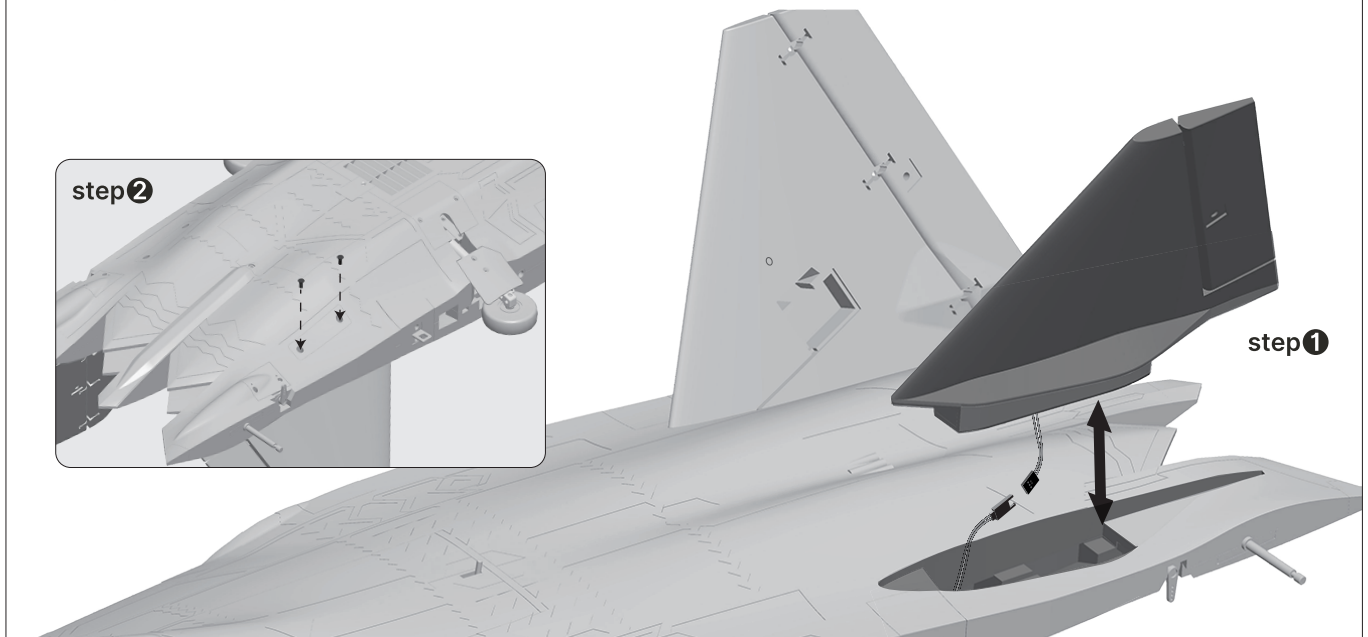

## Install Nose Cone

As the photo show:

1. Install the nose cone onto the fuselage

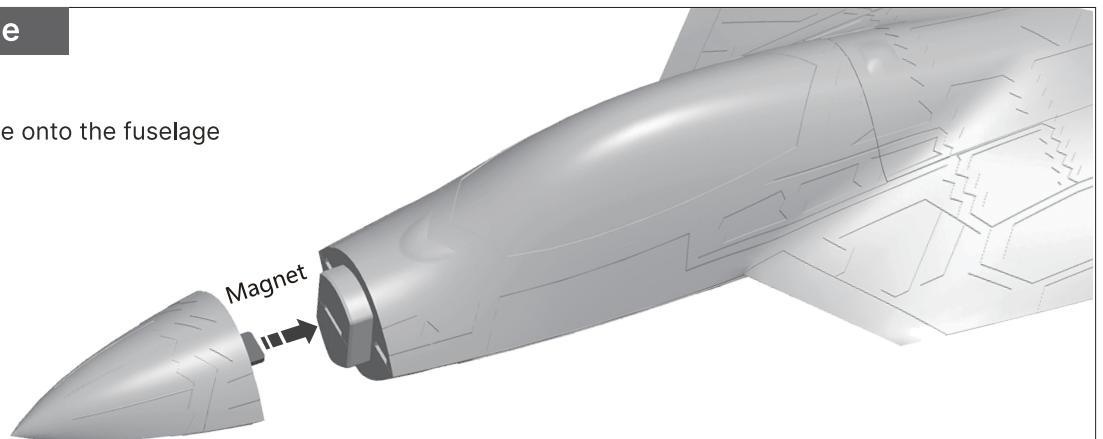

## Install Battery

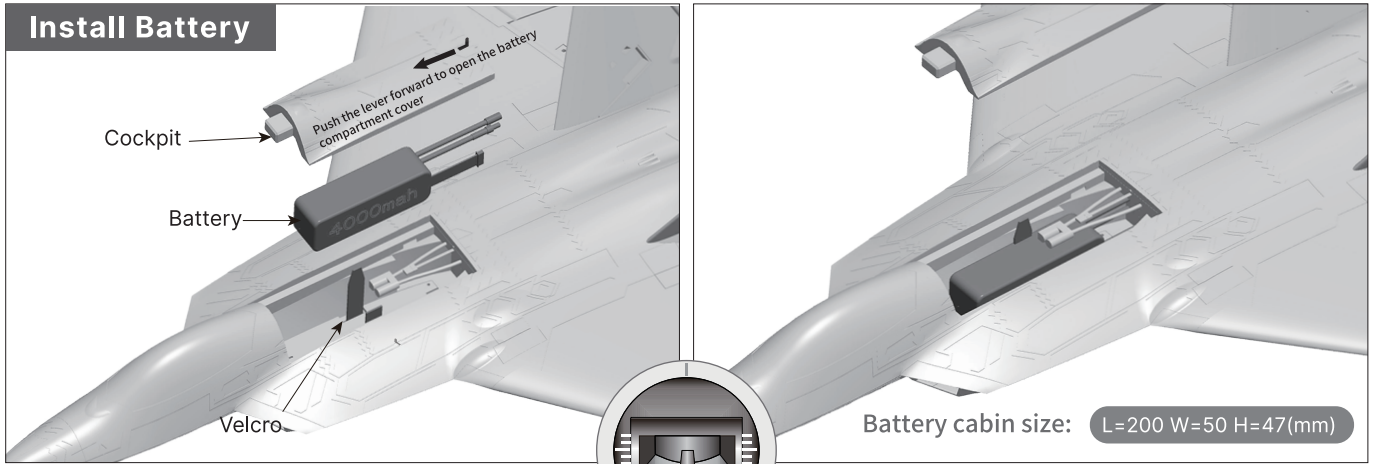

Before connecting the battery and receiver, please switch on the transmitter power and make sure the throttle stick is in the lowest position. Bind your receiver to your transmitter according to your transmitter's instruction manual.

We recommend the following LiPo battery:  
**6S 22.2V 3500mAh~6S 22.2V 5000mAh (1pcs)**  
 Discharge rate of C ≥35C

## Pushrod Instructions

### Aileron pushrod length

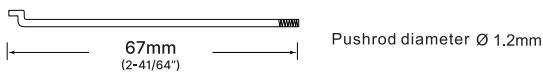

### Aileron pushrod mounting hole



### Rudder pushrod length

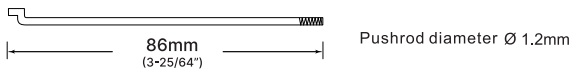

### Rudder pushrod mounting hole

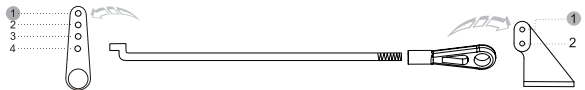

### Flap pushrod length

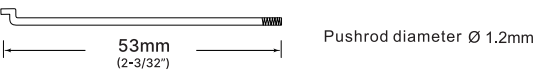

### Flap pushrod mounting hole(Inside)



### Elevator pushrod length

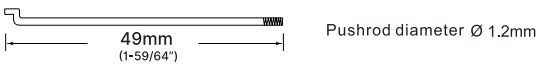

### Elevator pushrod mounting hole

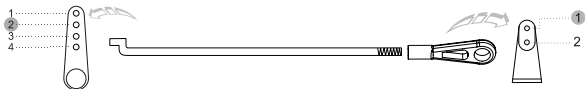

### Nose gear steering pushrod length

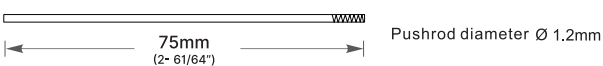

### Nose gear steering pushrod mounting hole

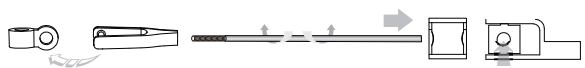

### Nose Cabin door pushrod length



### Nose cabin door pushrod mounting hole

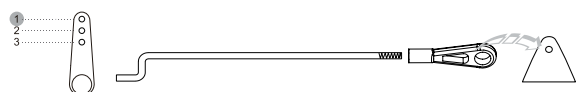



## Important additional notes

The Y-type clevis used in this product is equipped with a transparent silicone ring for secondary reinforcement, which can effectively prevent the clevis from accidentally loosening.

As shown in the following figure, when you buckle the clevis into the control surface horn, use the silicone ring to cover the clevis.

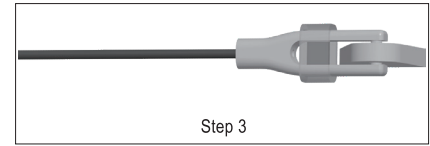
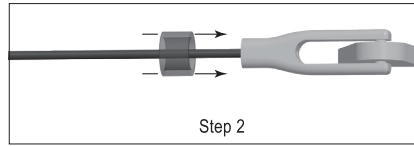
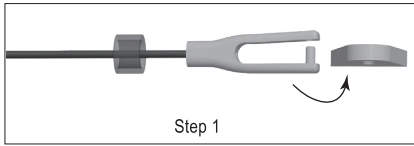

## Center of Gravity

Correct Center of Gravity ("CG") is critical for enabling safe aircraft stability and responsive control. Please refer to the following CG diagram to adjust your aircraft's Center of Gravity.

- Depending on the capacity and weight of your chosen flight batteries, move the battery forward or backward to adjust the Center of Gravity.
- If you cannot obtain the recommended CG by moving the battery to a suitable location, you can also install a counterweight to achieve correct CG. However, with the recommended battery size, a counterweight is not required. We recommend flying without unnecessary counterweight.

As the photo show, We marked the center of gravity on the bottom of the Main wing. Please confirm the CG based on this marked position.

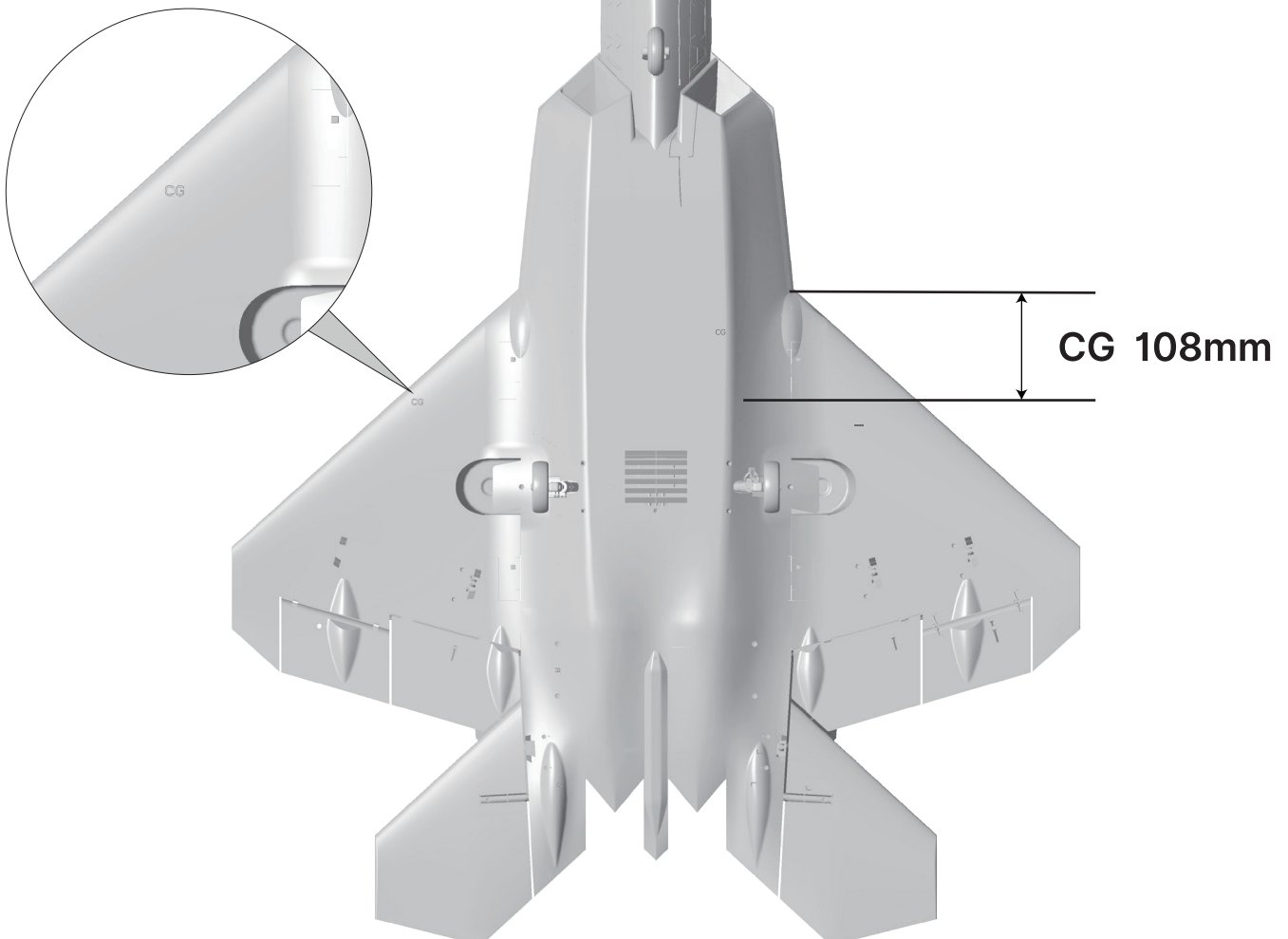

After installed this F22 model plane, please connect to the receiver and power on, then adjust it.

1. When all channels of radio are fine tuned to zero and the control stick is centered: check whether each control surface on the aircraft is in the center position. If it is found that the control surface is not in the center position, please adjust the control rod to center it;

2. Please refer to the diagram below and use the radio to test each control surface to ensure that its movement direction matches the diagram. If the opposite movement occurs, first check whether the relevant channel in the radio has enabled the reverse function; If the problem persists, please contact us for assistance in resolving it.

## Aileron

Stick Left



Stick Right

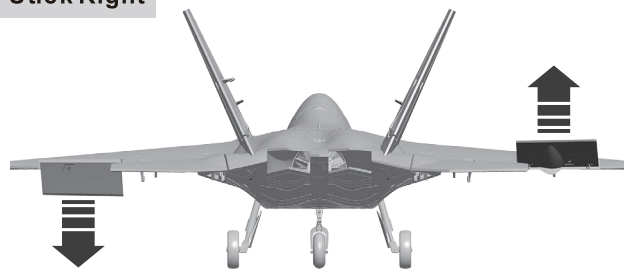

## Rudder

Stick Left

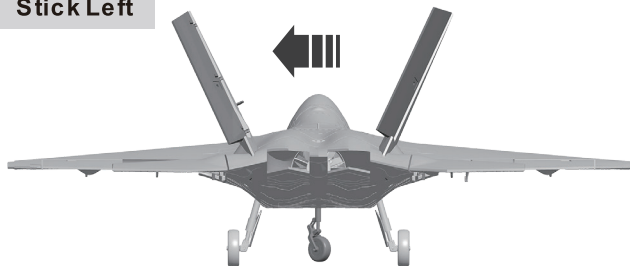

Stick Right



## Elevator

Stick down



Stick up

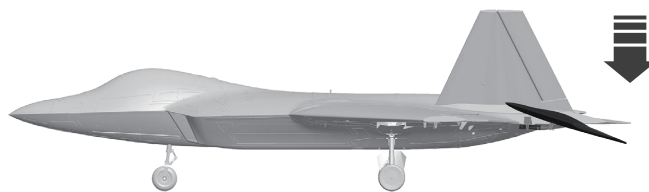

## Flaps

Flaps down

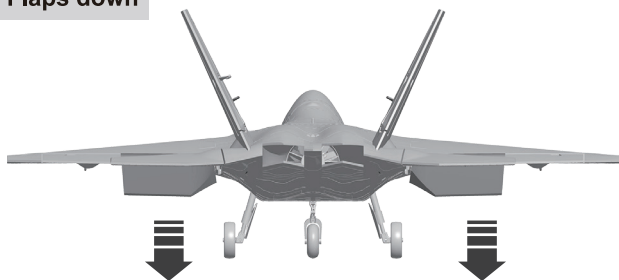

**Dual Rates**

According to our testing experience, use the following parameters to set Aileron/Elevator Rate. Program your preferred Exponential % in your radio transmitter. We recommend using High Rate for the first flight, and switching to Low Rate if you desire a lower sensitivity. On successive flights, adjust the Rates and Expo to suit your preference.

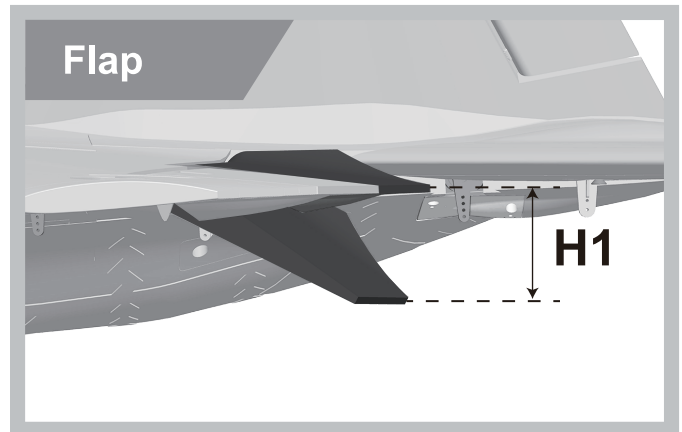
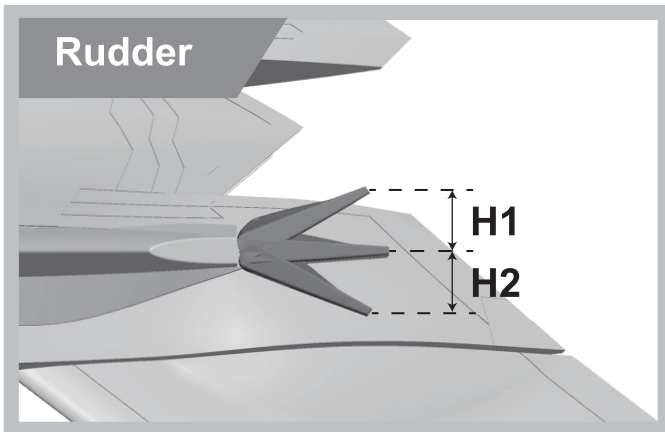
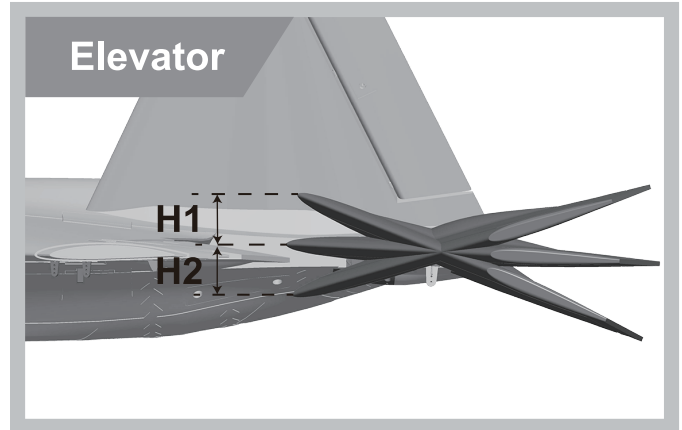
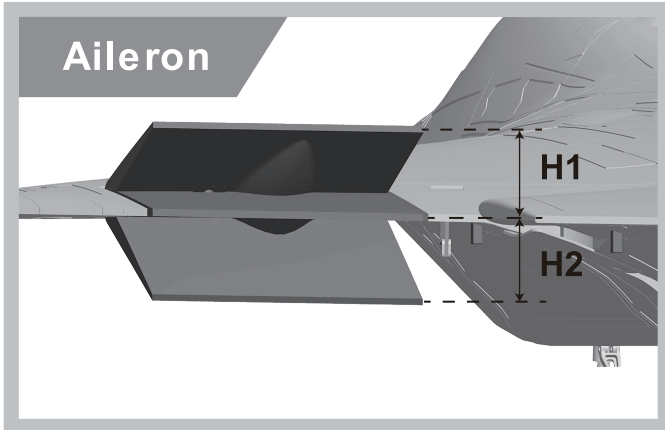

	<b>Aileron</b> (Measured closest to the fuselage)	<b>Elevator</b> (Measured closest to the fuselage)	<b>Rudder</b> (Measured from the bottom)	<b>Flaps</b>
<b>Low Rate</b>	H1/H2 25mm/25mm D/R Rate: 80%	H1/H2 23mm/23mm D/R Rate: 60%	H1/H2 16mm/16mm D/R Rate: 80%	H1 24mm
<b>High Rate</b>	H1/H2 30mm/30mm D/R Rate: 100%	H1/H2 29mm/29mm D/R Rate: 80%	H1/H2 23mm/23mm D/R Rate: 100%	H1 33mm

**Remote Control EXP Setting Suggestion**

1. Aileron EXP curve is shown as below :

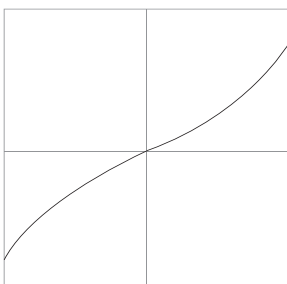

Futaba brand Remote Control : EXP A -30  
EXP B -30

Spektrum brand Remote Control : EXPO 30% 30%

2. Elevator EXP curve is shown as below :

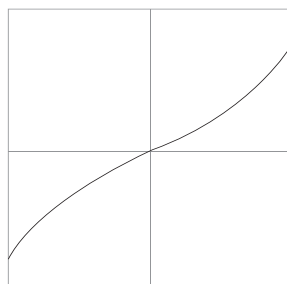

Futaba brand Remote Control : EXP A -30  
EXP B -30

Spektrum brand Remote Control : EXPO 30% 30%

3. Rudder EXP curve is shown as below :

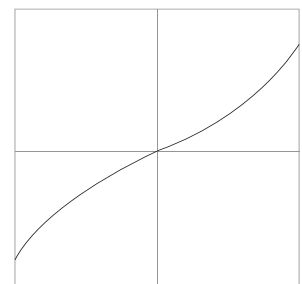

Futaba brand Remote Control : EXP A -30  
EXP B -30

Spektrum brand Remote Control : EXPO 30% 30%

## horizontal tail center position

1. Please refer to the image on the right and adjust the horizontal tail to the correct center position.

Distance from the leading edge of the horizontal tail wing root (at the forefront position) to the upper surface of the fuselage: 8mm

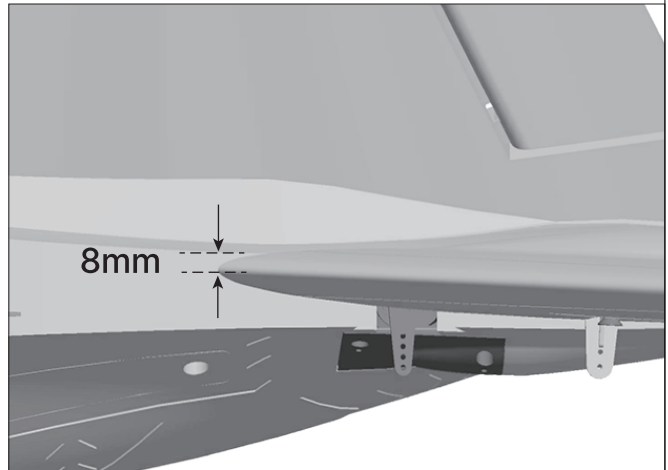

## Servo Direction

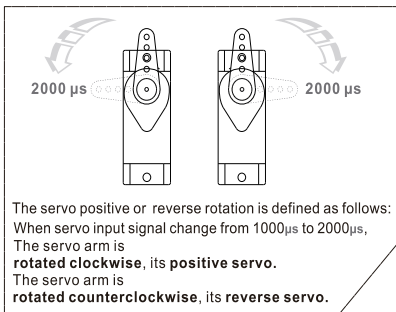

If you need to purchase another brand's servo, please refer to the following list to choose a suitable servo.

Position	Servo regulation	No.	Pos. / Rev.	Cable length
Nose gear steering servo	9g Digital-Hybrid	1	Positive	200mm
Nose cabin door	9g plastic servo	2	Positive	300mm
Aileron(L)	9g Digital-Hybrid	3	Positive	200mm
Aileron(R)	9g Digital-Hybrid	4	Positive	200mm
Flap(L)	9g Digital-Hybrid	5	Positive	100mm
Flap(R)	9g Digital-Hybrid	6	Positive	100mm
Elevator(L)	9g Digital-Hybrid	7	Positive	100mm
Elevator(R)	9g Digital-Hybrid	8	Reverse	100mm
Rudder(L)	9g Digital-Hybrid	9	Positive	100mm
Rudder(R)	9g Digital-Hybrid	10	Positive	100mm

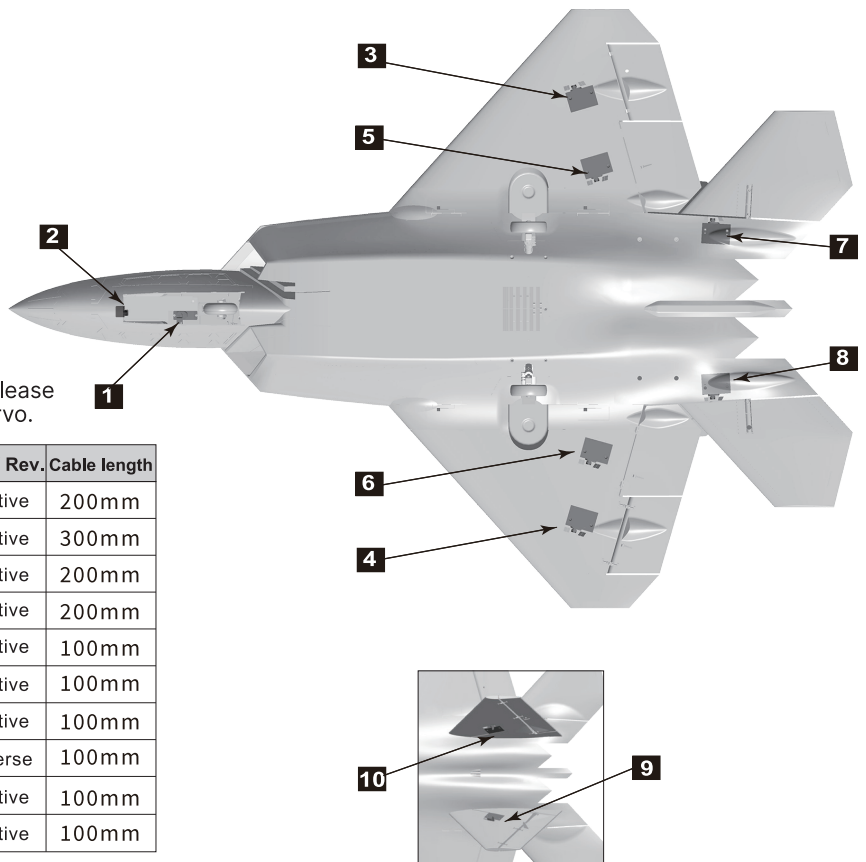

## Motor Specification

Item No. MI029571  
2957-2210KV

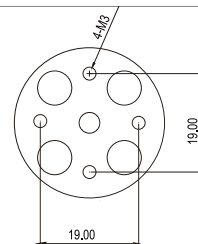
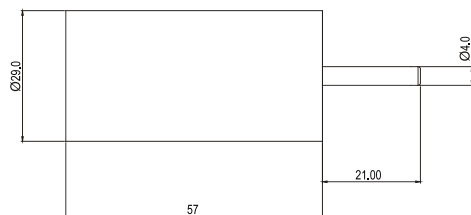

2957-2210KV

Item No.	Motor size	Motor(KV)	Thrust(g)	Current(A)	Use Voltage (V)	Use ESC (A)	EDF Weight (g)	Max power (W)	Efficiency (g/w)
E7218	2957-2210KV	2210KV	2600	70	22 2 (6S)	80	240	1550	1 68



**Dongguan Freewing Electronic Technology Ltd**  
**HK Freewing Model International Limited**

Add.: FeiYi Building, 402-408#, Fumin Middle Road, Dalang Town,  
Dongguan City, Guangdong Province, China

Web: <http://www.sz-freewing.com> [www.freewingmodel.com](http://www.freewingmodel.com)

Email: [freewing@sz-freewing.com](mailto:freewing@sz-freewing.com)

Tel: 86-769-82669669 Fax: 86-769-82033233

东莞市飞翼电子科技有限公司  
香港飞翼模型国际有限公司

地址: 广东省东莞市大朗镇富民中路402-408号飞翼楼四楼

Web: <http://www.sz-freewing.com> [www.freewingmodel.com](http://www.freewingmodel.com)

Email: [freewing@sz-freewing.com](mailto:freewing@sz-freewing.com)

Tel: 86-769-82669669 Fax: 86-769-82033233

