

**M<sup>odel</sup> Freewing**

# F-4 PHANTOM II

**Freewing 1/11 Scale EDF Jet**

**Wingspan:1030mm**

**Length:1550mm**

**Empty Weight:2850G (w/o Battery)**



EN

1~10

中

11~20



[www.sz-freewing.com](http://www.sz-freewing.com)

MADE IN CHINA

Introduction.....	1
Basic Product Information.....	2
Package List.....	2
<b>PNP Assembly Instructions</b>	
Traction steel wire use instruction .....	3
Install Fuselage.....	3
Install Horizontal Stabilizer .....	3
Install Vertical Stabilizer.....	4
Install Main wing.....	4
Install Scale Accessories.....	5
Pushrod instructions.....	5
Control board connection diagram.....	6
Battery Size.....	7
Center of Gravity.....	7
Servo Direction .....	8
Motor Specification.....	8
Control Direction Test.....	9
Dual Rates and Flight Attention.....	10
前言.....	11
产品基本参数.....	12
产品包装清单.....	12
<b>PNP组装说明</b>	
牵引钢丝使用说明.....	13
机身组装.....	13
平尾组装.....	13
垂尾组装.....	14
主翼组装.....	14
仿真小配件 .....	15
舵面控制钢丝尺寸.....	15
集线板连接示意图.....	16
电池安装说明.....	17
重心示意图 .....	17
舵机使用说明.....	18
电机参数 .....	18
舵面测试.....	19
大、小舵参数及飞行注意事项.....	20

Freewing are proud to introduce our 90mm Super Scale F-4 Phantom III! For more than 50 years, the F-4 Phantom delivered the versatile capabilities required of a superior weapons platform.

We developed this F-4 to deliver reliability, durability, and performance from your very first flight. Grass operation is a hallmark of the Freewing 90mm F-4. With its wide stance, tall main tires, and suspension landing struts, this aircraft performs well on rougher grass runways.

Super scale details include accurate landing lights, nose wheel doors, DayBright position lights, rivet detail, arrestor hook, and ordnance. Representing the famed aircraft BuNos 67-463 operated by pilot Richard "Steve" Ritchie and weapons systems officer Charles "Chuck" DeBellevue when they scored their fifth kill together on May 10, 1972 over Vietnam, the Freewing 90mm F-4 arrives pre-painted in classic SEA (South East Asia) Camo and proudly wears the markings of the 555th TFS. BuNos 67-463 became a bona fide "MiG Killer", being credited for six aerial kills with five different flight crews.

Such a large RC model aircraft remains easy to transport with magnetic removable fiberglass nose cone and removable wings with a convenient flexible wire harness that attaches at each wing root. A specially designed elevator mechanism incorporates bearings for smooth rotation at all times.

The Freewing 90mm F-4 Phantom II is available in two power system versions. The Standard version requires a 6s 5000-6000mAh battery, and is our top recommendation to pilots seeking the best balance between speed, thrust, and cost. The High Performance version requires an 8s 4000-5000mAh battery, and delivers increased vertical climbing performance and acceleration.

**⚠ NOTE:** This is not a toy. Not for children under 14 years. Young people under the age of 14 should only be permitted to operate this model under the instruction and supervision of an adult. Please keep these instructions for further reference after completing model assembly.

## Note:

1. This is not a toy! Operator should have a certain experience, beginners should operate under the guidance of professional players.
2. Before install, please read through the instructions carefully and operate strictly under instructions.
3. Cause of wrong operation, Freewing and its vendors will not be held responsible for any losses.
4. Model planes' players must be on the age of 14 years old.
5. This plane used the EPO material with surface spray paint, don't use chemical to clean, otherwise it will damage.
6. You should be careful to avoid flying in areas such as public places, high-voltage-intensive areas, near the highway, near the airport or any other place where laws and regulation clearly prohibit.
7. You cannot fly in bad weather conditions such as thunderstorms, snows....
8. Model plane's battery, don't allowed to put in everywhere. Storage must ensure that there is no inflammable and explosive materials in the round of 2M range.
9. Damaged or scrap battery should be properly recycled, it can't discard to avoid spontaneous combustion and fire.
10. In flying field, the waste after flying should be properly handled, it can't be abandoned or burned.
11. In any case, you must ensure that the throttle is in the low position and transmitter switch on, then it can connect the lipo-battery in aircraft.
12. Do not try to take planes by hand when flying or slow landing process. You must wait for landing stop, then carry it.

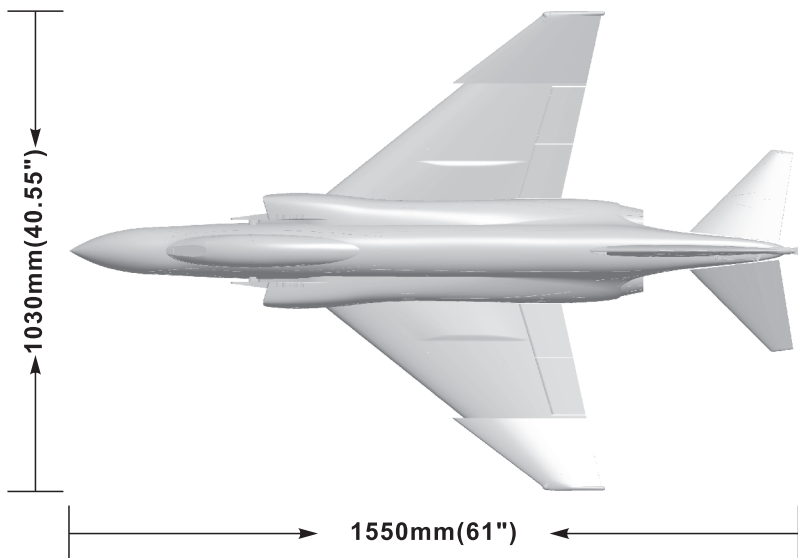

**Note:** The parameters in here are derived from test result using our accessories. If use other accessories, the test result will be different. Any problem since of using other accessories, we are not able to provide technical support.

### Standard version

Wing loading:140g/dm<sup>2</sup>  
 Wing Area:26 dm<sup>2</sup>  
 Servo:30g digital metal gear servo(1pcs)  
 17g digital metal gear servo(5pcs)  
 9g digital metal gear servo(2pcs)

### 6S Version

Motor:3748-1750KV  
 brushless outrunner motor  
 Ducted fan:90mm 9-blade fan  
 ESC:130A brushless UBEC 8A  
 Empty Weight:2850g(without battery)  
 Thrust:4000g

### 8SVersion

Motor:4075-1250KV  
 brushless Inrunner motor  
 Ducted fan:90mm 12-blade fan  
 ESC:150A brushless UBEC 5A  
 Empty Weight:3120g(without battery)  
 Thrust:5200g

### Other features

Material : EPO  
 Aileron : Yes      Split Flaps: Yes  
 Elevator: Yes      Rudder: Yes  
 Landing gear:Retract landing gear  
 controlled by electric worm  
 Cabin door:nose gear electric cabin door  
 Scale LED lights  
 Scale Pilot figure (2pcs)  
 Battery: 6S 5000-6000mAh (1pcs)  
 8S 4000-5000mAh (1pcs)

## Package list

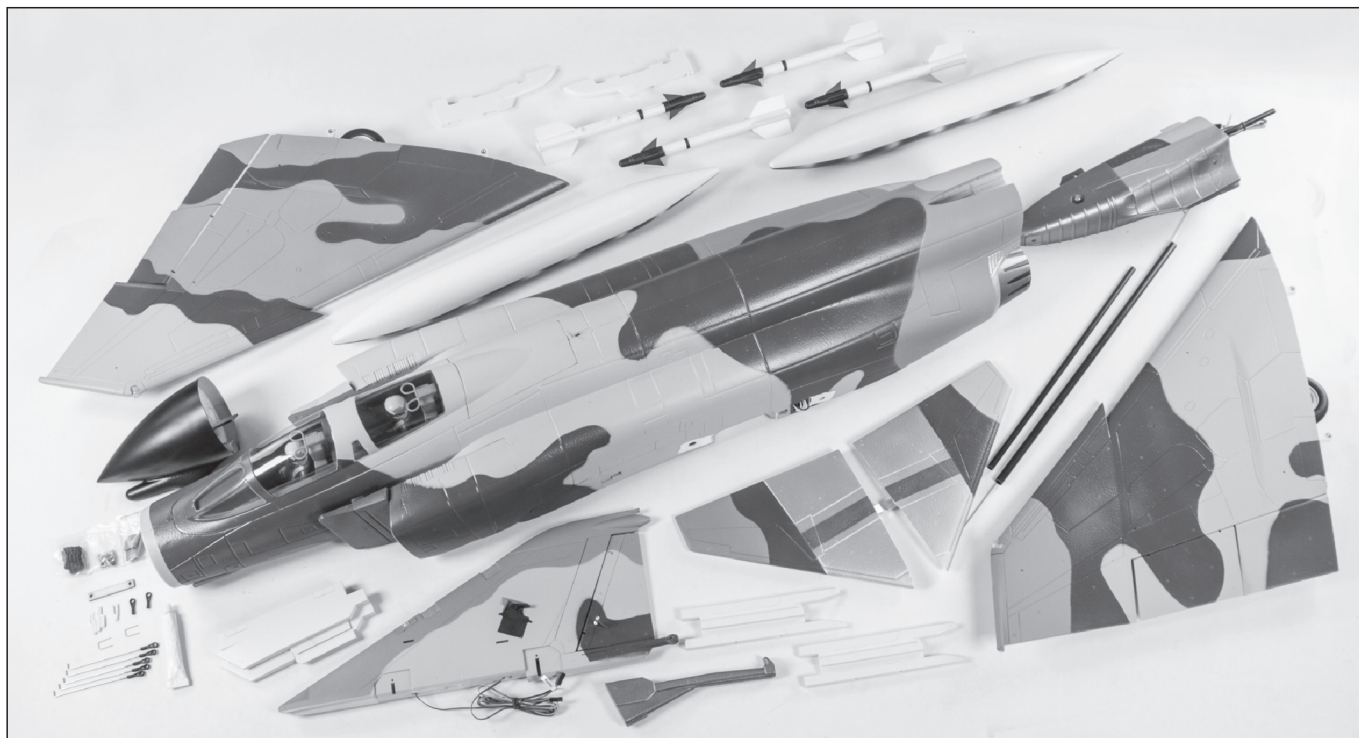

Different equipment include different spareparts. Please refer to the following contents to check your sparepart list.

No.	Name	PNP	ARF Plus	Airframe	No.	Name	PNP	ARF Plus	Airframe
1	Fuselage	Pre-installed all electronic parts	Pre-installed servo	No electronic equipment	7	Pylons & Tail hook	✓	✓	✓
2	Main wing	Pre-installed all electronic parts	Pre-installed servo	No electronic equipment	8	Carbon tube	✓	✓	✓
3	Horizontal tail	✓	✓	✓	9	Pushrod instructions	✓	✓	✓
4	Vertical tail	Pre-installed all electronic parts	Pre-installed servo	No electronic equipment	10	Non-slip mat & Glue	✓	✓	✓
5	Drop tank	✓	✓	✓	11	Decals & Manual	✓	✓	✓
6	Drop tank & Missiles	✓	✓	✓	12	Screw	✓	✓	✓

## Traction steel wire use instruction

To minimize servo connections, the Elevator and Rudder servos' wires each reach from the servo itself directly to the receiver. A rigid steel wire hook is included in the box to allow you to pull the servo wires through the model's internal fuselage.



## Install Fuselage

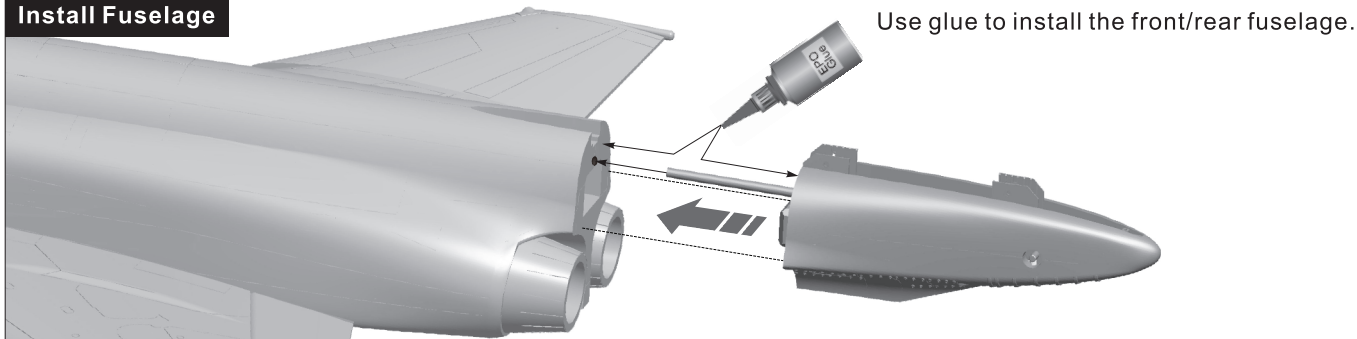

Use glue to install the front/rear fuselage.

## Install Horizontal Stabilizer

As shown in the photo below:

1. Use screws to install the left/right horizontal stabilizer on the rear fuselage. (Appropriate Screw Adhesive can also be used, if desired)
- Attention:** Left elevator and right elevator should keep the same level, then fix the screws.
2. Use the included rigid steel wire hook to pull the elevator servo cable through the upper chamber forward to the battery compartment.
3. Use 3pcs screws to attach Foam Cover C onto the rear fuselage.
4. Use glue to attach the arresting hook onto Foam Cover C.

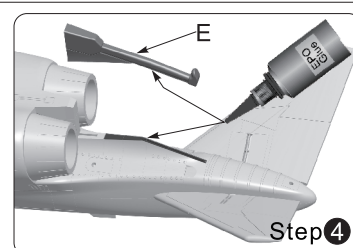

- A- Horizontal Stabilizer
- B- Set screw (M4x4 2pcs)
- C- Foam Cover
- D- Screw (PA3x8 3pcs)
- E- Tail hook

Step 3

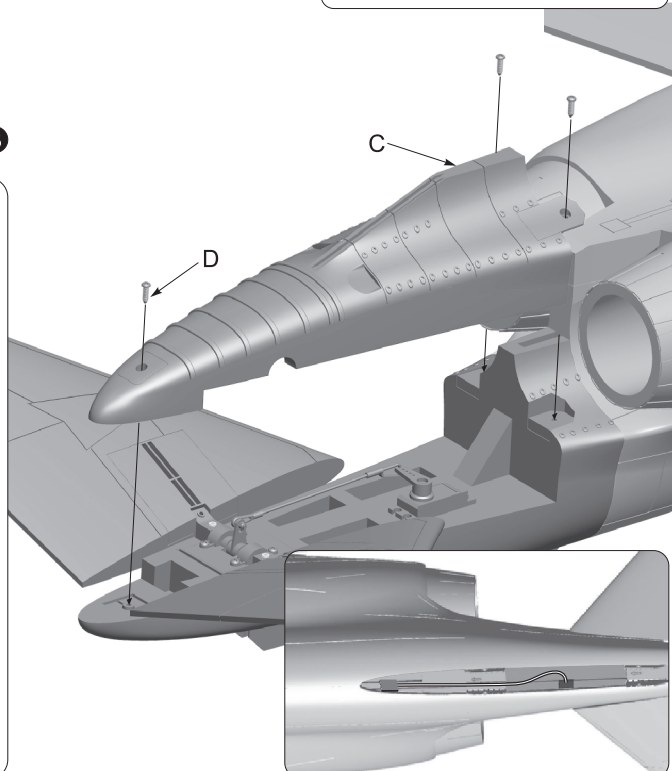
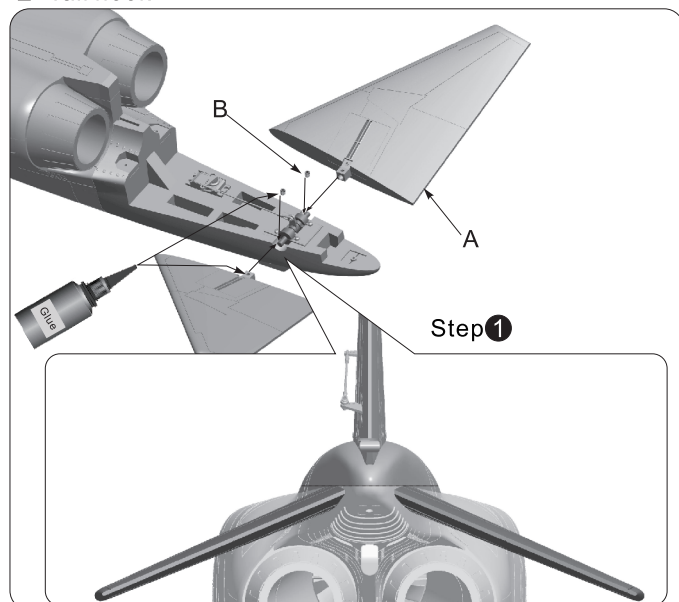

Step 2

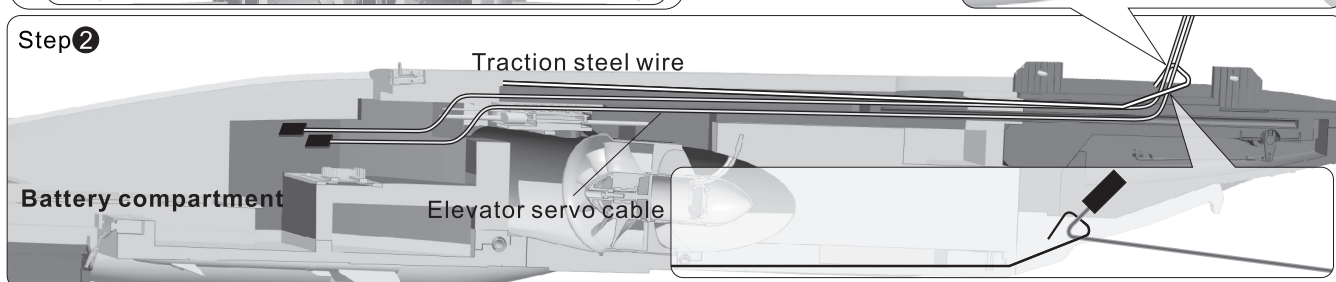

## Install Vertical Stabilizer

As shown in the photo below:

1. Use U-buckle to fix the rudder servo cable.  
(Slightly press U-buckle into the rudder.)
2. Use a rigid steel wire hook to pull the rudder servo cable to the battery compartment;
3. Install the vertical stabilizer on the rear fuselage;
4. Then use 4pcs screws to fix.

- A- U-buckle
- B- Rudder servo cable
- C- Rudder
- D- Screw (KA3x10 4pcs)

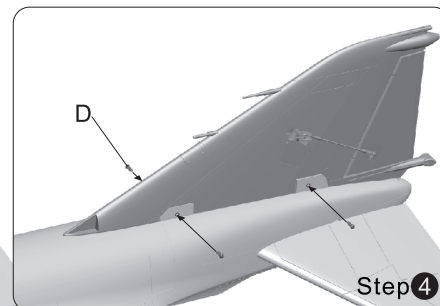
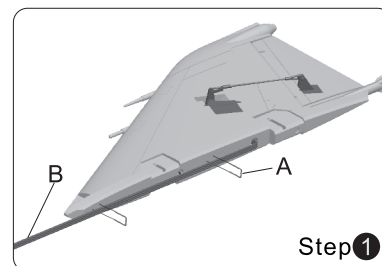

Step 3

Step 2

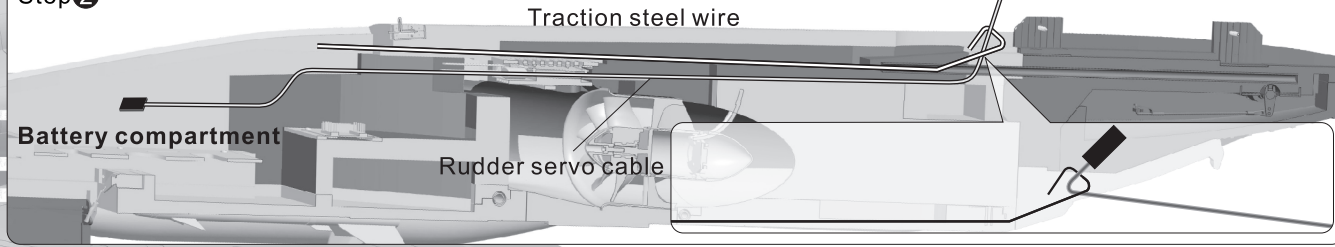

## Install Main wing

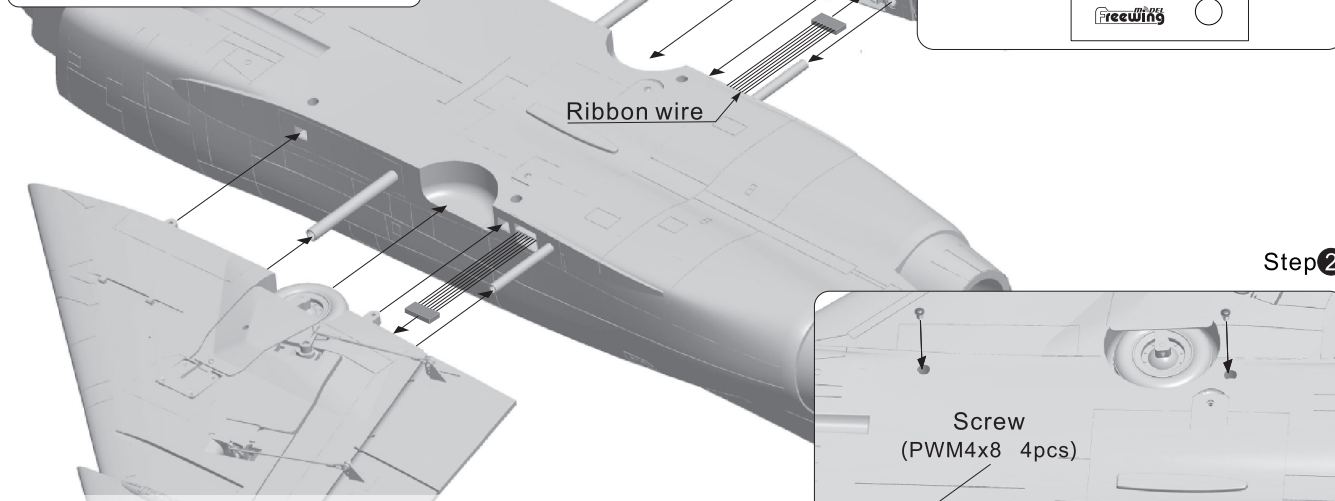
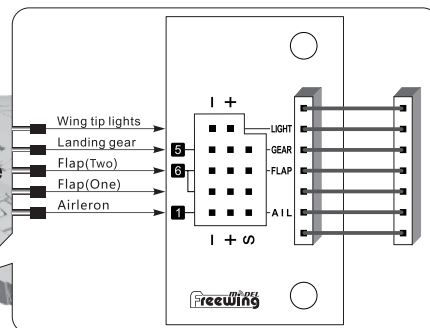
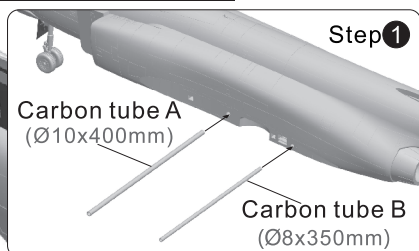

Step 2

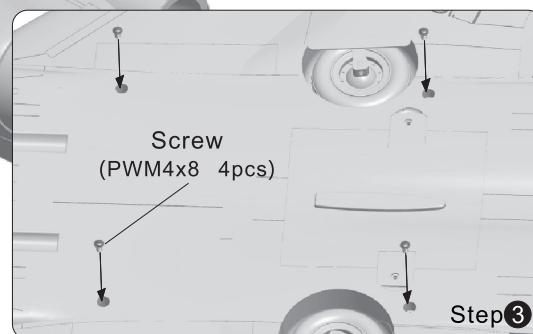

1. Insert the carbon wing spars A and B into the fuselage mounting tubes.
2. Plug the ribbon wire into the wing controller module, then install the left/right main wing onto the fuselage.
3. Use 4pcs screws to secure the main wing.

## Install Scale Accessories

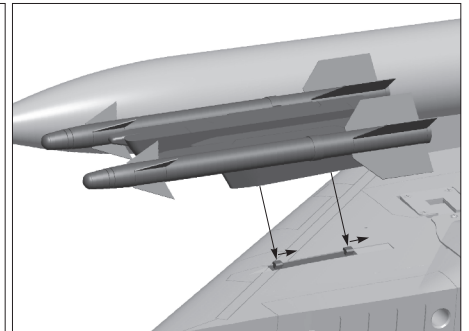
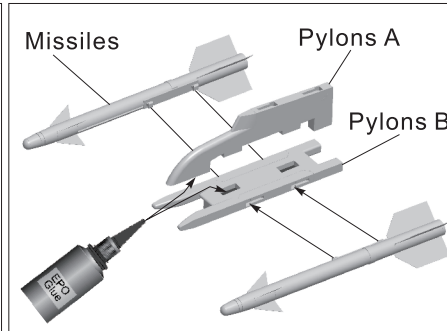
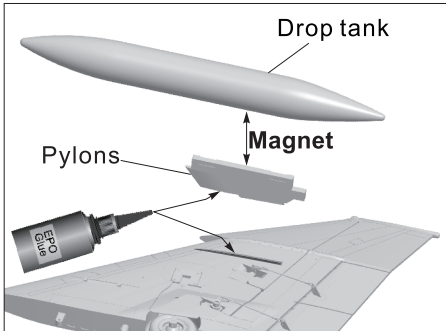
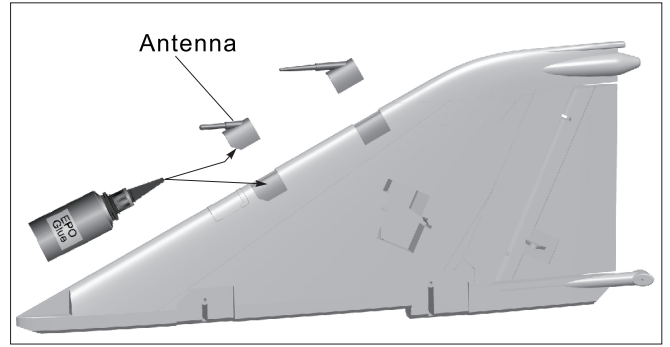
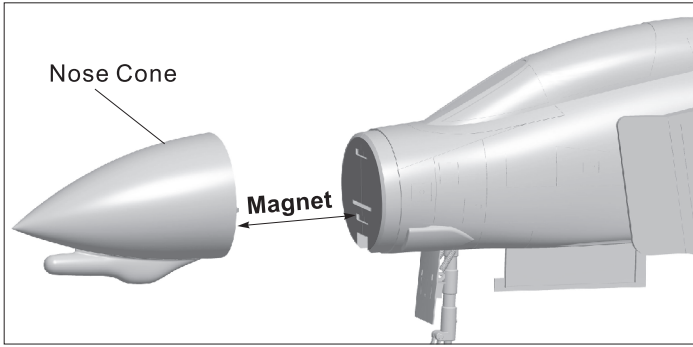

## Pushrod instructions

### Nose gear steering pushrod length

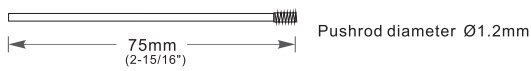

### Nose gear steering pushrod mounting hole



### Flap pushrod length

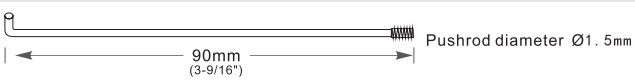

### Flap pushrod mounting hole



### Aileron pushrod length



### Aileron pushrod mounting hole

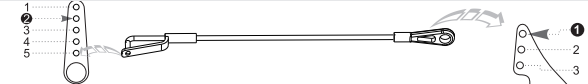

### Elevator pushrod length



### Elevator pushrod mounting hole



### Rudder pushrod length

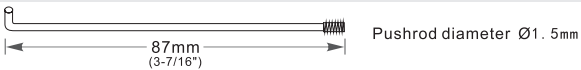

### Rudder pushrod mounting hole

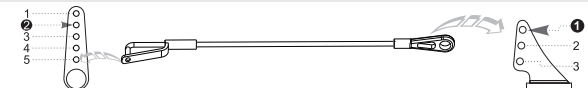

## Control board connection diagram

The F-4 uses a convenient flexible ribbon wire harness to consolidate wiring. Connect according to the photo.

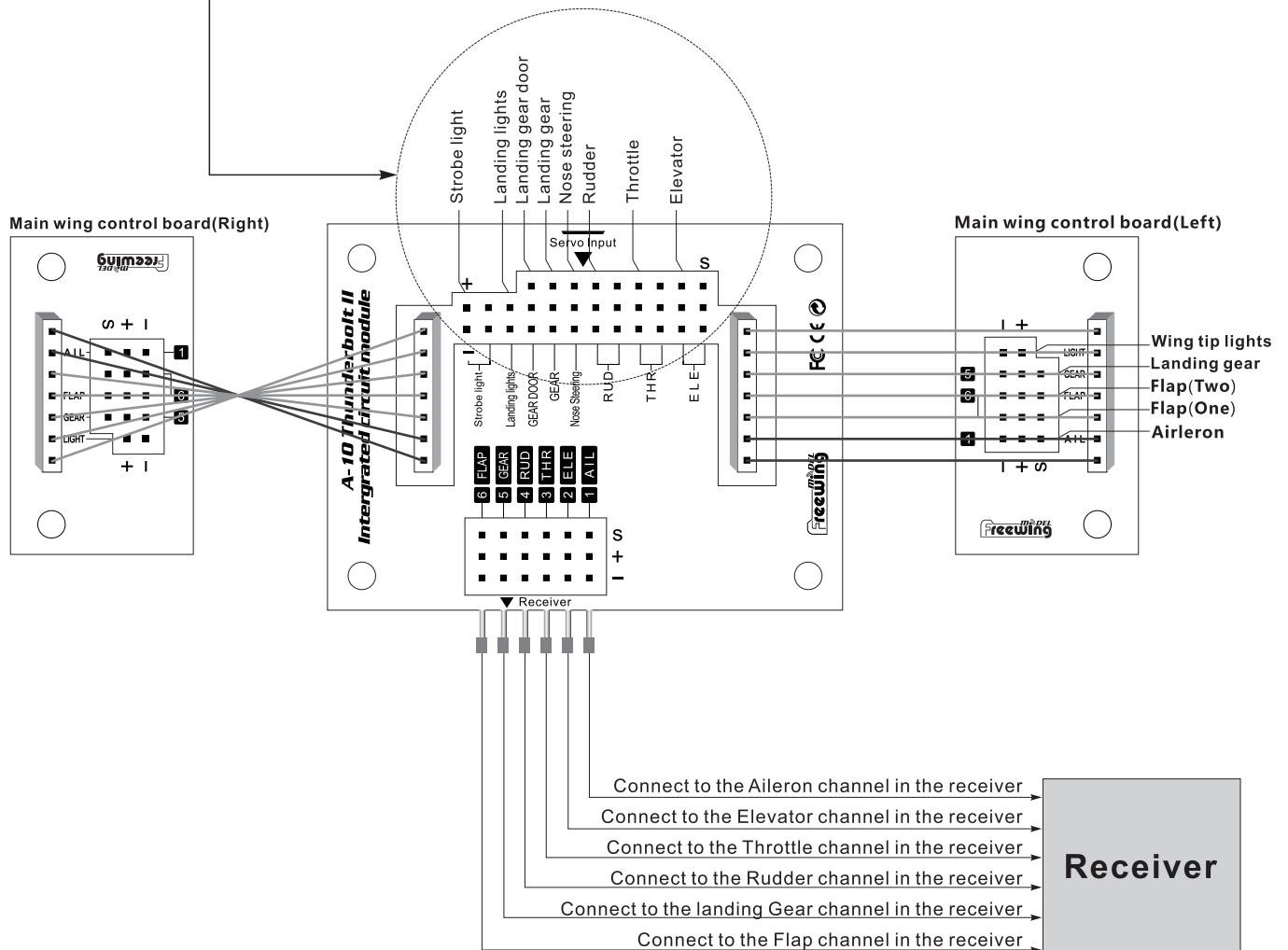
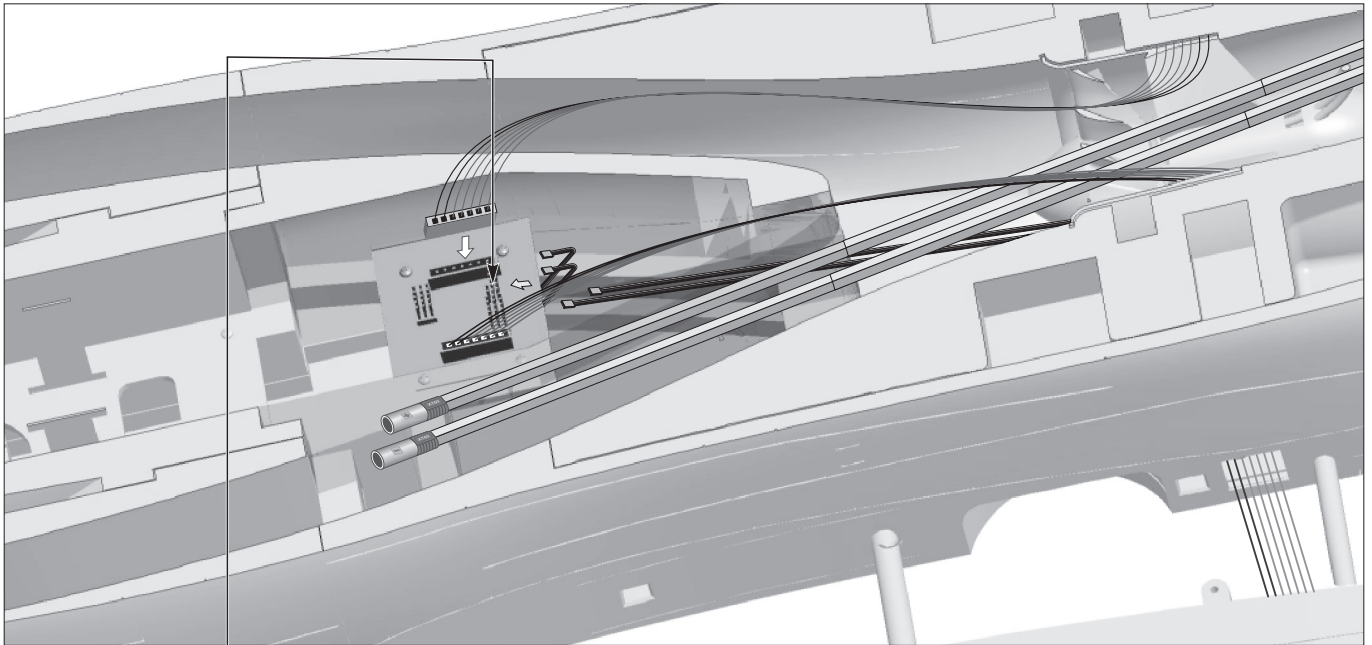



## Battery Size

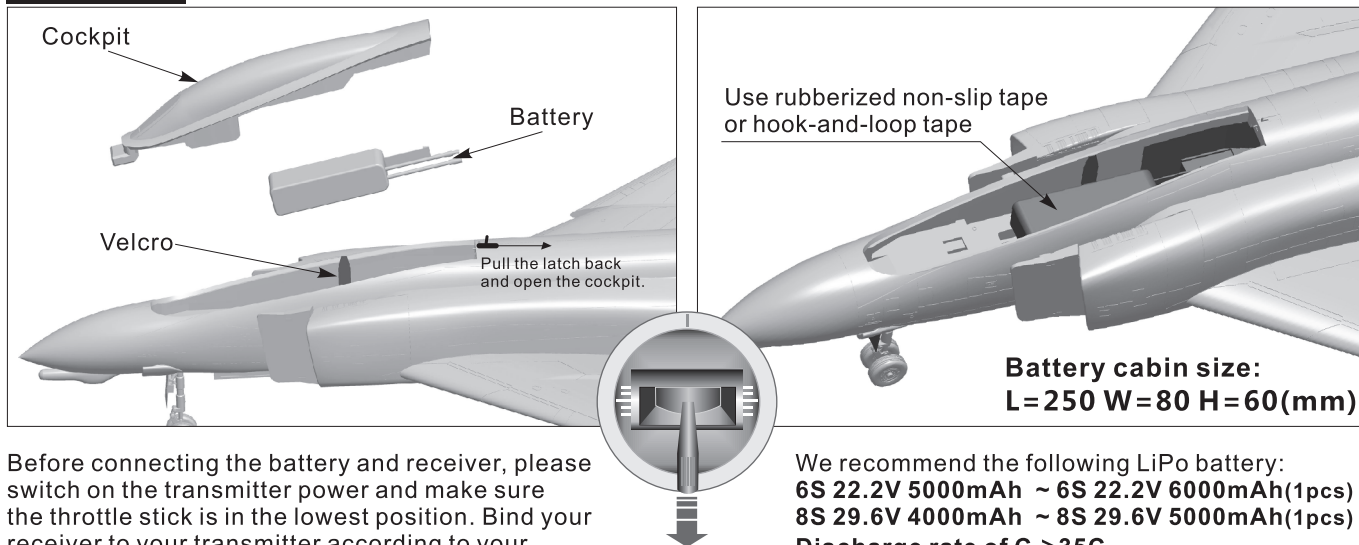

**Battery cabin size:  
L=250 W=80 H=60(mm)**

Before connecting the battery and receiver, please switch on the transmitter power and make sure the throttle stick is in the lowest position. Bind your receiver to your transmitter according to your transmitter's instruction manual.

We recommend the following LiPo battery:  
**6S 22.2V 5000mAh ~ 6S 22.2V 6000mAh(1pcs)**  
**8S 29.6V 4000mAh ~ 8S 29.6V 5000mAh(1pcs)**  
**Discharge rate of C ≥35C**

## Center of Gravity

Correct Center of Gravity ( CG" ) is critical for enabling safe aircraft stability and responsive control. Please refer to the following CG diagram to adjust your aircraft's Center of Gravity.

- Depending on the capacity and weight of your chosen flight batteries, move the battery forward or backward to adjust the Center of Gravity.
- If you cannot obtain the recommended CG by moving the battery to a suitable location, you can also install a counterweight to achieve correct CG. However, with the recommended battery size, a counterweight is not required. We recommend flying without unnecessary counterweight.

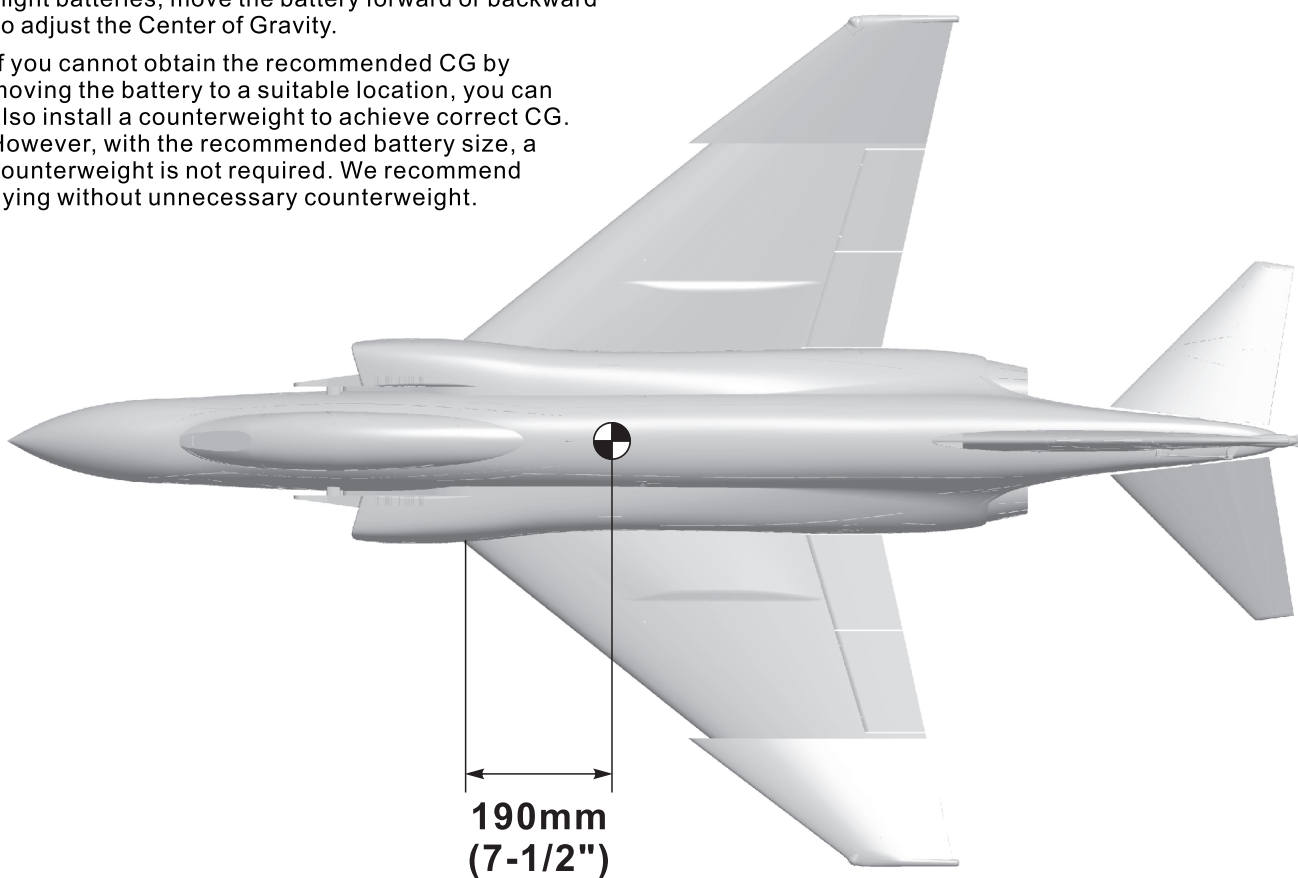

## Servo Direction

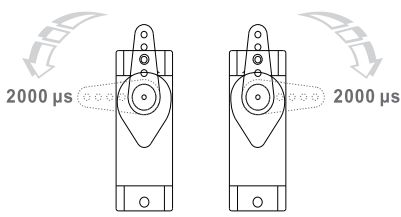

The servo positive or reverse rotation is defined as follows:  
 When servo input signal change from 1000μs to 2000μs,  
 The servo arm is rotated clockwise, its positive servo.  
 The servo arm is rotated counterclockwise, its reverse servo.

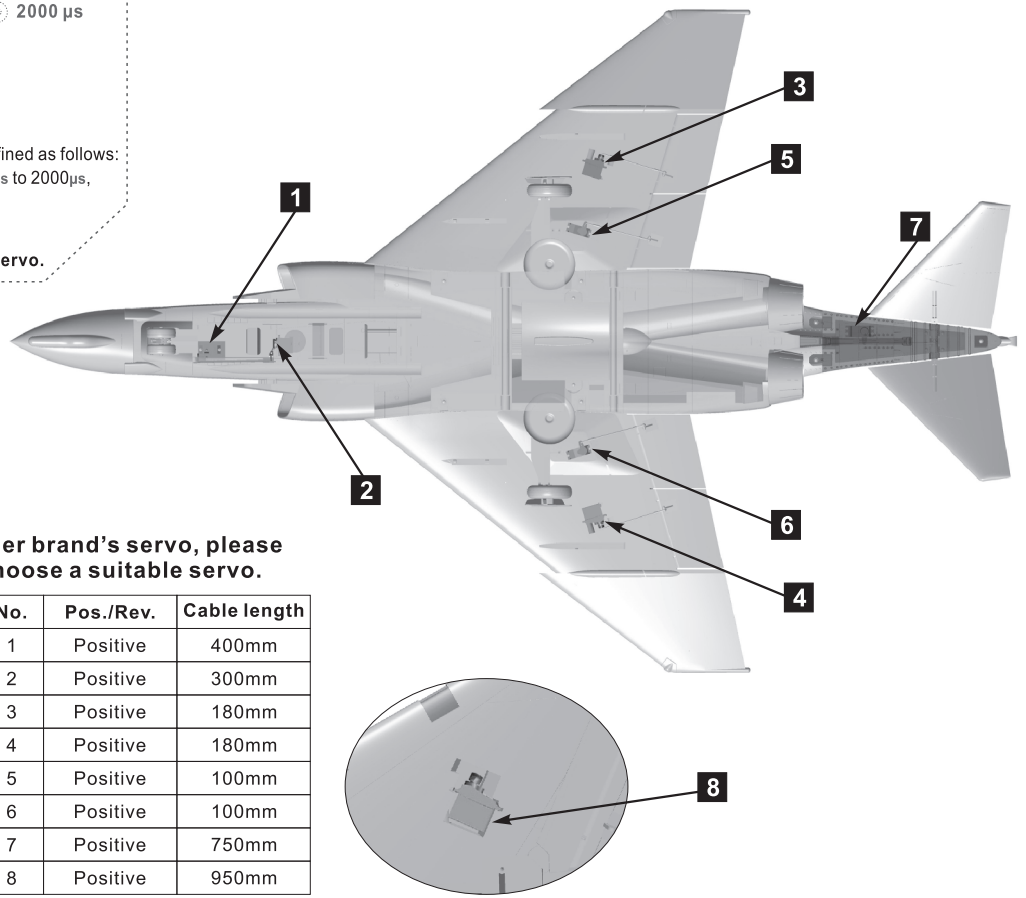

If you need to purchase another brand's servo, please refer to the following list to choose a suitable servo.

Position	Servo regulation	No.	Pos./Rev.	Cable length
Nose gear steering servo	9g Digital-MG	1	Positive	400mm
Nose Landing gear door	9g Digital-MG	2	Positive	300mm
Aileron(L)	17g Digital-MG	3	Positive	180mm
Aileron(R)	17g Digital-MG	4	Positive	180mm
Flap(L)	17g Digital-MG	5	Positive	100mm
Flap(R)	17g Digital-MG	6	Positive	100mm
Elevator	30g Digital-MG	7	Positive	750mm
Rudder	17g Digital-MG	8	Positive	950mm

## Motor Specification

Item No.:MO037484  
**3748-1750kv**

Item No.:MI040752  
**4075-1250kv**

Item No.	Use motor	Motor(KV)	Thrust(g)	Current(A)	Use voltage (V)	Use ESC (A)	EDF Weight (g)	Max power (W)	Efficiency (g/w)
E7228	<b>MO037484</b> 3748-1750KV	1750	4000	100	22.2(6S)	130	378	2200	1.82
E7227	<b>MI040752</b> 4075-1250KV	1250	5200-5400	100-110	29.6(8S)	150	600	3110	1.7

## Control Direction Test

After installed the plane, before flying, we need a fully charged battery and connect to the ESC, then use radio to test and check that every control surface work properly.

### Aileron

Stick Left

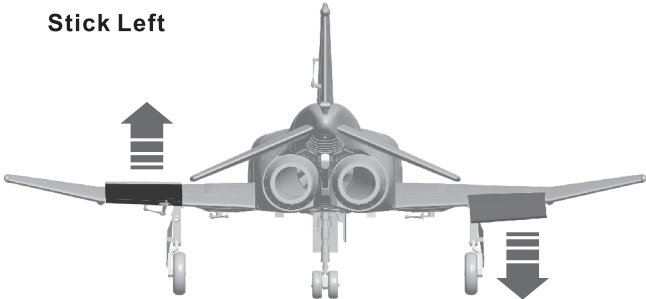

Stick Right

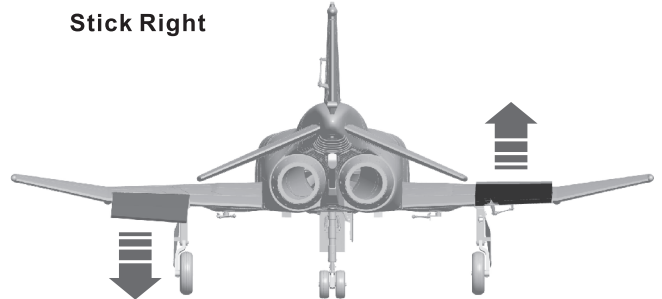

### Elevator

Stick down

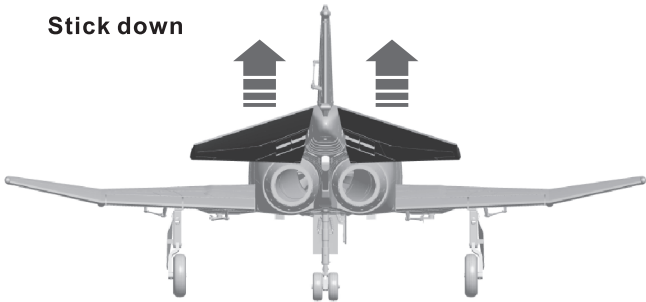

Stick Up

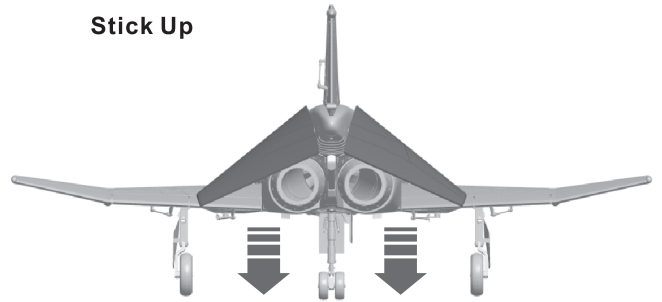

### Rudder

Stick Left

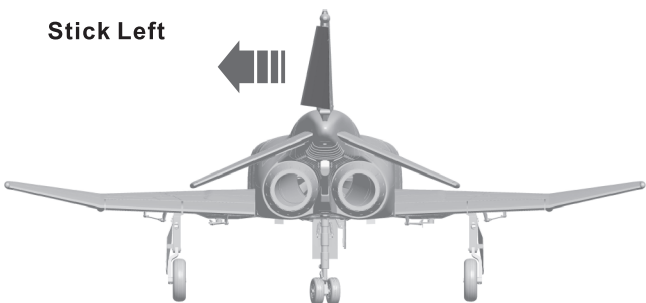

Stick Right

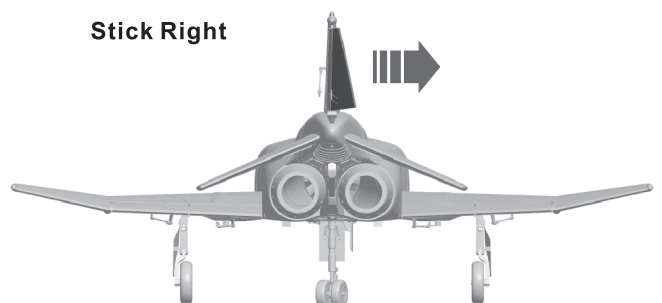

### Flaps

Flaps down

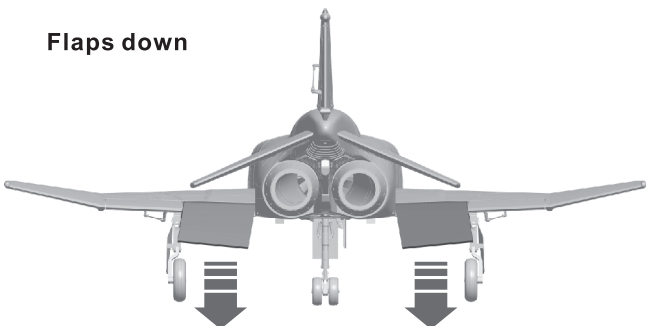

## Dual Rates

According to our testing experience, use the following parameters to set Aileron/Elevator Rate. Program your preferred Exponential % in your radio transmitter. We recommend using High Rate for the first flight, and switching to Low Rate if you desire a lower sensitivity. On successive flights, adjust the Rates and Expo to suit your preference.

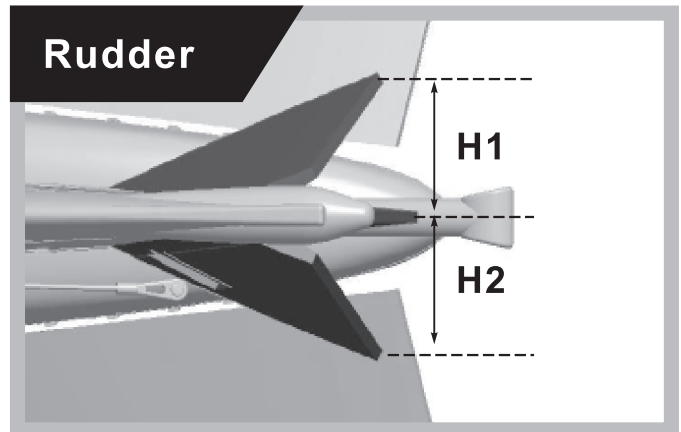
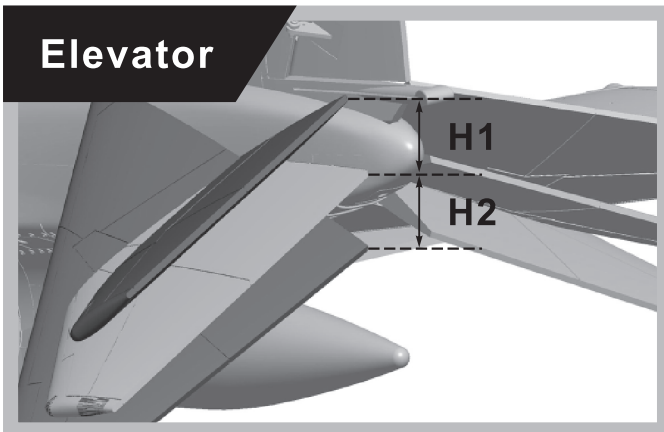
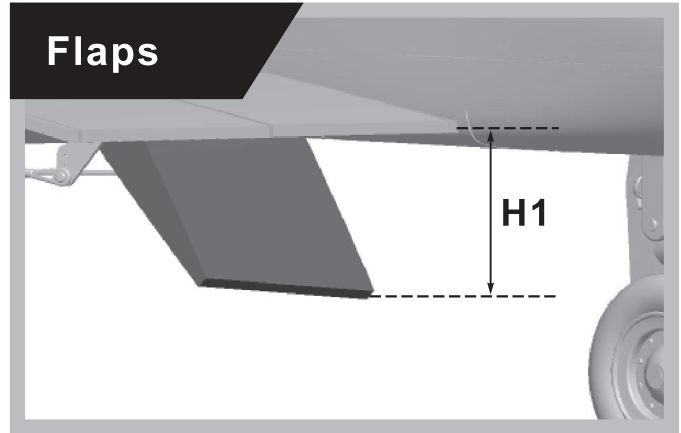
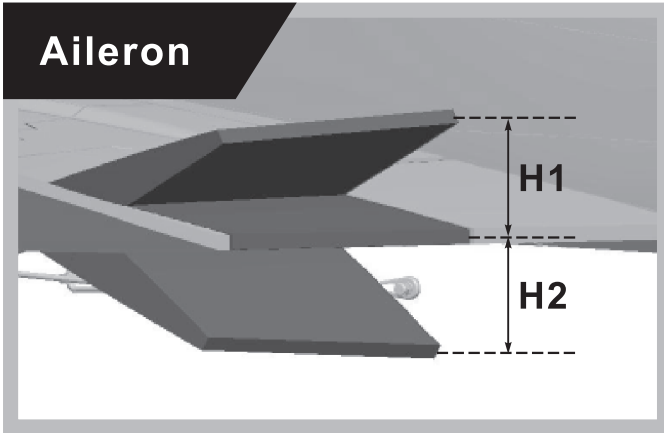

	Aileron(measured closest to the fuselage)	Elevator(measured closest to the fuselage)	Rudder(Measured from the bottom)	Flaps
<b>Low Rate</b>	H1/H2 27mm/27mm D/R Rate : 80%	H1/H2 27mm/27mm D/R Rate : 80%	H1/H2 42mm/42mm D/R Rate : 80%	H1 25mm
<b>High Rate</b>	H1/H2 32mm/32mm D/R Rate : 100%	H1/H2 31mm/31mm D/R Rate : 100%	H1/H2 48mm/48mm D/R Rate : 100%	H1 45mm

### ⚠ Important Flight Notes:

- A Flap-to-Elevator Mix is required to maintain level flight when the flaps are deployed.  
The detail is as below:  
**With high rate flaps deployed, mix 5mm of UP elevator.**  
**With low rate flaps deployed, mix 3.5mm of UP elevator.**
- Before flying, adjust the elevator's center position according to the right photo.

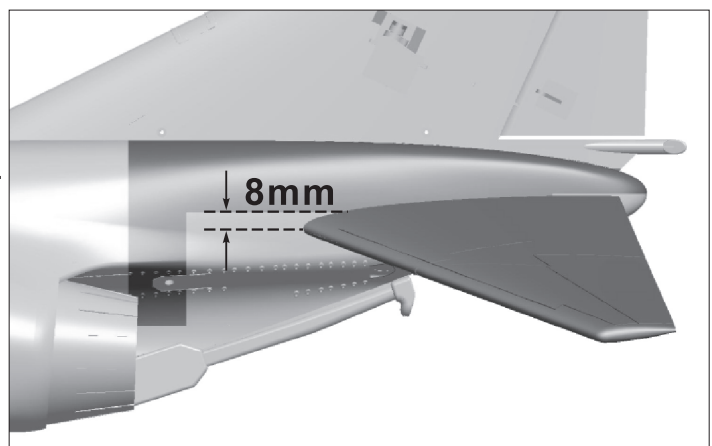



**Dongguan Freewing Electronic Technology Ltd**  
**HK Freewing Model International Limited**

Add.: Fei Yi Building, face to Labor Bureau, Fumin Middle Road, Dalang Town,  
Dongguan City, Guangdong Province, China

Web: <http://www.sz-freewing.com>

Email: [freewing@sz-freewing.com](mailto:freewing@sz-freewing.com)

Tel: 86-769-82669669 Fax: 86-769-82033233

**东莞市飞翼电子科技有限公司**  
**香港飞翼模型国际有限公司**

地址: 广东省东莞市大朗镇富民中路402-408号飞翼楼四楼

Web: <http://www.sz-freewing.com>

Email: [freewing@sz-freewing.com](mailto:freewing@sz-freewing.com)

Tel: 86-769-82669669 Fax: 86-769-82033233

