



J-3 CUB

1/6 Scale SIGRC3



BUILDING and FLYING INSTRUCTIONS

This model of the famous Piper Cub is a natural for radio control, but can also be flown free flight - an increase in dihedral is recommended for this application - or converted to control line by the addition of leadout guides to the wing tip and a bellcrank in the cabin. The stable flight characteristics make it a good RC scale trainer for inexperienced fliers, but it can be stunted by expert expert pilots. Built-up construction is strong and light, will not be difficult if you study the plans and the instructions in this manual carefully. Read all of the manual before beginning construction.

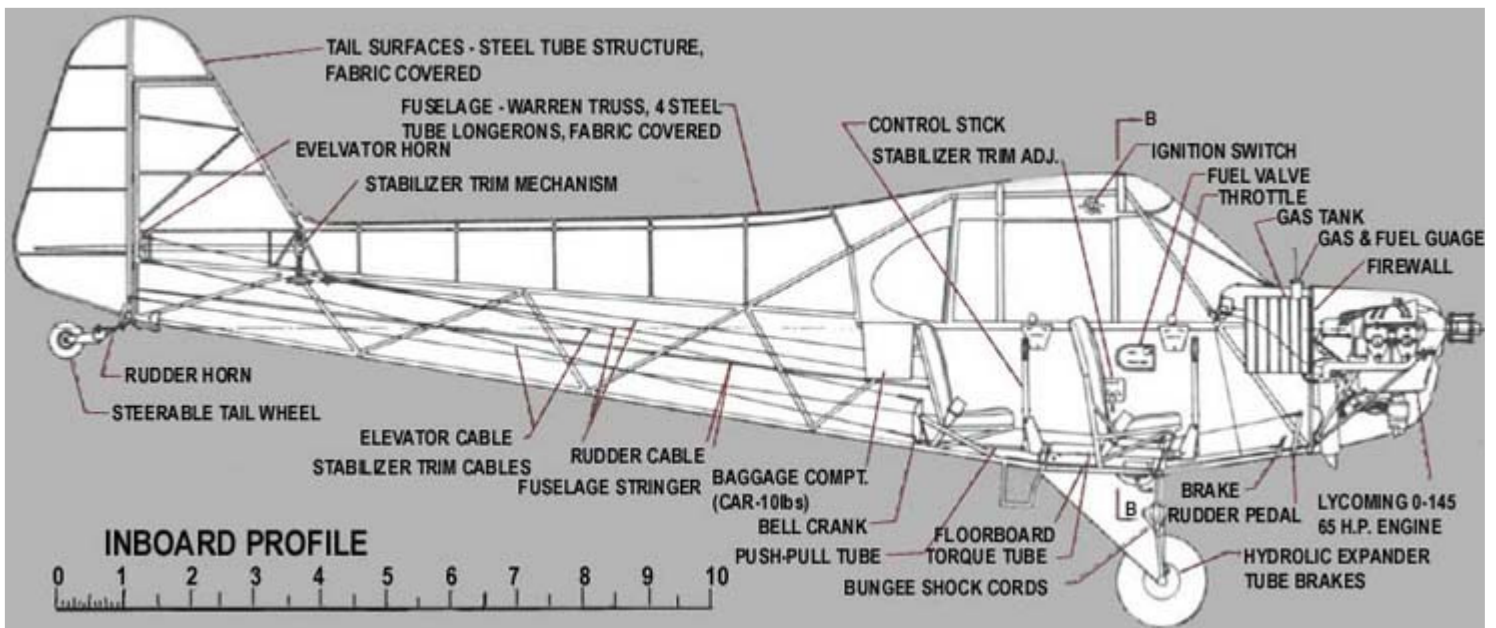

Die-cut parts are marked with letters indicating the particular component - "F" for fuselage, "W" for wing and "S" for stabilizer. Leave the parts in the sheet until needed for construction so that they will not be lost or broken. Remove the pieces from the sheets carefully. If difficulty is encountered, do not force the part from the sheet. Use a modeling knife to cut it free.

Wax paper may be used to protect the plan during building when the glue used is an aliphatic resin such as Sig Bond, a white variety such as Sig Superweld or Sig Epoxy. If a model cement like Sig-Ment is selected, use plastic wrap to protect the drawing because this type of glue will dissolve the wax out of the wax paper and not set up properly.

1. WING PANELS

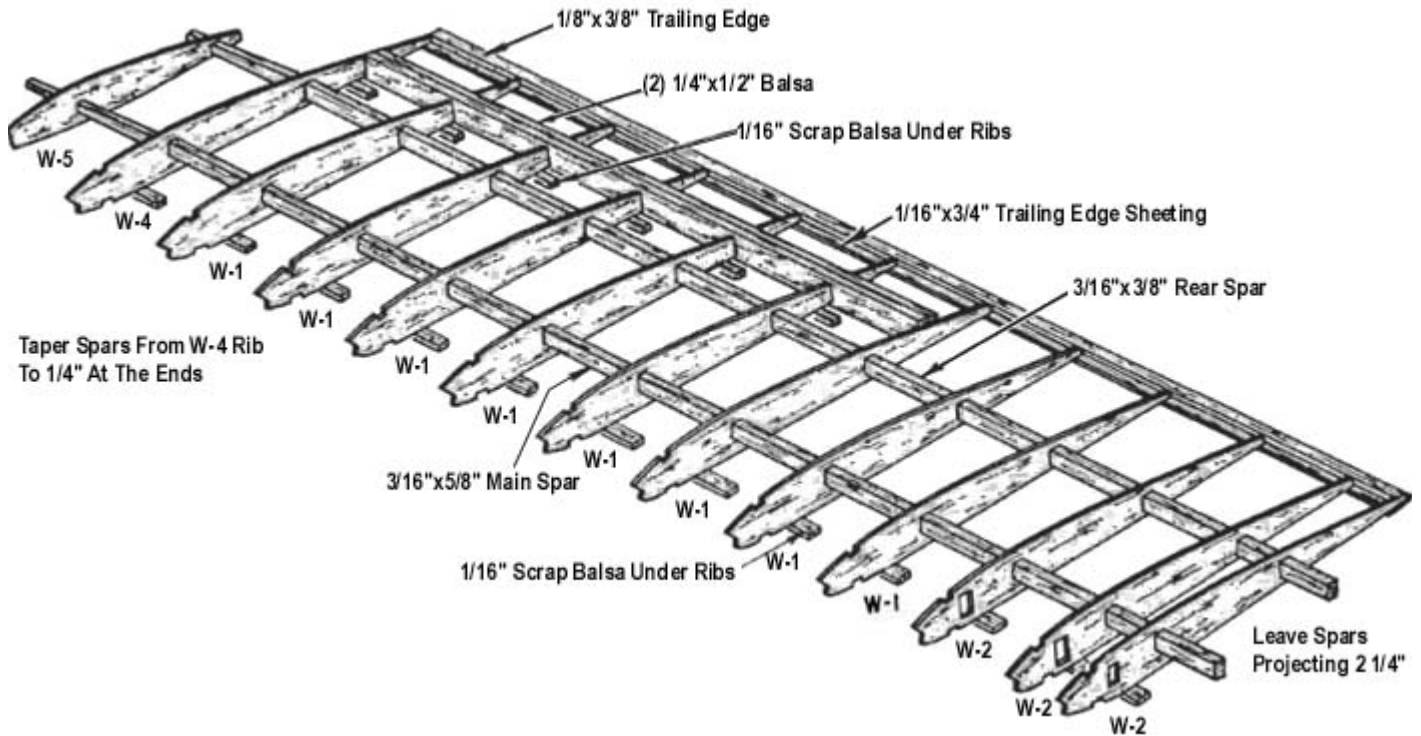

A. Laminate two 1/8" thick W-6 pieces together to make a single 1/4" thick. Do the same with W-7 and W-8. Assemble W-6, W-7 and W-8 into a complete wing tip by gluing together flat on the plan. Remove when dry.

B. Pin the 1/16"x3/4" trailing edge sheeting over the plans and glue the 1/8"x3/8" shaped trailing edge on top of the 1/16"x3/4" sheeting in the position indicated on the plans.

C. Look at the Aileron Construction View and the Aileron Rib Cross-section. Note the 1/8"x1/4" piece of balsa - indicated by gray tone on the isometric drawing - on the back of the 1/4"x1/2" piece that forms the leading edge of the aileron. This is cemented on 1/16" up from the bottom. Pin the 1/4"x1/2" aileron leading edge piece and the 1/4"x1/2" piece just ahead of it that forms the back of the wing in place on the plan.

D. Taper the main and rear spars from full height at Rib W-4 to 1/4" tall at the tip ends of the spars. Take all of the taper off on the top of the spars.

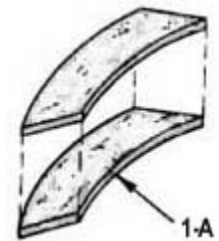

Aileron Rib Cross-Section



E. Thread the wing ribs over the spars. If any of the spar holes are too tight, do not try to force the rib onto the spar but enlarge the hole slightly so that it will slip over the spar easily. For spars which may have a natural bow, the height of the spar holes should be increased so that the spar can be accommodated in the rib with the rib sitting flat on the building surface.

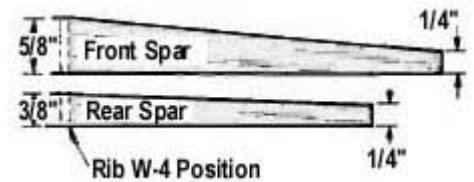

F. Use 1/16" scrap balsa scabs under each rib, front and rear, on the flat bottom before the upward curve starts. This will bring the rib-spar assembly on a level with the trailing edge planking.

G. Place the rib-spar assembly over the plans, align the ribs and pin down.

H. Glue ribs with Sig Super Weld to the 1/8"x3/8" shaped trailing edge and to the 1/4"x1/2" piece that forms the front of the aileron cavity in the wing.

I. Glue the "A" ribs in place in the ailerons between the 1/4"x1/2" aileron leading edge piece and the 1/8"x3/8" shaped trailing edge. Use temporary scabs of 1/16" scrap balsa under the front of the A ribs to bring them level with the trailing edge plankin. (See Aileron Rib Cross-section).

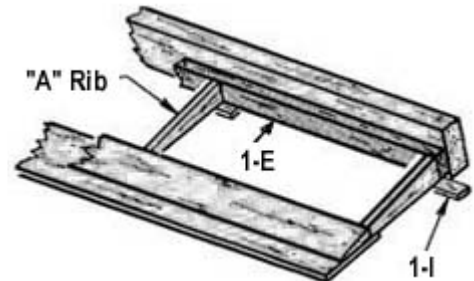

J. Add the 5/16" square leading edge.

K. Glue in the 1/8"x1/4" top front spar with Super Weld.

L. Install all W-3 half ribs by inserting sideways under the top front spar and twisting into place on the leading edge and the top front spar. The last W-3 rib at the wing tip must be modified slightly to fit over W-8 and is not installed until W-8 is in place.

M. Bevel the edge of the 1/16" sheet trailing edge top planking so that it will fit snugly against the trailing edge bottom planking and glue in place.

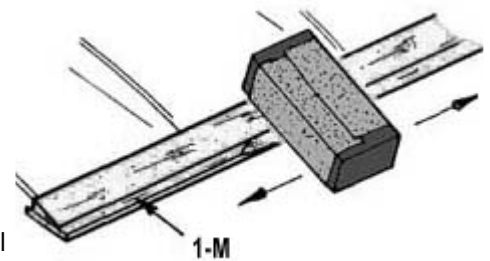

N. Glue the preassembled wing tip assembly (Paragraph A in this section) in place. Block up with scrap balsa to the level of the 1/4" ends of the main and rear spar and cement tip to them as well as the leading and trailing edge.

O. Insert the top front spar into W-8 and taper W-8 so that the 1/16" top planking will join smoothly when installed, a matter of cut and try.

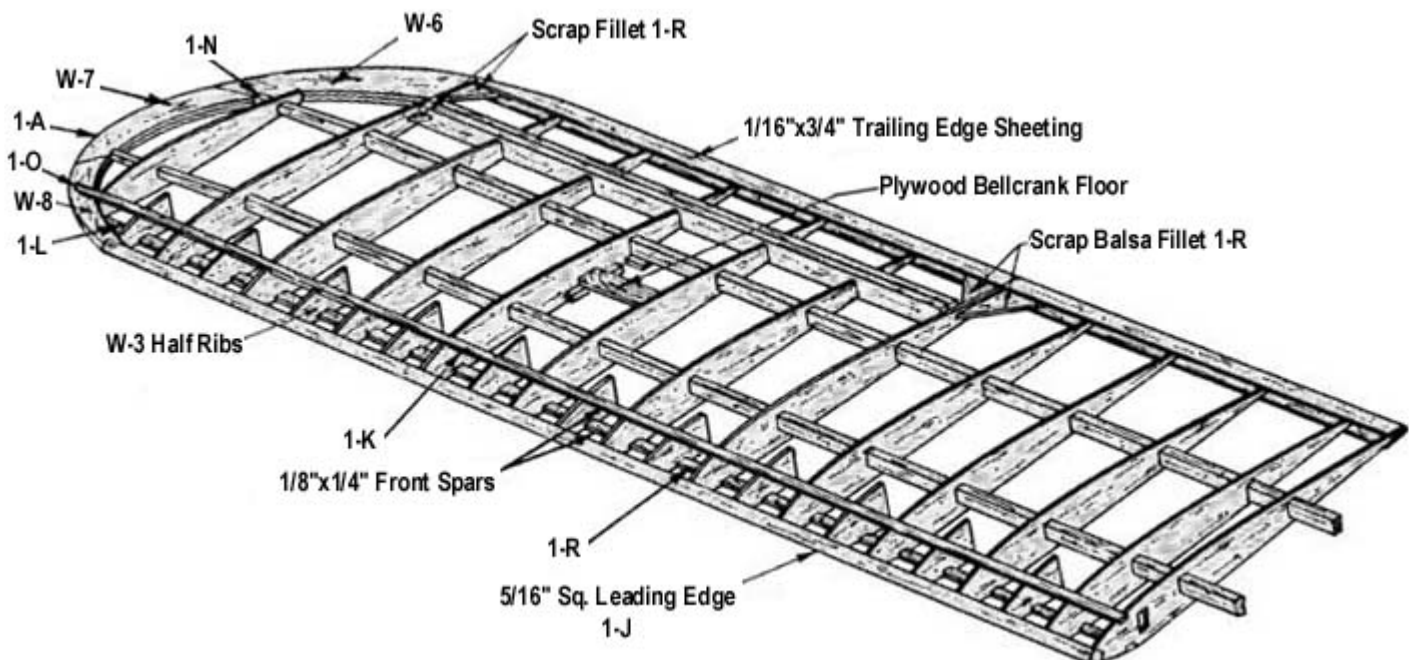

P. Add the 1/16" sheet front planking.

Q. Put the 1/16"x1/8" capstrips on top of all ribs, including the aileron, except for the two end W-2s and W-5.

R. Remove wing panel from the plan. The 1/8"x1/4" bottom front spar should be inset into W-8 as was the top front spar. Install gussets made from die cut sheet scrap. In addition to the gussets in the wing shown on the plan, it is recommended that scrap gussets also be added to the corners of the ailerons. This will prevent covering shrinkage from distorting the aileron end ribs. Note the proper direction of the grain for the gussets as shown on the plan.

S. Use scrap plywood for the anchor blocks in the wing that provides places to fasten the strut ends and holes in which to plug the strut braces. Block them out from the spars with scrap balsa so that the plywood is flush with the surface wing.

T. The plywood mounting plate for the aileron control horn is installed flush with the bottom surface. Install the aileron control horn before the wing is covered, epoxying the nylon screw retainer securely to the inside of the plywood plate so that the control horn may be removed to get it out of the way for the covering operation and later re-installed.

U. The plywood mounting for the aileron bellcrank should be re-inforced with 1/4" square scrap balsa at each end where it contacts the wing rib. You may wish to build an opening from scrap balsa around the point where the R/C clevis link rod exits from the wing surface between the bellcrank and control horn. This will make a neater job and provide a place to fasten the covering.

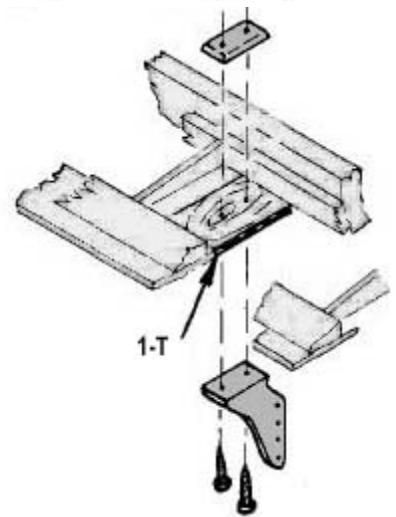
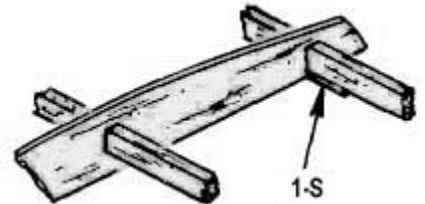
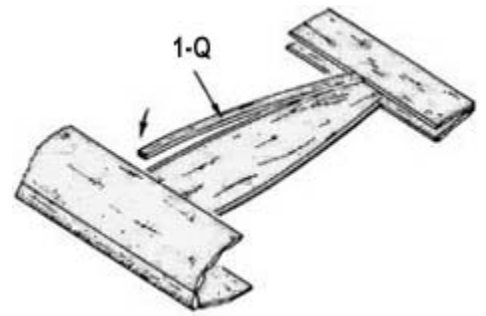

No Capstrips on the bottom of the last rib (W-5)

1/16"x1/8" Capstrips (Top and Bottom)

1/16"x3/4" Trailing Edge Sheeting

1/16" Sheeting (Top and Bottom)

1/16" Sheeting (Top and Bottom)

Round off Leading Edge with sandpaper

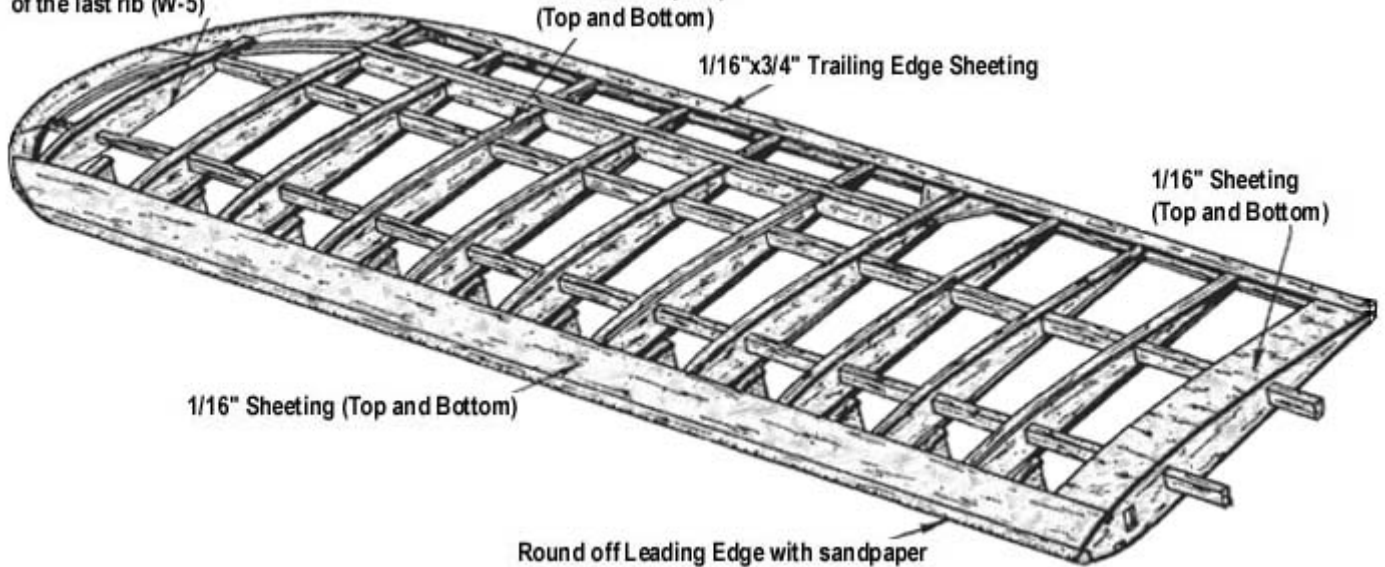

2. WING CENTER SECTION

- A. Prepare the center section trailing edge in the same manner as the wing.

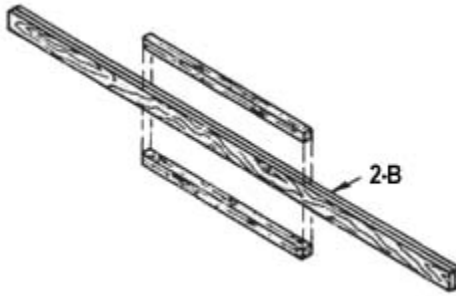

- B. Assemble the plywood wing joiners. Then add 1/4" square balsa pieces as shown in the accompanying sketch.

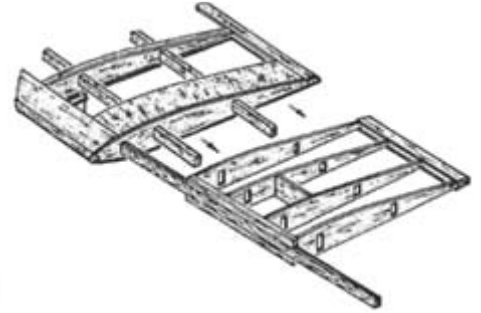

- C. Lay the four center ribs over the plan with 1/16" scrap scabs under the fronts to level them with the trailing edge planking. Glue the two middle ribs of the center section to the trailing edge and the plywood wing joiners. Leave the outer ribs unglued for the moment and hold them in position with pins.
- D. Slide the spars of the completed wing panels into the holes of the center section ribs and the plywood wing joiner ends into the holes of the W-2 ribs of the wing panel. Block up each tip 7/16", measured at rib W-4. This procedure will necessitate enlarging the bottoms of the plywood wing joiner holes in the W-2 ribs and the bottoms of the spar holes in the center section ribs to permit the swiveling action needed to incorporate the dihedral. If you are planning to fly the Cub by rudder only control it is recommended that you increase the amount of dihedral under each tip to one inch. For free flight Cub, put 2" of dihedral under each tip.
- E. Epoxy the spars together and re-inforce the joints with scrap plywood. Use epoxy also on the trailing edge joints to the center section. Glue the outer center ribs up against the ends of the wing panels and to the plywood wing joiners. Sheet the center section with 1/16" balsa.
- F. Fill all dents and cracks with Sig Epoxolite putty. Sand entire wing carefully with a sanding block and finish with hand-held fine sandpaper.
- G. Control surfaces are attached with molded nylon hinges provided in the hardware pack.

3. WING STRUTS (See Plan)

The front strut for the J-3 Cub is approximately 21" long. The rear strut is approximately 21-1/2" long. Individual construction differences between models can cause variations in the lengths required, so measure for exact size directly on your model with the wing permanently installed. Sand strut to airfoil shape.

Drill two holes in the aluminum shim stock where it will be inside the spruce wing strut. These holes will enable the epoxy glue to get a good grip on the aluminum. Cut a slot in the end of the strut with a razor saw, and epoxy the aluminum strip into the slot. Wrap a piece of fine cloth (silk or fiberglass), coated with epoxy, around the end of the strut to reinforce the installation of the aluminum.

Screws are provided to fasten the upper wing strut ends to the plywood strut attachment plates that are built into the wing. Bolt and nuts are provided for connecting the lower wing strut ends to the shim aluminum fittings that are built into the fuselage above the landing gear.

Glue piece of 1/16"x1/8" balsa to the "U" shaped 1/16" wire strut braces. Cover with paper or silk to firmly attach to the wire.

An alternate popular method for the construction of the strut ends is shown on the plan. The materials for these modifications are not furnished in the kit. Molded nylon pinned hinges are shown for the upper strut ends to enable them to fold flat against the bottom surface of the wing when it is removed for transportation or storage. For the fuselage end of each strut an adjustable RC clevis can be used to provide quick detachability.

4. ELEVATOR AND STABILIZER

A. Laminate two S-1 pieces to make a single piece 1/4" thick. Do the same with pieces S-2 through S-6.

B. Protect the plan with wax paper. Pin down and glue together with Sig Bond, pieces S-1 through S-6.

C. Note that the two halves of the elevator are joined by a piece of 1/4" dowel which is built into the structure at this time.

D. Add the 1/4" square balsa trailing edge of the stabilizer, leading edge of the elevator and the end pieces.

E. Ribs are 2/32" x 1/4" balsa.

F. The stabilizer is not covered until after installation on to the two fuselage dowels. There is a gap between the fuselage and the stabilizer frame to simulate the same effect in the real airplane.

G. Sand all edges round. Do not airfoil the tail surfaces as the original was made of tubing and was flat.

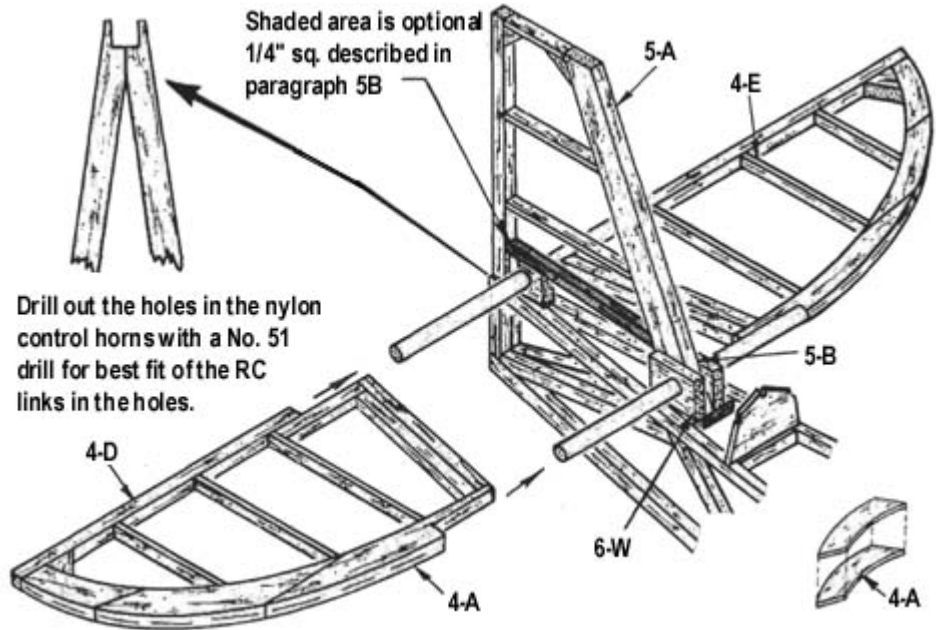

5. FIN AND RUDDER

A. The fin and rudder are constructed similar to the stabilizer and elevator, except that the outline is formed of 1/4" x 1/2" balsa sticks rather than laminated die cut shapes.

B. The plan duplicates the scale structure of the fin on the full size Cub and thus has no rib at the bottom of the fin. The covering is stretched from the lower 3/32" x 1/4" rib to the 3/16" square fuselage stringers on each side to provide a fillet effect. If you are not experienced at handling silk in this type of application or are using some other covering material, it is recommended that another piece of 1/4" square be added to the structure as shown in the accompanying detail so that the fin may be covered independently of the fuselage.

C. The fin is incorporated into the structure of the fuselage during its assembly, so take this into account during construction. Note particularly that the fin post extends down to the bottom of the fuselage and is notched into the rear of the fuselage frame.

D. The fin leading edge extends into the fuselage. The fin must be mounted on the fuselage before the top stringers and the 1/4" stabilizer mounting dowels and associated blocks are installed.

6. FUSELAGE

A. Protect the plans with wax paper. Pin down 1/4" square pieces to form a fuselage side frame, gluing with Sig Bond. Each side is composed of two separate sections, with the split occurring at the double 1/4" square located at Former 2. This is to permit incorporation of the taper toward the nose when the sides are joined together. Note that the right side of the fuselage is different from the left side. If you wish to install an operating cabin door. If you do not intend to use this feature, both sides may be made like the left side, without the door opening, and may be assembled on top of each other.

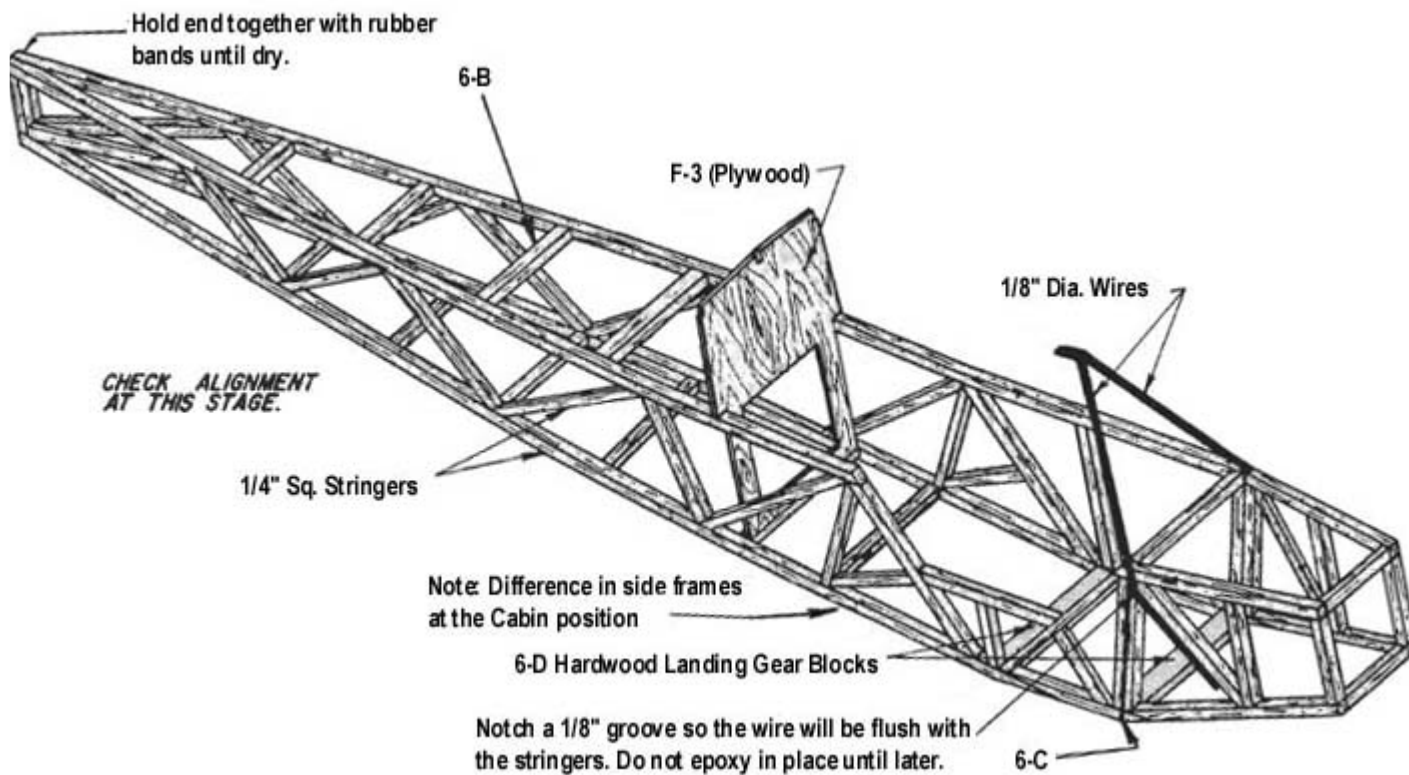

- B. Set the fuselage side frames over the top view on the plans and join, using 1/4" square cross pieces and the plywood former F-3.
- C. At the split line of the front section of the side frames, sand a bevel in the back edge so that it fits up against the other section snugly when the taper toward the nose is incorporated. Join the front sections with 1/4" square balsa.
- D. Epoxy the hardwood landing gear blocks between the fuselage side frames.

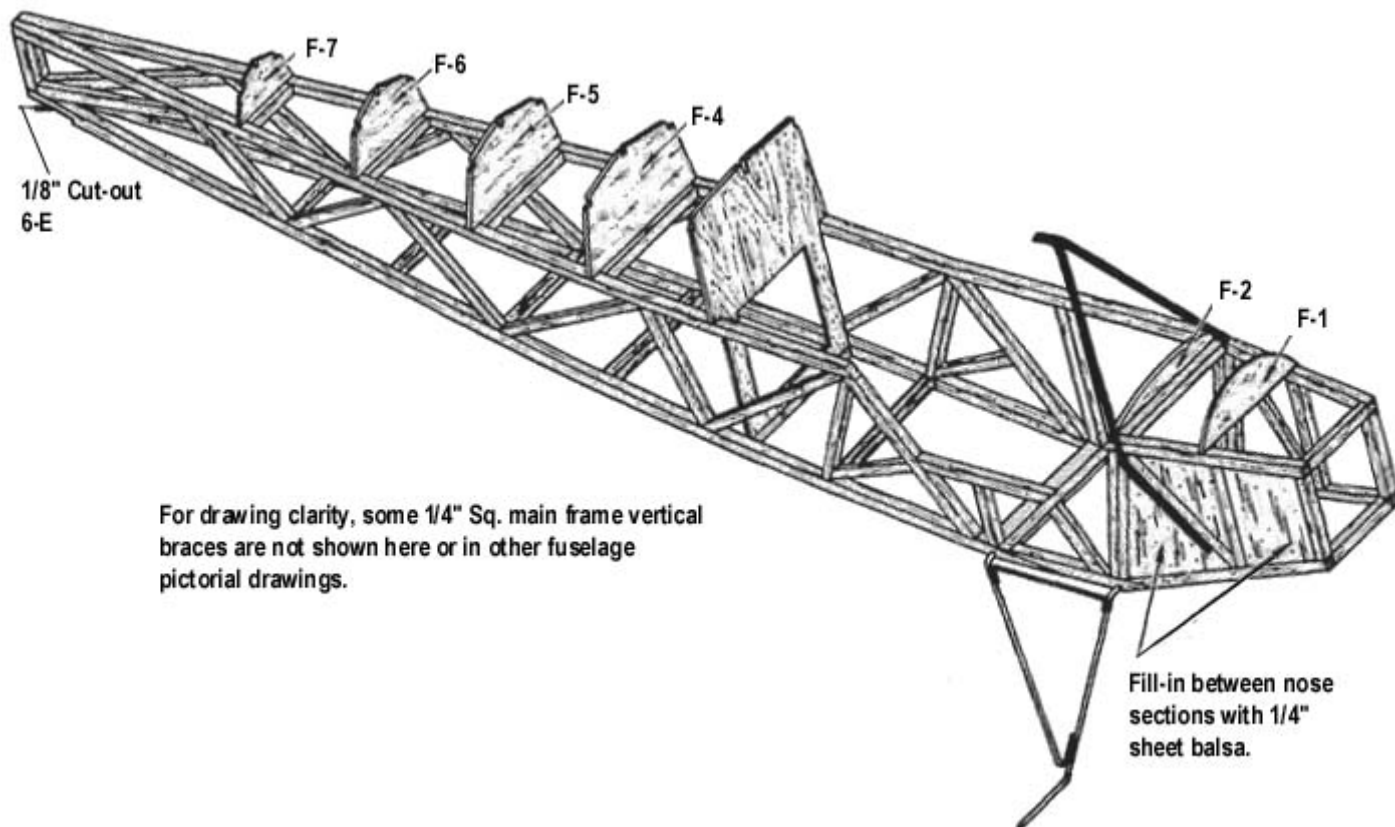

- E. Cut out 1/8" of the 1/4" sq. bottom longerons and glue on the 1/8" plywood tail wheel bracket mount. Bend the tail wheel wire, insert through the nylon tail wheel bracket. Bend the steering arm in the top. Screw the bracket to the plywood mount. Hook the steering arm to the rudder by epoxying a metal strap into the rudder. Do not fit the strap tightly against the arm but allow some clearance for free movement.
- F. Plank the fuselage sides, up to the split line at the front of the landing gear block where the nose taper begins, with 3/32" balsa sheet. Don't plank the front fuselage until after the wing hold-down wires are installed.
- G. Build two 1/8" spruce cabin frames on the plan in the same manner as the balsa fuselage sides were constructed. Note that the top of the cabin is made from lamination of 1/8" square spruce. Epoxy glue is suggested for the assembly of the spruce cabin frame. Tack a temporary cross-piece between the two sides at the front to facilitate assembly of the frames on the fuselage. If you do not wish to install an operating cabin door on the right side, the spruce pieces that represent the door may be cemented together rather than made as separate pieces.
- H. Add the hardwood triangular blocks in the corners of the top rear of the cabin.
- I. Place the completed wing in the proper position on the top of the cabin and tape in position.
- J. Protect the front of the wing with wax paper and epoxy the 1/8" plywood cross-plate to the spruce of the cabin top, resting flush against the wing center section.
- K. Notch a 1/8" groove in the fuselage frame for the 1/8" diameter wing hold down wires.
- L. Drill two side-by-side holes in the center of the cabin plywood cross-plate on through the plywood wing joiners. Cut out the wood between the two holes so that it becomes a single oblong hole.
- M. Plug the two 1/8" diameter wing hold down wires into this hole. The 1/8" wing hold down wires may have to be rebent slightly to fit perfectly into the notches in the side of the main frame and plug straight into the hole in the plywood cross-plate and into the wing. When satisfied with the fit, epoxy them to the fuselage frame, remove wing and solder the two wires together where they join at the top. Wrapping some fine copper wire around them in front of the plywood cross-plate will help make a good joint.

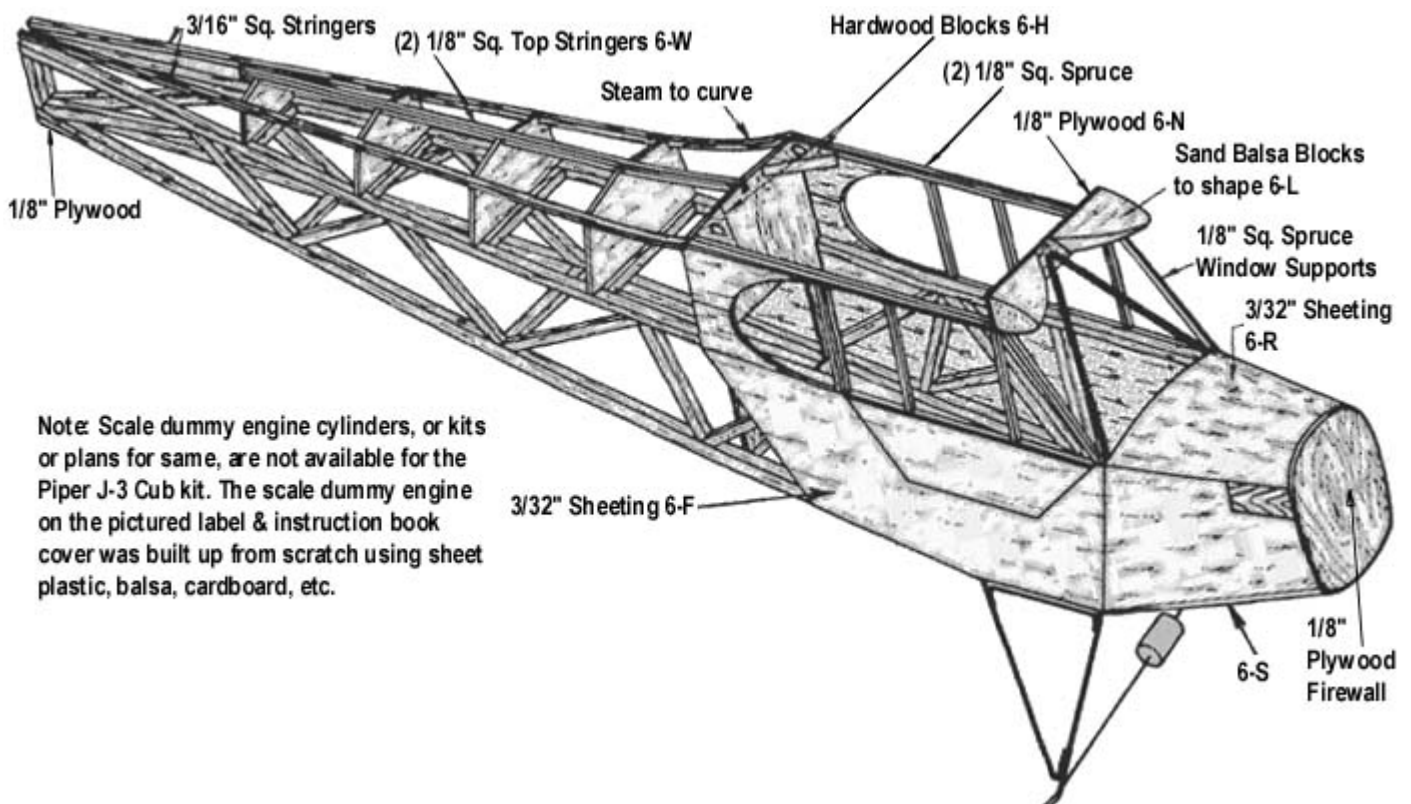
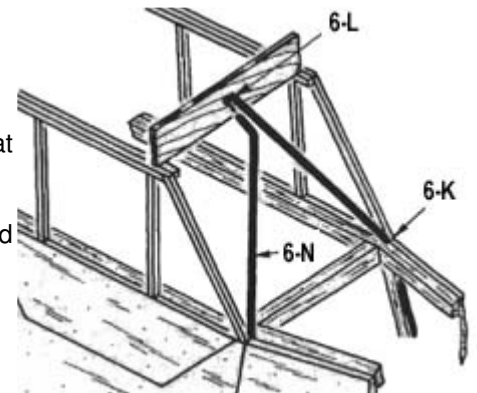

- N. Add the balsa blocks on each side of the plywood cross-plate and sand to match the shape of the wing.
- O. By pushing a pin through the wing, locate the exact spot for the wing hold down bolts in the centers of the hardwood triangles at the back corners of the cabin. Drill through the wing and on through the hardwood blocks with a number 7 drill. Remove the wing. Drill out the hole in the wing to 1/4" diameter to pass the 1/4-20 nylon wing hold-down screws.
- P. Prepare the firewall for installation by installing the blind nuts that retain the motor mounts and epoxying in place. Select and position the fuel tank while easy access is available to the inside of the fuselage nose.
(NOTE: The tank level depends on the motor installation. The center line of the tank should be about 3/8" below the needle valve. An inverted engine will therefore require a lower tank than when the engine is side mounted. The plan shows use of an inverted engine with low tank position to provide full space on both sides of the cowl for installation of a super-detailed dummy engine. For sport flying or stand-off scale events, a side mounted engine is more practical however, since the idle adjustment is less critical and the engine is easier to work on and start. Since the engine cylinders on the actual airplane are exposed, the model engine in the side-mounted position doesn't look unrealistic. The tank location for a side mounted engine requires that the top fuselage cross pieces in the nose be removed and a cut out made into the front fuselage formers F-1 and F-2 to get the tank in a high enough position. Plank the top of the fuselage nose with 3/32" balsa sheeting before removing the cross pieces and cutting into the formers to accomodate the tank. A super-detailed model with an instrument panel will need a specially selected tank shape because most standard plastic bottle clunk tanks are too long to fit in front of it.)
- Q. Drill holes through the firewall to pass the tank tubes.
- R. Plank the sides of the front fuselage forward of the split line with 3/32" sheet balsa. If the top of the front fuselage has not already been planked as described previously during installation of a side-mounted engine tank, it may be covered now. Wetting the balsa sheet will enable it to be bent around the curvature of the fuselage top.
- S. Add the balsa block bottom to the nose section.
- T. Inset 3/32" sheet balsa cabin floor between the bottom 1/4" square longerons.
- U. Epoxy the 1/8" plywood firewall to the front of the fuselage.
- V. Glue on F-1, F-2 and F-4 through F-7.
- W. Install the fin-elevator mounting blocks. Epoxy 1/4" dowels into holes. Measure from plans for accuracy.
- X. Glue the side and top stringers in place. The top stringers may have to be soaked in water or steamed near the cabin so that they may be curved into place. Note that the center top stringer is actually two 1/8" square pieces, the first glued into the notches in the formers and the second glued on top.

7. LANDING GEAR

The landing gear is most easily assembled by first fastening the front and rear 1/8" and 3/32" formed wires into the grooved landing gear blocks with the nylon strap and screws provided. Bind the 1/16" formed wires in place with fine copper wire (not furnished) such as Sig Copper Wire SH330. Some slight rebending of individual wires may be necessary to get an exact fit. When the gear is lined up properly, solder all of the copper wired connections together.

Three-inch balloon type wheels are recommended for best scale appearance. To use Banner Streamlite wheels which have a scale-like hub, solder a piece of 1/8" I.D., 5/32" O.D brass tubing over the axle. Use this type of bushing for any type of wheel which has a predrilled 5/32" hole.

8. COWLING

Notes before starting: The cowling should be assembled and fitted to the fuselage before the fuselage is covered and painted. Careful shaping of the nose is necessary to achieve a good fit. Butyrate dope thinner, MEK, or cyanoacrylate adhesives can be used to assemble the cowl. The most common cause of plastic cowls cracking is distortion of the plastic from improper installation of the plywood mounting inserts and retaining screws. If the plastic is fully supported by the plywood underneath, no strain will occur when the screws are tightened down. Keep this in mind while working through this section of the instructions.

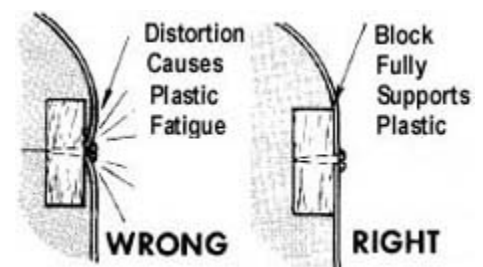

- A. Recess a piece of 3/32" plywood into the 3/32" fuselage nose sheeting in the area shown on the plan under the cowl sides. Do this on both sides of the nose.
- B. Tru-up the mating edges of the cowl halves by lightly moving across a sheet of 80 grit garnet paper laying on a flat surface.
- C. Tape the cowl halves together and try a preliminary fit of the match to the fuselage. If the cowl fits the fuselage too loosely, remove a little more width by sanding down the seam between the two halves again. Sand lightly. Carefully shape the nose as necessary to get a good, fully supporting fit under the cowl as mentioned earlier.
- D. Untape the cowl when the fit is satisfactory. Hold the plastic joiner strip in place on the inside of one cowl half. Leave half of the joiner strip extending over the edge so as to lap onto the other part when it is attached. Using a small, pointed brush, flow a few drops of thinner under the edge of the strip. It will spread along the seam by capillary action. Don't let the thinner get under your finger, it will leave a finger print.
- E. Hold the cowl halves tightly together. Use strips of masking tape to hold the opposite side (top or bottom) from which you will be gluing first. Flow thinner into the seam from the inside. Squeeze and hold together any parts of the seam not closed. Allow to dry. Remove the masking tape and join the halves on the other side. Allow to dry thoroughly.
- F. Scrape and sand the seam to take out any rough spots or flaws. Do not use course sandpaper that will cut deep scratches into the plastic. The deep scratches may later open up wider when dope is applied. Use medium paper and finish carefully with fine paper, sanding down enough to have a smooth, scratch-free surface. Low spots in the seam can be filled with Sig Epoxolite putty. Don't put on too much Epoxolite and expect to sand away the excess later. Epoxolite dries very hard and must be worked into the final desired shape before it hardens. Epoxolite can easily be shaped with your finger and/or a single edge razor blade. Dip them in water occasionally to keep the Epoxolite from sticking to them.
- G. Even up the back edges of the cowl with a sanding block.
- H. Carefully cut out the opening for the motor. The cowling for the side-mounted engine must be split through the back edge on the engine side to permit it to be fitted over the engine. Or the engine can be removed from the mounts and the split won't be necessary.
- I. With the engine mounted, tape and hold the cowl in place and in alignment with the thrust washer and fuselage. Drill a pilot hole through the cowl and into the plywood insert in the fuselage. Remove the cowl and open up the holes in it so they are large enough to pass the mounting screws.
- J. The cowling may be painted with Sig Supercoat Dope. Fine sand before doping. Don't apply heavy coats. Allow one coat to thoroughly dry before applying the next. If other lacquers or enamels are used, check compatibility with the plastic on scraps before painting.

9. DOPING AND DECORATION

The model should be covered with silk, rather than Silkspan, due to the large unplanked areas. After final sanding of the finished framework give it two coats of dope wherever you want the silk to adhere to the framework. Give these surfaces another final, light sanding. Remember that covering and paint won't cover up poor workmanship. Be sure all surfaces are smooth. Apply the silk wet but do not stretch too tightly, as it will only encourage warping later on. Pull the silk up just enough to get out all the slack and wrinkles. Paint dope around the edges. This will soak through and adhere to the pre doped framework. Let dry before trimming with a sharp double-edged (for thinness) razor blade. Check for any spots that are not stuck down and apply more dope.

Next give the entire airplane three coats of Supercoat Clear Dope. We recommend spraying if you have a spray gun. If you spray, reduce the dope at least fifty-fifty with Supercoat Thinner. If you brush, reduce the clear until it brushes easily and flows out nicely. The clear dope should fill the pores of the silk well. Next apply a fairly heavy coat of Sig Sanding Sealer. When dry, sand with No. 220 3M Tri-M-It paper. Be very careful over the ribs and the edges of the fuselage that you do not cut through the silk. Use care around stringers and any other projections, as these areas will sand through much faster than any open area.

Repeat the Sanding Sealer until you have a very smooth surface. It may be necessary to use a third coat. Low spots and rough areas can readily be seen by holding the model up to the light. If you have done a good job in preparing the surface, one or two coats of color will be sufficient. After the main color coat has been applied, mask off the pattern for the trim. After the masking tape has been applied, brush a thinned coat of clear dope along the edge of the masking tape. This will prevent the trim color from creeping under the edge of the tape. After the trim color has dried, spray a very light mist coat to clear over the entire airplane. When this has dried it can be followed by two or three fairly heavy coats of clear.

The mist coat of clear forms a barrier between the wet, heavy coat of clear and the trim colors, so that the heavy coat of clear will not soften the trim colors and cause them to bleed and run.

"DKM" STIK-TITE PRESSURE SENSITIVE DECALS

Cut out the decals with a pair of sharp scissors. Leave about 1/32" to 1/16" of clear edge around the decal. Round the corners as you are cutting. Wet the surface on which the decal will be placed with soapy water (use dishwasher detergent). Place the decal on the model and squeegee the water from underneath with a balsa paddle. Allow to dry. This procedure will prevent air from being trapped underneath as is possible when the decals are applied dry.

10. RADIO EQUIPMENT INSTALLATION

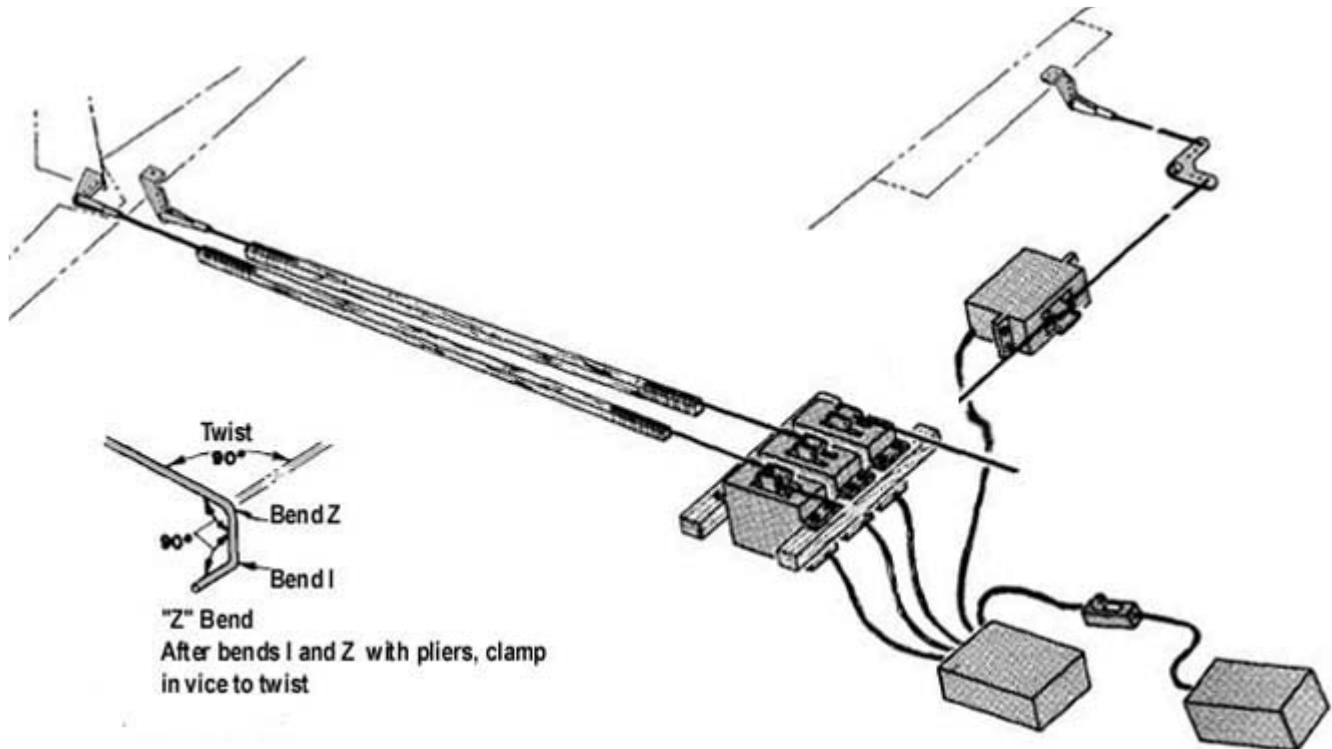

The most convenient method of installing servos is on the plastic mounts which most of the radio equipment makers offer with their outfits or as an accessory. These are screwed to hardwood mounting rails for fuselage servos or to plywood plates for mounting in the wing. Instructions for the use of these mounts are included with them.

Servos for which plastic mounts are not available can be screwed directly to at least 3/8" square hardwood rails placed across the cabin, three abreast, as shown in the drawing. With rubber grommets installed in the servo mounting holes, mark the spots for drilling pilot holes for screws. Space the servos at least 1/8" apart and do not have them contacting the hardwood mounting rails except on the grommets. Using a washer on the wood screws, mount the servos to the rails. Do not tighten the screws down against the grommets since this will cause vibration to be transferred to the servos. The washer should just rest against the grommet without compressing it.

The aileron servo should be mounted in an opening cut in the bottom of the center section planking between the main spar and the rear spar on a 1/8" plywood plate glued to the top center section planking. The servo will protrude into the cabin since the wing is not deep enough to fully accommodate it within. If a plastic aileron servo mount is not available, the servo can be screwed to hardwood scabs glued to the top center section planking. The pushrod from the aileron bellcrank in the wing is 1/16" wire. Certain servos may require re-positioning of the plywood bellcrank mounting platform in the wing to obtain a straight run to the servo output arm so it is advisable to set up your servo installation and check it out before covering the wing. Do not make large holes in the wing ribs to pass the aileron servo pushrods. Sharpen a 1/16" wire and punch holes through the ribs in the places required by your servo installation.

The drawing shows a convenient way to make a "Z" bend in the end of a wire for easy connection of a pushrod or R/C link to a nylon bellcrank. The pushrod may be threaded through the ribs before the bellcrank is bolted in place. Soldered connections to the bellcrank are not recommended because the nylon can be damaged by the heat of the iron. The pushrods for the fuselage are pieces of firm 1/4" square balsa. The 1/16" wire ends are wrapped with thread and coated with glue. A variety of quickly detachable pushrod retainers are available from the Sig Catalog for hooking the pushrods to the servos. Avoid metal to metal contact in linkages because this may produce harmful radio interference. Fuselage pushrods may also be of the nylon tubing type if desired. Pushrods should be installed before covering the fuselage. Openings around the exit point for the pushrod may be framed with scrap balsa pieces to provide a place to fasten the covering material. Plastic tubing pushrods may require supporting crosspieces at one or two places in the fuselage to hold them in the best operating position and keep them from flexing excessively during operation.

The switch may be mounted wherever convenient on the side of the model, preferably the side away from the engine oil. For the best scale appearance it could be mounted internally on a small scrap block with an operating wire protruding through a small hole in the side or bottom.

The receiver battery pack should be wrapped in foam rubber sheet, held on with rubber bands and placed as far forward as possible, under the tank. It is a good idea to put the package in a small plastic bag, taped shut around the battery cable to protect the battery from accidental fuel leakage.

The receiver should be similarly wrapped up in foam rubber to protect it from engine vibration. Cover it with a plastic bag also. Stow this package under the servos or ahead of them if there is room available. Make certain that the receiver will stay in place during acrobatic maneuvers.

11. PRE-FLIGHT

Set the model up on a table in a level attitude. With a straight edge held along the bottom of the stabilizer, use ruler measurements to insure that the wing incidence is the proper amount. The bottom of the wing at the cabin brace wire plywood piece should be 1/8" higher than the bottom of the wing trailing edge. If the wing incidence is not correct, adjust by adding shims under the leading or trailing edge as required. These corrections should be done before the model is covered.

The following control surface movements are recommended for test flying. All measurements are taken at the trailing edge of the control surface. After test flying, you may want to increase or decrease the surface movements to suit your own preferences.

RECOMMENDED CONTROL SURFACE MOVEMENTS

Elevator	1/2" up and 1/2" down
Ailerons	3/8" up and 3/8" down
Rudder	1" each way

Be certain to carefully range check your radio equipment and see how it operates with the engine running before attempting test flights. A lot of problems can be avoided if the engine has been well broken-in and idle adjustment perfected on a test block or in another airplane before installation in the model.

A properly balanced and aligned model with a reliable engine and radio is assured of successful test flights.

12. BALANCING

The Center of Gravity position shown on the plan is the rearward limit. Do not balance any farther back than this point even if lead must be added to the nose. Trying to fly with the C.G. too far back is much more dangerous than the slight increase in wing loading caused by adding nose weight. Balance with an empty fuel tank. For test flights it is recommended that the C.G. be positioned 1/2" to 3/4" ahead of the plan location. When slightly nose heavy the model is much more stable and less likely to stall or snap roll. The reaction to control movements is also less sensitive with a forward C.G. so it is not easy to overcontrol. Some aerobatic ability may be sacrificed with a forward C.G. so you may wish, after test and familiarization flights, to move it rearward. Do this gradually and check results and control response in the air at a good altitude.

13. FLYING

If you are a newcomer to model flying it is suggested that you not attempt flying without the assistance of a modeler with experience. Contact your local model club or ask your hobby dealer for the names of good fliers in your vicinity and a suitable location for flying. Many hours of work are involved in the construction of a model and it can all be lost in a moment of beginner's indecision. A skilled flyer can help you to get past the first critical test and trimming flights without damage to the model and give instruction in proper control.

If a good, smooth take-off surface is not available, the model may be hand-launched. Holding the model just behind the landing gear with the left hand and under the tail with the right, run into the wind at a fast trot and thrust the model forward with the nose slightly down in a spear-throwing motion. It is not necessary to achieve a lot of velocity in the launch- it is more important that it be released smoothly and with wings level. The model may dip slightly and then should begin climbing at a slight angle. If it does not begin to climb after about fifty feet of flight, apply a small amount of up elevator to lift the nose.

Use rudder or aileron to keep the wings level and headed straight into the wind until about 75 feet of altitude is obtained. Keep first turns gentle and not steeply banked. Stay up wind of the transmitter. Use trim levers on your radio equipment where necessary to obtain straight and level flight with the control sticks in neutral position but don't attempt to make these adjustments until the model is at a good altitude. Throttle back at altitude to find out the model characteristics in a gliding condition so that some indication is seen of what to expect during the landing approach. It is a good idea to make several practice landing approaches at a good altitude to get the feel of the model for this approaching critical maneuver. Make your final and complete landing approach while your engine still has plenty of fuel remaining so that the engine is not liable to stop before completion of the flight. This will allow application of power if the approach is being undershot. Notice the percentage of missed landings at an R/C flying field. Those undershot greatly outnumber those missed by overshooting. So if an approach that looks a little high is maintained, chances are good that a spot-on landing can be made.

WARNING - DANGER! -Important: Read These Warnings:

- Do Not fly control line or towline models within 300 feet of electric power lines. Instant death from electrocution can result from coming near them. Direct contact is not necessary.
- A model airplane motor gets very hot and can cause serious burns. Do not touch the motor during or after operation.
- Keep clear of the propeller. It can cut off a finger or put out an eye. Make sure the propeller is securely fastened in place and is not cracked.
- Model airplane fuel is flammable and poisonous. Take the same precautions while transporting and using it that you would with a can of gasoline or a bottle of poison.
- Remember that it is possible to lose control of a model airplane. Do not fly in locations where the model may hit people or damage property if loss of control occurs.
- Check your model and equipment regularly to insure it is in safe operating condition.

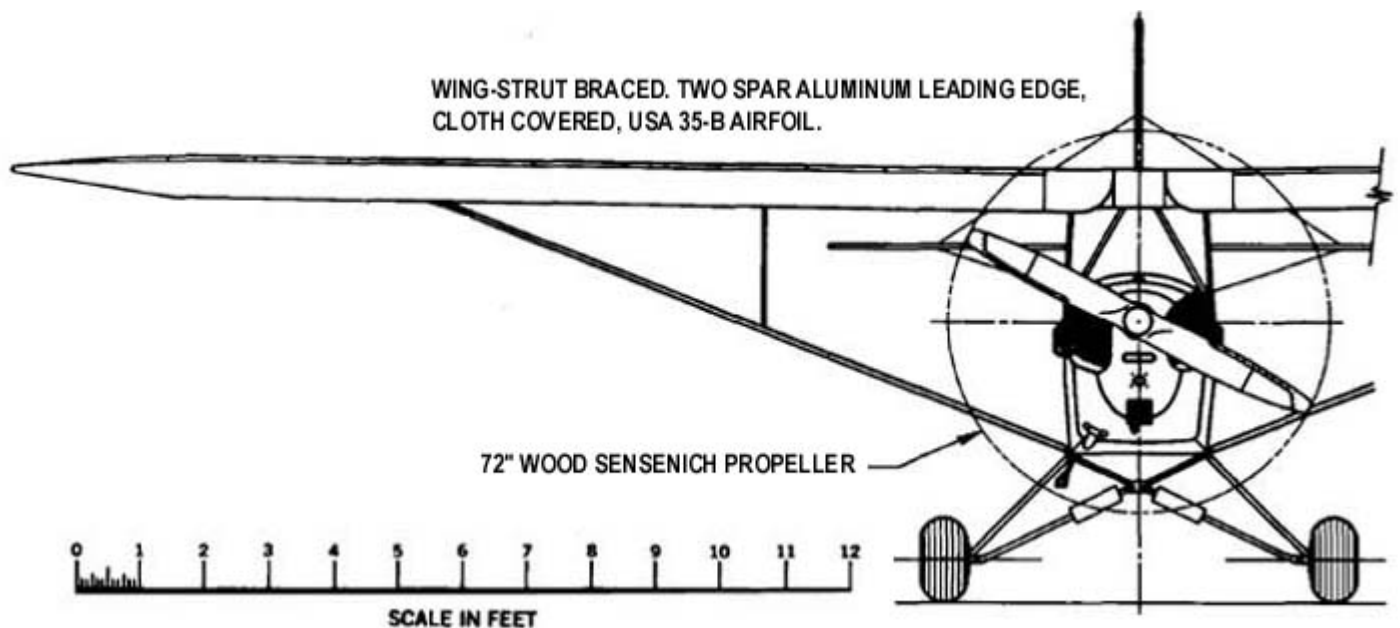



PIPER J-3 CUB

WINGSPAN: 35' 2 1/2"	TOP SPEED: 87 M.P.H.
LENGTH: 22' 7 1/2"	CRUISING SPEED: 75 M.P.H.
HEIGHT: 6' 8"	LANDING SPEED: 38 M.P.H.
WING CHORD: 5' 3"	EMPTY WEIGHT: 680 LBS.
CONTINENTAL A65-8 (65 H.P.)	GROSS WEIGHT: 1220 LBS.

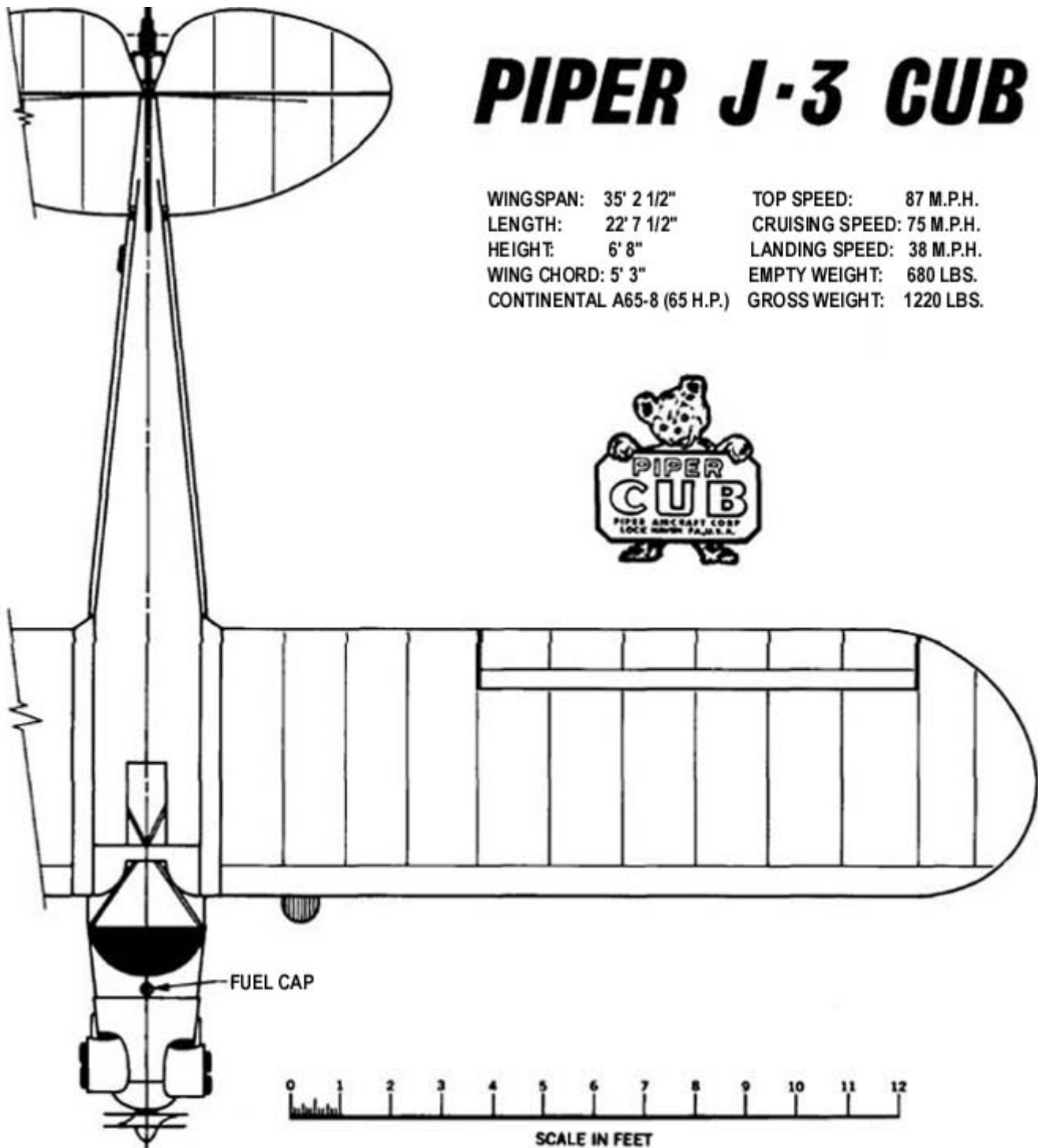

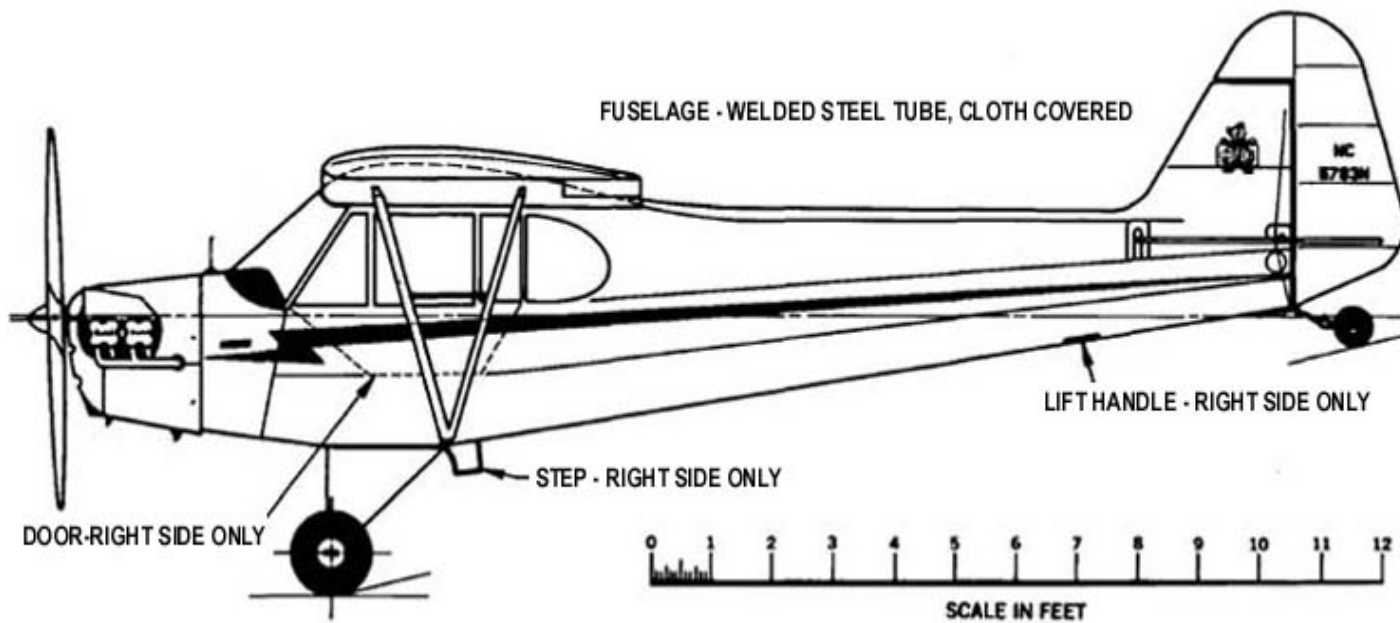

© Copyright SIG Mfg. Co., Inc.

SIG MFG. CO., INC.....Montezuma, Iowa 50171-0520

LIMIT OF LIABILITY:

In use of our products, Sig Mfg. Co.'s only obligation shall be to replace such quantity of the product proven to be defective. User shall determine the suitability of the product for his or her intended use and shall assume all risk and liability in connection therewith.