

FMS

1:18

CHEVROLET APACHE 6X6

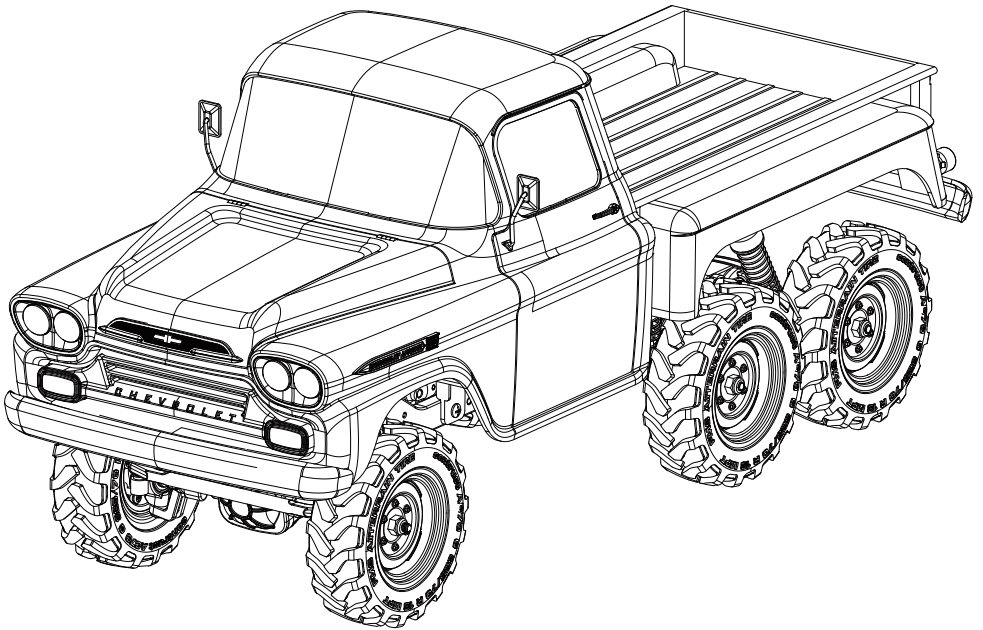

Instruction Manual
操作手册

This product is not a toy! (14+) Recommended for ages 14 and up. Adult supervision required for ages under 14 years old. Contains small parts, keep out of reach of children 3 years of age and younger.



MADE IN CHINA

Certification

FCC Compliance Statement

This device complies with Part 15 of the FCC Rules. Operation is subject to the following two conditions: (1) this device may not cause harmful interference, and (2) this device must accept any interference received, including interference that may cause undesired operation.

Warning: changes or modifications not expressly approved by the party responsible for compliance could void the user's authority to operate the equipment.

This equipment has been tested and found to comply with the limits for a Class B digital device, pursuant to Part 15 of the FCC Rules. These limits are designed to provide reasonable protection against harmful interference in a residential installation. This equipment generates, uses and can radiate radio frequency energy and, if not installed and used in accordance with the instructions, may cause harmful interference to radio communications. However, there is no guarantee that interference will not occur in a particular installation.

If this equipment does cause harmful interference to radio or television reception, which can be determined by turning the equipment off and on, the user is encouraged to try to correct the interference by one or more of the following measures:

- 1.Reorient or relocate the receiving antenna.
- 2.Increase the separation between the equipment and receiver.
- 3.Connect the equipment into an outlet on a circuit different from that to which the receiver is connected.
- 4.Consult the dealer or an experienced radio/TV technician for help.

RF Exposure Compliance

This equipment complies with FCC radiation exposure limits set forth for an uncontrolled environment. This equipment should be installed and operated with minimum distance 20cm between the radiator and your body. This transmitter must not be co-located or operating in conjunction with any other antenna or transmitter.

Environmentally friendly disposal

Old electrical appliances must not be disposed of together with the residual waste, but have to be disposed of separately. The disposal at the communal collecting point via private persons is for free. The owner of old appliances is responsible to bring the appliances to these collecting points or to similar collection points. With this little personal effort, you contribute to recycle valuable raw materials and the treatment of toxic substances.





FCC ID: N4ZR4A10

RADIO SYSTEM

Safety symbols

Pay close attention to the following symbols and their meanings. Failure to follow these warnings could cause damage, injury or death.

 Attention	Not following these instructions may lead to minor injuries.
 Warning	Not following these instructions may lead to major injuries.
 Danger	Not following these instructions may lead to serious injuries or death.

Safety guide



Prohibited



Mandatory

- Do not use the product at night or in bad weather like rain or thunderstorm. It can cause erratic operation or loss of control.

- Do not use the product when visibility is limited.

- Do not use the product on rain or snow days. Any exposure to moisture (water or snow) may cause erratic operation or loss of control.

- Interference may cause loss of control. To ensure the safety of you and others, do not operate in the following places:

- 1、 Near any site where other radio control activity may occur
- 2、 Near power lines or communication broadcasting antennas
- 3、 Near people or roads
- 4、 On any body of water when passenger boats are present

- Do not use this product when you are tired, uncomfortable, or under the influence of alcohol or drugs. Doing so may cause serious injury to yourself or others.

- The 2.4GHz radio band is limited to line of sight. Always keep your model in sight as a large object can block the RF signal and lead to loss of control.

- Do not touch any part of the model that may generate heat during operation, or immediately after use. The engine, motor or speed control, may be very hot and can cause serious burns.

- Misuse of this product may lead to serious injury or death. To ensure the safety of you and your equipment, read this manual and follow the instructions.

- Make sure the product is properly installed in your model. Failure to do so may result in serious injury.

- Make sure to disconnect the receiver battery before turning off the transmitter. Failure to do so may lead to unintended operation and cause an accident.

- Ensure that all motors operate in the correct direction. If not, adjust the direction first.

- Make sure the model stays within the systems maximum range to prevent loss of control.

PRODUCT INTRODUCTION

About Model

In the 1950s and 1960s, the influence of World War II disappeared, and the United States entered a "golden age". People began to dream a life of ease—or luxury. In this prosperous era, even building a truck requires attention to every inch of detail, if not too extravagant. Chevrolet Apache is one of the representative works under this trend of thought.

The history of Chevrolet trucks dates back to 1918, and there are many models that have become cultural icons in a century of truck manufacturing. FMS is honored to be authorized and guided by Chevrolet to transform the cultural symbol of Apache into a 1:18 remote control model car.

In terms of restoration, the FMS 1:18 remote control model faithfully shows the structure and rich details of the original Apache car. Injection-molded hard body, sunken frame, accurate proportion of stamp-formed car hopper (convenient to carry all kinds of 1:18 simulation parts, such as motorcycles, kayaks and various camping equipment), spacious cab (scaled center console, steering wheel, bench seat) are just the starting line. Wraparound design windshield and large rear window, classic metal plated grille/ mirrors/ wheel hubs, the linkage light control (headlights, turn signals, reversing lights) and other subtleties are the most sincere compliments from FMS to the original Apache.

In terms of performance, FMS adheres to the fundamental principle of simplicity, and designs Apache with the standard of "not fussy, just go play". Using metal chassis, four-link suspension, 6x6 all-wheel drive, universal joint transmission...simple, strong and reliable. In addition, the rubber material all-terrain wear-resistant soft tires take into account both road and off-road performance.

FMS 1:18 Chevrolet Apache, a six-wheel-drive remote control car that can be locked in a glass case to reminisce the old days or taken out for a wild ride.

Features

- READY TO RUN MODEL
- 6WD ALL-WHEEL DRIVE
- RIGID METAL GIRDER
- METAL GEARS STEERING SERVO
- FOUR LINK SUSPENSION
- HIGH STRENGTH INTEGRATED NYLON FRAME
- PAINTED INJECTION-MOLDED HARD BODY
- FUNCTIONAL HOOD
- REMOTE CONTROL LIGHTING SYSTEM
- ORIGINAL PERSONALIZED STICKERS
- PLATED SCALED DETAILS
- 050 HIGH TORSION BRUSH MOTOR
- 2.4GHZ RADIO

Transmitter instruction

Intruccion

FS-R4A1 based on ANT protocol is a three-in-one receiver with ESC and LED light group control board. It has an external single antenna, can output PWM signal and light control signal, can implement two-way transmission, adopts automatic binding, and has a compact design, which can be adapted to various model cars.

TransmitterOverview

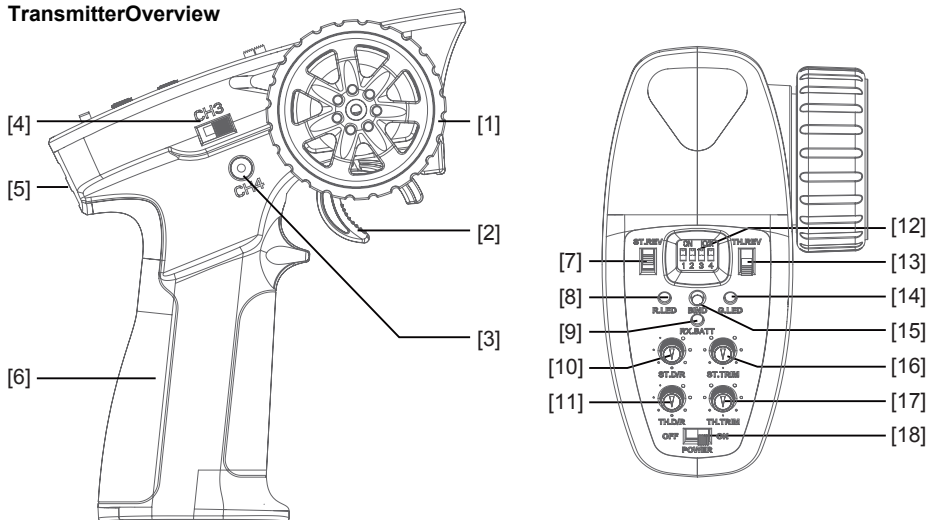

[1]	Traversing handwheel, 35 degrees on each side (CH1)	[10]	ST.D/R
[2]	Throttle button, 25 degrees in front and 12.5 degrees at rear (CH2)	[11]	TH.D/R
[3]	Click (CH4) [Click for the lighting effect function, long press for other functions, such as two/four-wheel drive switching]	[12]	Switch to the electric adjustment mode
[4]	Three-position toggle switch (CH3)	[13]	TH.REV
[5]	Lanyard hole	[14]	G.LED
[6]	Handle, 4*AAA battery compartment	[15]	BIND
[7]	ST.REV	[16]	ST.TRIM
[8]	R.LED	[17]	TH.TRIM
[9]	RX.BATT	[18]	Power Switch

*[3]Click (CH4)Note: Not all models have this feature.

Overview

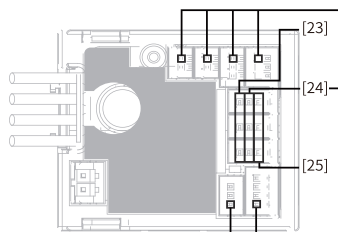
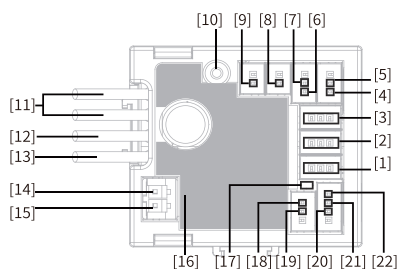

- | | |
|---------------------------|----------------------------|
| [1] CH1 | [14] Motor port "+" |
| [2] CH3 | [15] Motor port "-" |
| [3] CH4 | [16] Stickers |
| [4] Left-turn light port | [17] LED |
| [5] Head light port | [18] Left-turn light port |
| [6] Right-turn light port | [19] Right-turn light port |
| [7] Head light port | [20] Reversing light port |
| [8] Fog light port | [21] Brake light port |
| [9] Fog light port | [22] Taillight port |
| [10] Antenna | [23] Signal pin |
| [11] Power switch | [24] Power "+" |
| [12] Battery line "+" | [25] Power "-" |
| [13] Battery line "-" | |

Specifications

- Product Name: FS-R4A1
- Adaptive transmitter: FS-MG41
- Model Type: Car
- Channels: 4
- Numbers of Light Interfaces: 7
- RF: 2.4GHz ISM
- 2.4G Protocol: ANT
- Antenna: Single antenna
- Input Power: Lipo (2S)/NiMH (5~7Cell)
- BEC Output: 6V/1A
- Continuous/Peak Current: 10A/50A
- Data Output: PWM
- Temperature Range: -10℃ —+60℃
- Humidity Limit: 20%~95%
- Waterproof: PPX4
- Online Update: No
- Dimensions: 33mm*30mm*12mm
- Weight: About 11g
- Certification: CE, FCC ID: N4ZR4A10

Binding

The receiver automatically enters the binding state once it is powered on.

Press the **BIND** Key to turn on the transmitter and allow it to enter its binding state. Here, **G.LED** flashes quickly, and operator releases the **BIND** Key.

1. When the receiver is powered on and waits for 1 second, it will automatically enter the binding state if it is not connected;
2. After the binding is successful, the LED indicator of the receiver is always on.

Notes: (1) Set the transmitter to its binding state first, and then set the receiver to its binding state. If the binding is not completed within 10s, the indicator light of the receiver will enter its slow flashing state. (2) If re-binding is successful, all the settings of the car lights will be restored to their default values.

ESC protection

This receiver has multiple prompt functions such as power-on self-check display, overheating alarm prompt, and low/high voltage alarm prompt.

- Self-check display: all car lights will be on for 1S when the receiver is powered on;
- Overheating alarm: When the internal temperature of the ESC is detected to exceed 110 °C, motor has no output, all car lights flash promptly, and the normal output will be restored when the temperature is lower than 70°C;
- Low/high voltage alarm: When the receiver enters the low voltage protection, motor has no output, and all the lights flash slowly; when the receiver enters the high voltage protection, all channels have no output. All car lights flash promptly.

ESC function instructions

1. Connect related equipment:

Make sure the ESC is off before connection. Connect the motor with M+ and M- of ESC. Connect the steering servo to the 3Pin interface marked with "ST" of ESC (- + S connected correspondingly). Connect the battery with the positive and negative poles of ESC correspondingly.

2. Normal boot, identification throttle midpoint:

After connecting related equipment as step 1, turn on the radio first, move the throttle trigger to the neutral position. Turn on the switch of ESC at last. The receiver will automatically recognize the battery type when it is powered on again. Then it can run it.

Notes:

- a. The ESC can be run after completing self-inspection (about 3 seconds) if power on, otherwise it cannot be operated normally.
- b. If there is no power output and the red light of ESC flashes quickly after power on, please check whether the throttle trim of the transmitter is set to the "0" position, the receiver will automatically recognize the midpoint of the trim throttle after restarting;
- c. If the rotation direction is not correct during running, exchange the two wires connecting motor and ESC.
- d. To make sure everything is ok, please turn on the transmitter first and finally turn on the ESC, turn off the ESC first and finally turn off the transmitter.

Notes: Please refer to the relevant sections for details about the battery type, drag brake force and running mode of the ESC.









Failsafe

This function is used to protect the safety of the model and the operator when the receiver cannot normally receive the signal from the transmitter and is out of control. The receiver defaults that the throttle channel is fixed to be out of control and enters the brake state. After other channels are out of control, the receiver has no signal output. If you set it on the transmitter, it will output according to the set value.

Attention:

- Make sure the product is installed and calibrated correctly, failure to do so may result in serious injury.
- Please carefully check each power device and car frame instructions to ensure the power matching is reasonable before use. Avoid damaging power system due to incorrect matching.
- Do not let the external temperature of the system exceed 90°C /194°F , because high temperature will damage the power system.
- Make sure the receiver's battery is disconnected before turning off the transmitter, failure to do so may lead to unintended operation or loss of control.
- After use, remember to disconnect the battery and the ESC. If the battery isn't disconnected, the ESC will consume electric energy all the time even if it is off. It will discharge completely if connect the battery for a long time, thus resulting in the failure of the battery or the ESC. We are not responsible for any damage caused by this!
- Make sure the receiver is mounted away from motors or any device that emits excessive electrical noise.
- Keep the antenna of the receiver at least 1cm away from conductive materials such as carbon or metal.
- Do not power on the receiver during the setup process to prevent loss of control.

ESC Parameter Setting

Running Mode	Battery Type	Drag Brake	
 FWD/REV/BRK	 Lipo	 0%	 75%
 FWD/REV	 NiMH	 50%	 100%

Dial Switch sign

The Dial Switch on the transmitter is used to set ESC parameters, that is, the Dial Switch is located at different positions and the corresponding parameter values are different.

Setting Method:

There are three parameters can be set for the ESC, which are "Running mode", "Battery type", "Drag brake", There are slide switches numbered 1 2 3 4 on the radio panel . The above parameters can be set by dialing down and up.

The specific operation is as follows:

When No. 1 slide switch is on the down, it indicates that the operation mode is set to FWD / REV / BRK.

When No. 1 slide switch is on the up, it indicates that the operation mode is set to FWD/REV.

When No. 2 slide switch is on the down, it indicates that the battery type is set to Lipo.

When No. 2 slide switch is on the up, it indicates that the battery type is set to NiMH.

When No. 3 and No.4 slide switch are on the down, it indicates that the drag brake force is set to 0%.

When No. 3 slide switch is on the down and No.4 slide switch is on the up, it indicates that the drag brake force is set to 50%.

When No. 3 slide switch is on the up and No.4 slide switch is on the down, it indicates that the drag brake force is set to 75%.

When No. 3 and No.4 slide switch are on the up, it indicates that the drag brake force is set to 100%.

Parameter Explanation:

1. Running Mode

FWD/REV/BRK: This mode adopts "double click" reverse mode, that is, when the throttle trigger is pushed from natural range to the reverse area for the first time, the motor is only braking and will not reverse; when the throttle trigger is moved back to the natural range and pushed to the reverse area for the second time, it will reverse. This mode is applicable to general models.

FWD/REV: This mode adopts "one click" reverse mode, that is, when the throttle trigger is pushed from natural range to the reverse area, the motor immediately generates reverse action, which is generally applied to rock crawler.

Parameter setting method:

When No. 1 slide switch is on the down, it indicates that the operation mode is set to FWD / REV / BRK.

When No. 1 slide switch is on the up, it indicates that the operation mode is set to FWD/REV.

2. Battery Type

There are LiPo and NiMH cells. The low-pressure protection value is different under different types. It can be set according to the actual use.

Parameter setting method:

When No. 2 slide switch is on the down, it indicates that the battery type is set to Lipo.

When No. 2 slide switch is on the up, it indicates that the battery type is set to NiMH.

3. Drag Brake Force

The drag brake means that when the throttle trigger moves from the forward or reverse area to natural range, it will produce certain braking force to the motor, the larger the value is, the greater the drag brake force is. Select proper braking force according to the actual situation.

Parameter setting method:

When No. 3 and No.4 slide switch are on the down, it indicates that the drag brake force is set to 0%.

When No. 3 slide switch is on the down and No.4 slide switch is on the up, it indicates that the drag brake force is set to 50%.

When No. 3 slide switch is on the up and No.4 slide switch is on the down, it indicates that the drag brake force is set to 75%.

When No. 3 and No.4 slide switch are on the up, it indicates that the drag brake force is set to 100%.







Lighting function

Button	Light Position	Function	Power on is off by default	Times for Pressing					Control Mod	Remarks
				I	II	III	IV	V		
CH4	Headlight	White headlights keep on		OFF	•	OFF	OFF	OFF		
		White headlights keep on with high brightness		OFF	OFF	•	•	OFF		
	Taillights	Taillights keep on		OFF	•	•	•	OFF		
	Turn signal	Left turn orange light		OFF	○	○	○	○	Direction linkage control	3 left turn signals automatically blink in the left turn with a 1-sec flashing frequency, namely on 0.5 sec and off 0.5 sec.
		Right turn orange light		OFF	○	○	○	○	Direction linkage control	3 right turn signals automatically blink in the right turn with a 1-sec flashing frequency, namely on 0.5 sec and off 0.5 sec.

Getting started

Before operation, install the battery and connect the system as instructed below.

★ Transmitter Battery Installation

 Danger	Only use specified battery (X4 AA batteries).
 Danger	Do not open, disassemble, or attempt to repair the battery.
 Danger	Do not crush/puncture the battery, or short the external contacts.
 Danger	Do not expose to excessive heat or liquids.
 Danger	Do not drop the battery or expose to strong shocks or vibrations.
 Danger	Always store the battery in a cool, dry place.
 Danger	Do not use the battery if damaged.

Battery Type: AAA

Battery Installation:

1. Open the battery compartment cover.
2. Insert 4 fully-charged AAA batteries into the compartment. Make sure that the battery makes good contact with the battery compartment's contacts.
3. Replace battery compartment cover.

Low battery alarm: When the battery is lower than 4.2V, the LED on the panel will flash slowly.

Instructions

After setting up, follow the instructions below to operate the system.

1. Automatic code matching (the transmitter and receiver have been successfully coded before leaving the factory.)

If you need to replace another transmitter or receiver, please follow the following steps to code:

1. When the transmitter power is on and the code matching mode is on, the light keeps flashing;
2. The power supply of the receiving board is turned on, and the front lights keep flashing to enter the code matching mode;
3. When the code matching is successful, all the transmitter lights are on and all the lights on the car are off;

Note: when code matching, please operate the transmitter to enter the code matching state first, and then operate the receiver to enter the code matching state.

THROTTLE STICK POSITION

Throttle stick position

Neutral point



Top point of forward direction

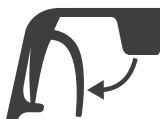

Top point of backward direction



Charging the Battery

1. Connect the charger to a USB port then connect the battery to the charger.
2. When charging, the Green LED is flash, when charged, the Green LED is stable.
3. Do not let the battery charge unattended!
4. If the battery or charger is hot, disconnect the battery and charger immediately as this may be caused by an internal short-circuit.

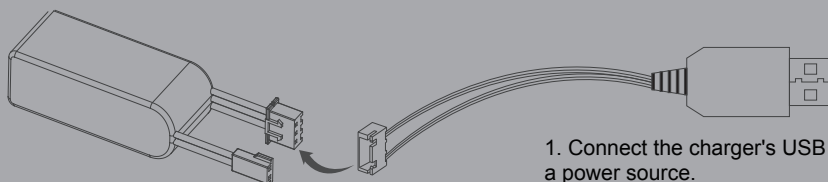

2. Connect the battery to the charger.

1. Connect the charger's USB port to a power source.

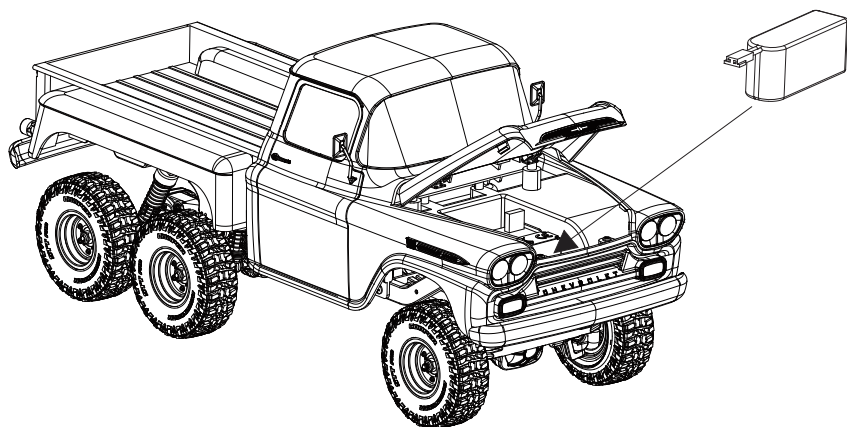

NOTE

- 1.If it is not in use for a long time, unplug and take off the battery to prevent battery leakage.
- 2.Do not open, disassemble, or attempt to repair the battery.
- 3.The battery needs to be disconnected from vehicle before it can be charged
- 4.Do not charge battery in vehicle.

Spare parts list

C2193	11820 Hood	C2206	11820 Window
C2194	11820 Front and Rear Light Cup Set	C2063	Shock Plastic Parts
C2195	11820 Hood Mount Set	C2207	11820 Connecting Rod
C2196	11820 Rearview Mirror	C2066	Ball Head
C2197	11820 Bumper set	C2067	Steering Hub & Spindle
C2198	11820 Lens set	C2208	Front/rear Axle Parts
C2199	11820 Body SHELL	C2069	Servo Horn
C2200	11820 handle set	C2209	11820 MIRROR LENS
C2045	Teraz Tire 19.2 x 13.5 x 56	C2071	Wheel Hex
C2201	Star Style Wheels plastic parts electroplate	C2073	BEARING Set
C2052	LIPO Battery 2S LIPO 380mAh	C2074	Rear Wheel Shaft
C2202	11820 Light set	C2075	Front Outdrive Shaft
C2051	FMS USB Charger	C2076	Gear Box Plastic Parts
C2049	050 Motor set	C2021	1KG High Torque 3wire Servo
C2057	Plastic Gear set	C2133	M4 Ball Head
C2203	11820 Transmission Shaft full set	C2120	MG41 + R4A Transmitter Receiver Set
C2204	11820 Screw set	C2121	R4A ESC/RX Combo
C2205	11820 Drive axle Metal Gear	C2122	MG41 Transmitter
C2060	M2&M2.5 Screw Net	C2210	11820 Dash Board

安全保障措施

指引

本手册可以有效帮助您正确操作、维护和修理本品。由于本品所涉多数部件为特有部件，请保留本手册作为未来参考之用。

这款产品由精密制造的组件组成，非玩具级别，不适合14岁以下的儿童操作使用。

未成年人应在有经验的成年人陪同下操作使用。不当操作或维护会造成车辆损坏，甚至可能导致人身及财产损失。

本品操作者需以安全的方式操作本品。及其分销商不以任何方式对不当使用本产品所造成的任何人身伤害或财产损害负责。

安全、预防措施及警告

- 请使用原厂部件更换损坏的部件。特别注意所有车辆接线的正负极。
- 务必选择合适的环境操作遥控模型，所选环境需远离电缆、无线电塔、深水及不稳定地形。本品操作者对其行为全权负责。
- 本品由精密电子部件构成。请勿将本品暴露于潮湿的环境或者其他污染物中，以免造成损坏。
- 确保每次操作前检查车辆的无线接收范围，以防止无线信号丢失或受干扰。
- 在您的能力范围内操作此产品。在任何时候，如果车辆操作有危险，则绝对不值得冒险。
- 通电方式：务必先开遥控器再将车子通电。断电方式：务必先将车子断电再关遥控器。以上顺序如逆转，则可能引起遥控模型失控，导致人身伤害或财产损失。
- 遥控器电池低电时，不要操作模型车，以免造成失控。
- 模型产品上的塑胶件容易因极冷或极热气候出现变形或损坏的状况。所以请将模型产品存放于常温环境中。

使用前请仔细阅读本手册。我们不对任何故意损坏或不当使用负责。这个产品不是玩具！建议14岁及以上者使用。14岁以下的用户，需要在成年人监督下使用。本产品部分包含小零件，请务必保证3岁及以下儿童不能接触本产品。



无线电系统

安全符号

仔细阅读以下符号及其相关说明，如不按照以下指引进行操作，可能会导致设备损坏或人员伤亡。

⚠ 注意 如果使用者不按照说明方法操作，有可能导致操作者或他人受到轻微伤害。

⚠ 注意 如果不按照说明方法操作，可能导致操作者或他人遭受较大伤害。

⚠ 注意 如果不按照说明方法操作，可能导致操作者或他人严重受伤，甚至遭受生命危险。

安全信息



禁止



强制



- 请不要在夜晚或雷雨天气使用本产品，恶劣的天气环境有可能导致遥控设备失灵。
- 请不要在能见度有限的情况下使用本产品。
- 请不要在雨雪或有水的地方使用本产品。如果有液体进入到系统内部，可能会导致运行不稳定或失灵。
- 信号干扰可能导致设备失控。为保证您和他人的安全，请不要在以下地点使用本产品：
 - 1、通信基站附近或其他无线电活跃的地方
 - 2、人多的地方或道路附近
 - 3、水域附近
 - 4、高压电线或通信广播天线附近
- 当您感到疲倦、不舒服，或在摄入酒精或服食导致麻醉或兴奋的药物后，不要操作本产品。否则可能对自己或他人造成严重的伤害。
- 2.4GHz无线电波段完全不同于之前所使用的低频无线电波段。使用时请确保模型产品在您的视线范围内，大的障碍物将会阻断无线电频率信号从而导致遥控失灵模型失控。



- 在操作或使用模型后，请勿触摸任何可能发热的部位，如电池、电机等。这些部件可能非常热，容易造成严重的烧伤。
- 遥控设备使用不恰当可能导致操作者或他人严重受伤，甚至死亡。为保证您和设备的安全，请仔细阅读使用说明书并按照规定要求进行操作。
- 使用前必须确保本产品与模型安装正确，否则可能导致模型发生严重损坏。
- 关闭时，请务必先关闭接收机电源，然后关闭发射机。如果关闭发射机电源时接收机仍然在工作，将有可能导致遥控设备失控或者引擎继续工作而引发事故。
- 当遥控距离较远时，有发生失控的可能，请适当缩短遥控距离。
- 操控时，请先确认模型所有舵机的动作方向与操控方向一致。如果不一致，请调整好正确的方向。

产品简介

产品介绍

上世纪五六十年代，二战的硝烟消失殆尽，美国步入“黄金时代”。人们开始憧憬安逸的生活，或者说奢逸的生活。在这个繁荣发展的时代，即便是造一辆卡车，也务求即使不能珠光宝气也要走细节流。雪佛兰阿帕奇就是这种思潮下的代表作。

雪佛兰卡车的发展史可以追溯到1918年，在一个世纪的卡车产品制造历史中，有很多型号如今已经成为文化符号。FMS获得雪佛兰公司的授权，将1959年的阿帕奇6轮皮卡转化成1:18遥控模型车。在还原度方面，FMS 1:18遥控模型忠实地表达了阿帕奇原车的结构和丰富细节。硬塑胶仿真车身、下沉车架、精确比例冲压底板货斗（方便搭载各类1:18的仿真零件如摩托车、皮划艇以及各种露营装备）、宽敞驾驶室（像真中控台、方向盘、长凳座椅）不过是起跑线，环绕式设计挡风玻璃和大后窗、古典金属电镀格栅、电镀后视镜和玻璃镜片、电镀轮毂、联动灯组（大灯、转向灯、倒车灯）等细微之处则是FMS最真诚的致敬。

在性能方面，FMS秉承大道至简的原则，以玩家的标准设计研发阿帕奇。采用金属底盘、四连杆悬挂、六轮驱动、万向节传动……简单、坚固、可靠。此外，橡胶材质全地形耐磨软胎，兼顾公路和越野性能。

FMS 1:18雪佛兰阿帕奇，一辆既可以锁进玻璃柜里借以怀念旧日时光，也可以带出去“野”的六驱遥控车。

产品特点

- 组装完成品
- 6轮全时驱动
- 金属齿转向舵机
- 4连杆悬挂
- 高强度混纤尼龙一体成型车架
- 喷涂完成的注塑硬塑胶车壳
- 活动引擎盖
- 遥控灯光系统
- 原创个性化贴纸
- 电镀像真细节
- 050超高扭力有刷电机
- 2.4Hz遥控控制

发射机介绍

FS-R4A1采用ANT协议，是一款电调、LED灯组控制板三合一接收机，外置单天线，可输出PWM信号和车灯控制信号，能够实现双向传输，采用自动对码，设计小巧紧凑，可适配多种车型使用。

发射机概览

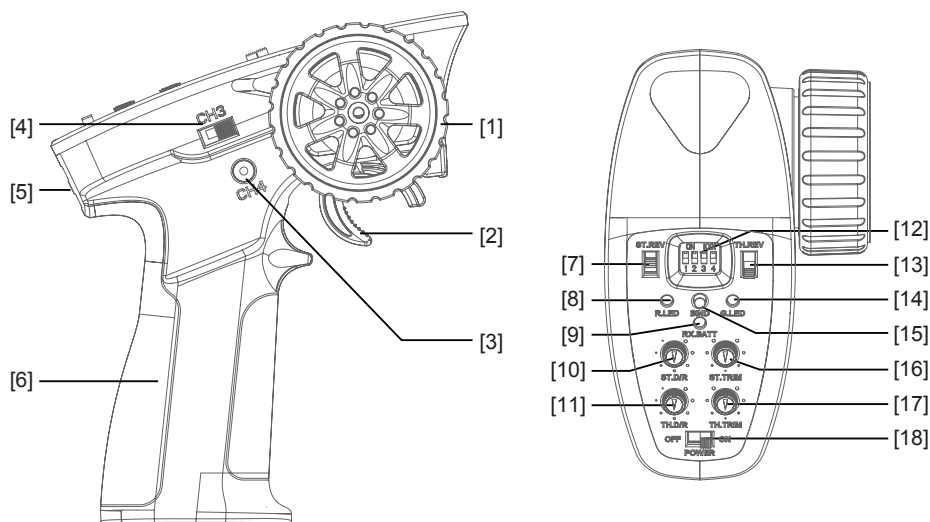

[1]	方向手轮，左右各35度 (CH1)	[10]	方向舵量调节旋钮 (ST.D/R)
[2]	油门扣机，前25度后12.5度 (CH2)	[11]	油门舵量调节旋钮 (TH.D/R)
[3]	按键开关CH4 (单击为灯效功能，长按为其他功能，如二/四驱切换。)	[12]	拨码开关 (切换电调的工作模式)
[4]	三档拨动开关 (CH3)	[13]	油门倒置开关 (TH.REV)
[5]	挂绳孔	[14]	状态指示灯绿色LED(G.LED)
[6]	手柄，4*AAA电池仓	[15]	对码按键 (BIND)
[7]	方向倒置开关 (ST.REV)	[16]	方向微调旋钮 (ST.TRIM)
[8]	电源指示灯红色LED(R.LED)	[17]	油门微调旋钮 (TH.TRIM)
[9]	电调电池电量显示双色灯 (RX.BATT)	[18]	电源开关

*[3]按键开关CH4,(长按为两/四驱切换)部分车型无此功能

接收机概览

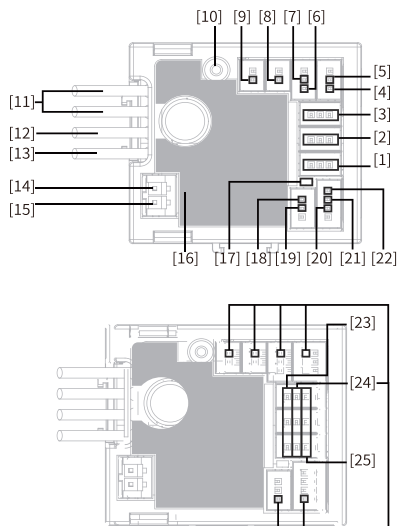

- | | |
|------------|---------------|
| [1]CH1通道接口 | [14]马达接口“ M+” |
| [2]CH3通道接口 | [15]马达接口“ M-” |
| [3]CH4通道接口 | [16]贴纸 |
| [4]左转灯接口 | [17]LED指示灯 |
| [5]前灯接口 | [18]左转灯接口 |
| [6]右转灯接口 | [19]右转灯接口 |
| [7]前灯接口 | [20]倒车灯接口 |
| [8]雾灯接口 | [21]刹车灯接口 |
| [9]雾灯接口 | [22]尾灯接口 |
| [10]天线 | [23]通道信号端 |
| [11]电源开关 | [24]电源正极 |
| [12]电池线正极 | [25]电源负极 |
| [13]电池线负极 | |

产品规格

- 产品型号：FS-R4A1
- 适配遥控器：FS-MG41
- 适合机种：车
- 通道个数：4
- 车灯接口数：7
- 无线频率：2.4GHz ISM
- 无线协议：ANT(自动调频数字系统)
- 无线类型：单天线
- 输入电源：Lipo(2S)/NiMH(5~7Cell)
- BEC输出：6V/1A
- 持续/峰值电流：10A/50A
- 数据输出：PWM
- 温度范围：-10°C—+60°C
- 湿度范围：20%~95%
- 防水等级：PPX4
- 在线更新：无
- 外形尺寸：33mm*30mm*12mm(不含电容)
- 机身重量：11g左右
- 认证：CE,FCC ID:N4ZR4A10

对码

本款接收机上电即自动进入对码状态。

按住遥控器的对码键并开机，即进入对码状态，此时G.LED快闪，松开“BIND”键。

- 1.接收机上电等待1秒没有连接将自动进入对码；
- 2.对码成功后，接收机LED指示灯常亮；

注：(1)对码时请先将遥控器进入对码状态，再将接收机进入对码状态，若10s内对码没有完成，接收机指示灯进入慢闪状态；(2)如果重新对码成功，车灯的所有设置将恢复默认值。

电调保护功能

本款接收机具有上电自检显示、过热报警提示、电压过低/高报警提示等多种提示功能。

- 自检显示：接收机上电瞬间所有车灯长亮1S；
- 过热报警：检测到电调内部温度超过110°C时，马达无输出，所有车灯快闪提示；当温度低于70°C时恢复正常输出；
- 电压过低/高报警：接收机进入电压过低保护时，马达无输出，所有车灯慢闪提示；接收机进入电压过高保护时，所有通道无输出，所有车灯快闪提示。

电调功能使用说明

1.连接相关设备：

连接前请确认电调开关处于关闭（OFF）状态，将电机与电调的M+/M-相连接，舵机接到电调3Pin排针接口上（“-” “+” “S” 相对应），电池与电调输入正负极对应相接。

2.正常开机，识别油门中点：

上面第一步相关设备连接好后，先打开遥控器，并将遥控器油门扳机置于中点位置（自然状态）。最后一步打开电调开关，接收机重新上电自动识别电池类型后方可运行。注意：a.电调开机后必须等到自检完成后方可运行（大约3秒），否则可能无法正常动作；b.若开机后无动力输出，请查看遥控器油门微调是否置于“0”位置，接收机重启可自动识别微调油门中点；c.若运行时发现电机转向不对，将电调接电机的两根线互换位置即可；d.为了一切正常，请养成先打开遥控器最后打开电调开关以及先关闭电调开关最后关闭遥控器的习惯。

注：关于电调的电池类型、拖刹力度和运行模式的设置详见相关配套遥控器说明书相关章节。









失控保护

此功能用于当接收机无法正常收到遥控器的信号不受控制时，保护模型和操作人员的安全。该接收机默认为油门通道固定为失控进入刹车状态，其他通道失控后接收机无信号输出，如若在遥控器上进行设置，则按照设置值输出。

注意事项：

- 使用前必须确保本产品与模型安装正确，否则可能导致模型发生严重损坏。
- 请查看各动力设备以及车架说明书，确保动力搭配合理，避免因错误的搭配导致动力系统损坏。
- 勿使系统的外部温度超过90°C /194 °F,高温将会毁坏动力系统。
- 关闭时，请务必先关闭接收机电源，然后关闭遥控器。如果关闭遥控器电源时接收机仍然在工作，将有可能导致遥控设备失控或者引擎继续工作而引发事故。
- 使用完毕后，若长时间不玩车，切记断开电池与电调的连接。如电池未断开，即使电调开关处于关闭状态，电调也会一直消耗电能（只是非常小），长时间连接电池最终会被过放，进而导致电池或电调出现故障。我们不对因此而造成的任何损害负责！
- 确保接收机安装在远离电机或电子噪声过多的区域。
- 接收机天线需远离导电材料，例如金属棒和碳物质。为了避免影响正常工作，请确保接收机天线和导电材料之间至少有1厘米以上的距离。
- 准备过程中，请勿连接接收机电源，避免造成不必要的损失。

电调参数设置

Running Mode	Battery Type	Drag Brake	
 FWD/REV/BRK	 Lipo	 0%	 75%
 FWD/REV	 NiMH	 50%	 100%

拨码开关标识

发射机上的拨码开关用于设置电调参数，即拨码开关位于不同位置对应参数值不同。

设置方法

该电调有三个参数项可以设置，分别是“运行模式(Running Mode)”、“电池类型(Battery Type)”“拖刹力度(Drag Brake)”。遥控器面板上有一列编号为1234的拨码开关，通过上下拨动可以实现对上述参数项的设置，具体操作如下：

当遥控器面板上编号为1的拨码开关位于下侧时，表示运行模式设置为前进后退带刹车(FWD/ REV/BRK)。

当遥控器面板上编号为1的拨码开关位于上侧时，表示运行模式设置为直接正反转(FWD/REV)。

当遥控器面板上编号为2的拨码开关位于下侧时，表示电池类型设置为锂电池(Lipo)。

当遥控器面板上编号为2的拨码开关位于上侧时，表示电池类型设置为镍氢(NiMH)。

当遥控器面板上编号为3的拨码开关位于下侧时，编号为4的拨码开关位于下侧时，表示拖刹力度为0%。

当遥控器面板上编号为3的拨码开关位于下侧时，编号为4的拨码开关位于上侧时，表示拖刹力度为50%。

当遥控器面板上编号为3的拨码开关位于上侧时，编号为4的拨码开关位于下侧时，表示拖刹力度为75%。

当遥控器面板上编号为3的拨码开关位于上侧时，编号为4的拨码开关位于上侧时，表示拖刹力度为100%。

参数解释

1.运行模式(Running Mode)

前进后退带刹车(FWD/REV/BRK)：此模式采用的是“双击式倒车”，即油门扳机在第一次从中点区域推至反向区域时，电机只是刹车不会产生倒车动作；当油门扳机回到中点区域并第二次推至反向区域时则产生倒车动作。此模式适用于一般车型。

直接正反转(FWD/REV)：此模式采用“单击式”倒车方式，即油门扳机从中点区域推至反向区域时电机立即产生倒车动作，该模式一般用于攀爬车等特种车辆。

设置该参数的方法：

当遥控器面板上编号为1拨码开关位于下侧，表示运行模式设置为前进后退带刹车(FWD/REV/BRK)。

当遥控器面板上编号为1拨码开关位于上侧，表示运行模式设置为直接正反转(FWD/REV)。

2.电池类型(Battery Type)

有锂电和镍氢两种选择，根据实际使用情况设置即可。设置该参数的方法：

当遥控器面板上编号为2的拨码开关位于下侧时，表示电池类型设置为锂电池。

当遥控器面板上编号为2的拨码开关位于上侧时，表示电池类型设置为镍氢。

3.拖刹力度(Drag Brake)

拖刹是指当油门扳机从正向区域或反向区域转入中点区域内时，对电机产生一定的刹车力，这样做可以模拟有刷电机的碳刷对电机转子的阻力，适合减速入弯及攀爬车应用。

设置该参数的方法：

当遥控器面板上编号为3的拨码开关位于下侧，编号为4的拨码开关也位于下侧，表示拖刹力度为0%。

当遥控器面板上编号为3的拨码开关位于下侧，编号为4的拨码开关位于上侧时，表示拖刹力度为50%。

当遥控器面板上编号为3的拨码开关位于上侧，编号为4的拨码开关位于下侧时，表示拖刹力度为75%。

当遥控器面板上编号为3的拨码开关位于上侧，编号为4的拨码开关位于上侧时，表示拖刹力度为100%。







灯光功能

按钮	车灯位置	功能	开机默认 关闭	按次数					控制方式	备注
				I	II	III	IV	V		
CH4	车头部灯	前白灯常亮		关闭	•	关闭	关闭	关闭		
		前白灯高光 常亮		关闭	关闭	•	•	关闭		
	车尾部灯	尾灯常亮		关闭	•	•	•	关闭		
	转向灯	转向橙灯		关闭	○	○	○	○	方向联动控制	左转向时左边3个转向灯，自动闪烁，闪烁的频率是1秒，即亮0.5秒，灭0.5秒。
		转向橙灯		关闭	○	○	○	○	方向联动控制	右转向时左边3个转向灯，自动闪烁，闪烁的频率是1秒，即亮0.5秒，灭0.5秒。

使用前准备

开始操作前，请按照本章的顺序和指引安装电池、连接设备。

★ 发射机电池安装

 危险	仅使用厂家指定的电池。
 危险	请勿打开、拆卸或自行维修电池。
 危险	请勿挤压、刺穿或接触电池的金属端子。
 危险	请勿将电池置于高温环境或液体中。
 危险	如果不按照说明方法操作，可能导致操作者或他人遭受较大伤害。
 危险	请将电池存放在干燥阴凉的环境中。
 危险	如果电池损坏，请立即停止使用。

电池类型使用：AAA电池

请按照以下步骤安装发射机电池：

1. 打开电池仓盖。
2. 将4颗电量充足的AAA电池装入电池仓内，确保电池上的金属端子与电池仓内的金属端子接触。
3. 盖好电池仓盖。

低电量报警：当电量低于4.2V时，面板上的LED慢闪报警提示。

操作指引

准备操作完成后，您可以按照本章指引开始使用本产品。

1. 自动对码（发射机和接收机在出厂前已对码成功）

如需更换其他的发射机或接收机请按照如下步骤进行对码:

1. 按住Bind键后，发射器电源打开，对码模式，灯不停闪亮；
2. 接收板电源打开，前车灯不停闪亮，进入对码模式；
3. 当对码成功，发射机灯全亮，车上面的灯全部关闭；

注意：对码时请先操作发射机进入对码状态，再操作接收机进入对码状态。

2. 关机

请按照以下步骤关机：

1. 断开接收机电源。
2. 将开关拨到 [OFF] 位置，使发射机关闭。

 **危险** 关闭时，请务必先关闭接收机电源，再关闭发射机，否则可能导致模型损坏、人员受伤。

产品规格

1. 发射机规格

产品型号	FS-MG41
通道个数	4
适配模型	车、船
支持电池节数	4节AAA电池
无线频率	2.4GHzISM
发射功率	<20dBm
无线协议	ANT
遥控距离	>150m（空旷无干扰地面距离）
通道分辨率	1024 级
电池	6V DC 1.5AAA*4
充电接口	无
续航时间	依电池类型
低电压报警	<4.2V
天线类型	内置单天线
数据接口	无
温度范围	-10°C—+60°C

湿度范围	20—95%
在线更新	无
遥控器颜色	黑
外形尺寸	118mm x 73mm x 145mm
机身重量	130g
认证	CE,FCC ID:N4ZMG400

油门扳机位置

中位



前进方向的顶端

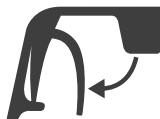

后退方向的顶端



电池充电

- 1.将充电器连接到USB端口，然后将电池连接到充电器电源线上。
- 2.充电时，LED灯状态为红色，充电完成时，LED灯状态为绿色。
- 3.请勿在无人看管的情况下充电!
- 4.如果发现电池或充电器温度过热，请立即断开电池和充电器，因为这可能是由内部短路引起的。

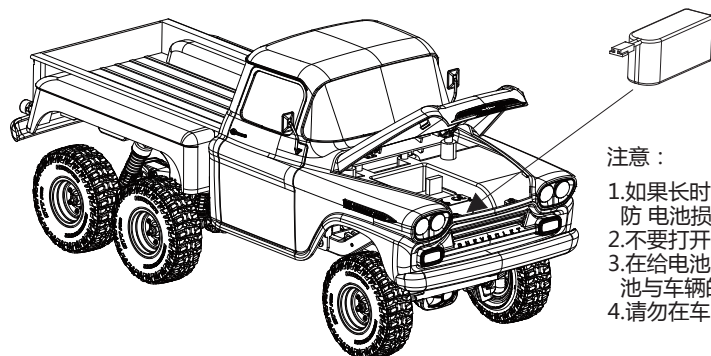
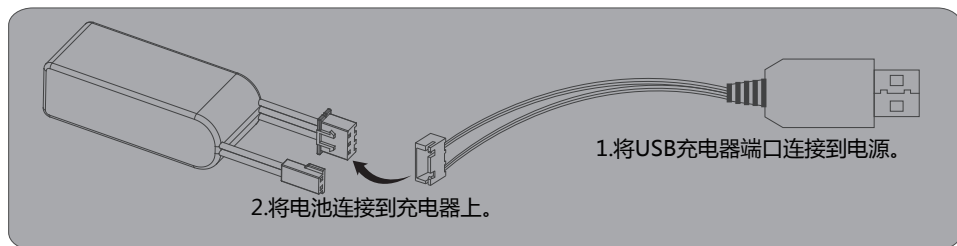

注意：

- 1.如果长时间不用，请拔下电池，以防电池损坏。
- 2.不要打开、拆解或试图维修电池。
- 3.在给电池充电之前，需要先断开电池与车辆的连接。
- 4.请勿在车内给电池充电。

配件列表

C2193	11820 引擎盖	C2206	11820 车窗
C2194	11820 前/后灯杯组	C2063	避振器 13圈弹簧
C2195	11820 引擎盖连接座	C2207	11820 连杆
C2196	11820 后视镜	C2066	球轴
C2197	11820 防撞	C2067	C座胶件
C2198	11820 灯镜片	C2208	前/后桥胶件
C2199	11820 车壳	C2069	舵机摇臂
C2200	11820 扶手	C2209	镜片
C2045	Teraz 轮胎	C2071	车轮六角接合件
C2201	星状风格轮毂 电镀	C2073	轴承
C2052	7.4V 380maH电池	C2074	后轮轴
C2202	11820 灯线组	C2075	前轮转向轴
C2051	USB 平衡充电器 7.4V 1000mA	C2076	牙箱胶件
C2049	050电机 + 电机齿	C2021	1kg 舵机
C2057	塑胶齿轮	C2133	M4球头
C2203	11820 传动轴	C2120	MG41 + R4A 发射器+二合一电调接收器
C2204	11820 螺丝	C2121	R4A 二合一电调接收器
C2205	11820桥轴金属齿轮	C2122	MG41 发射器
C2060	螺母 M2 & M2.5	C2210	11820 仪表盘

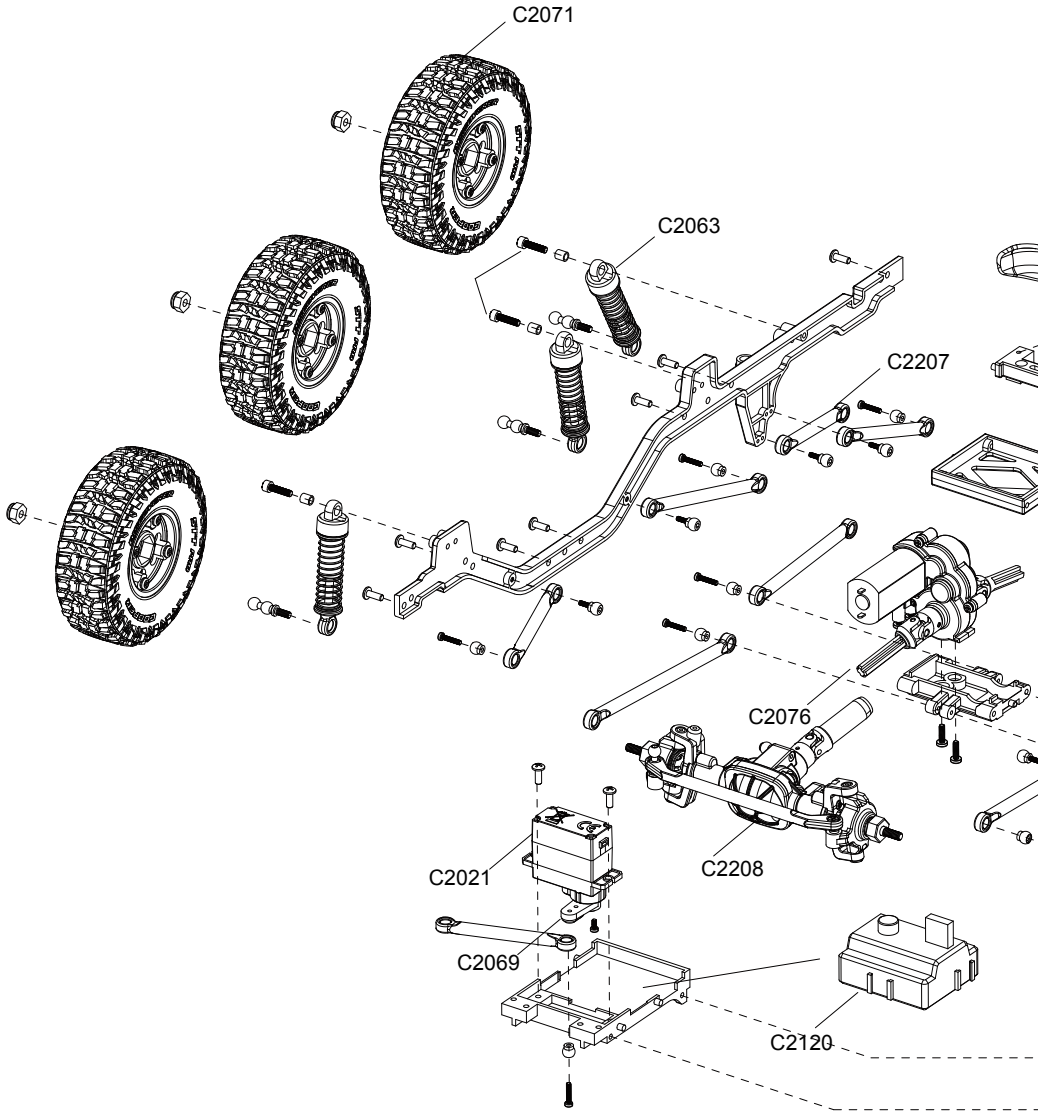

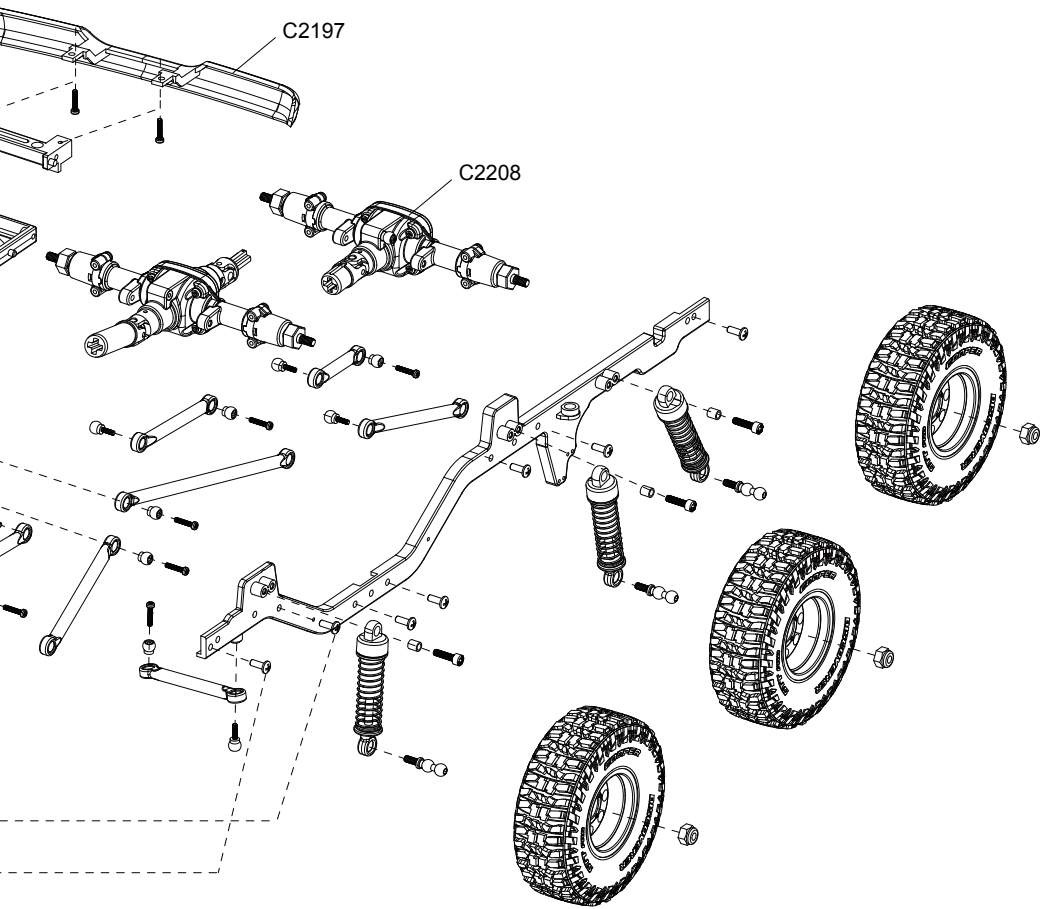

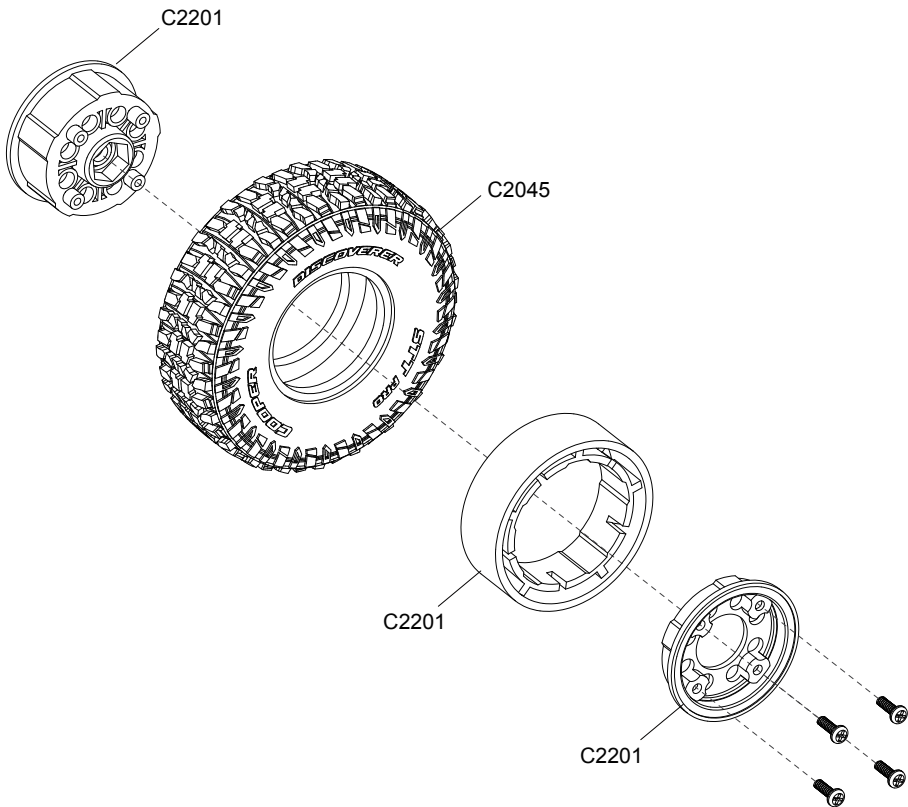

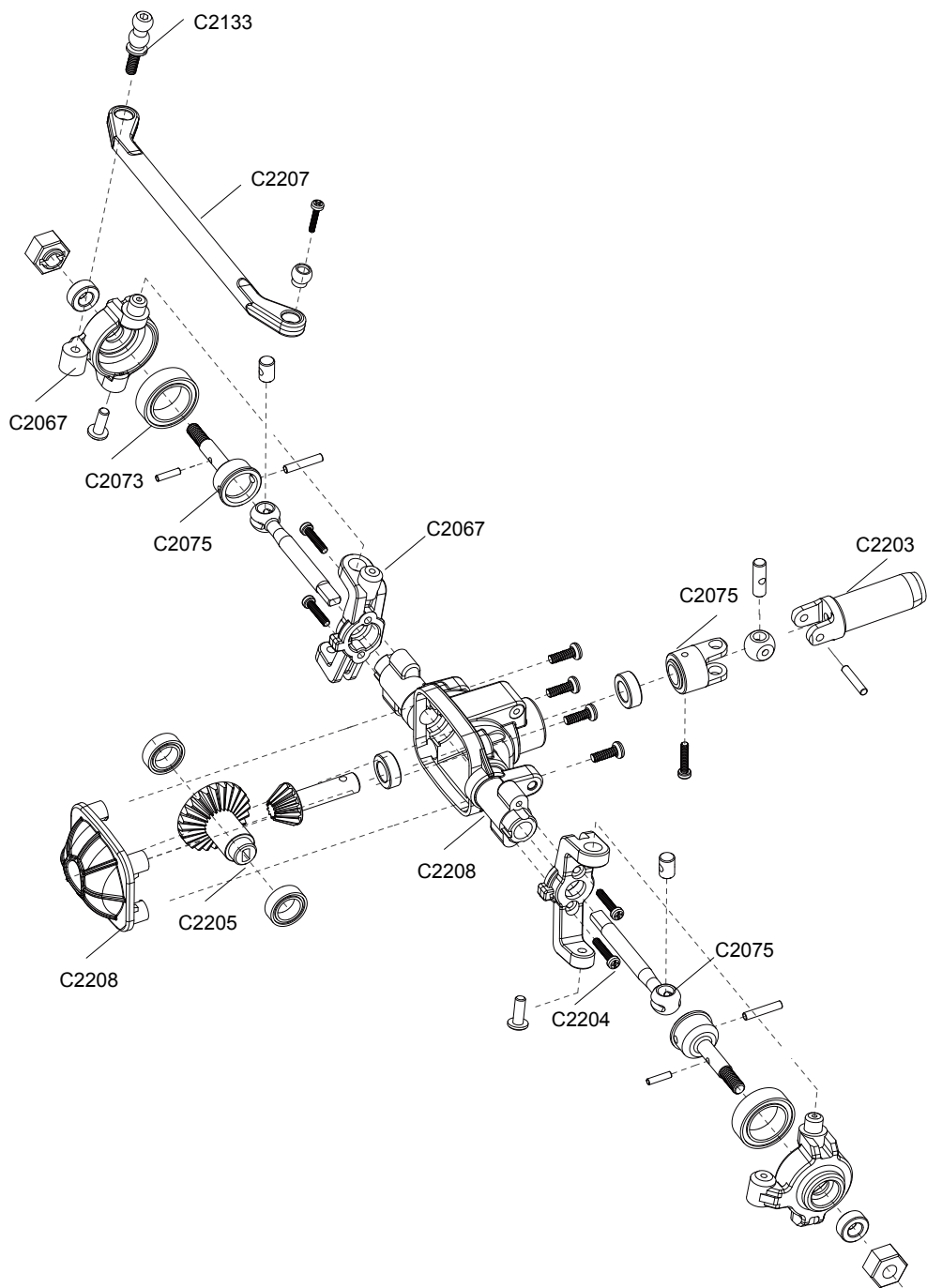

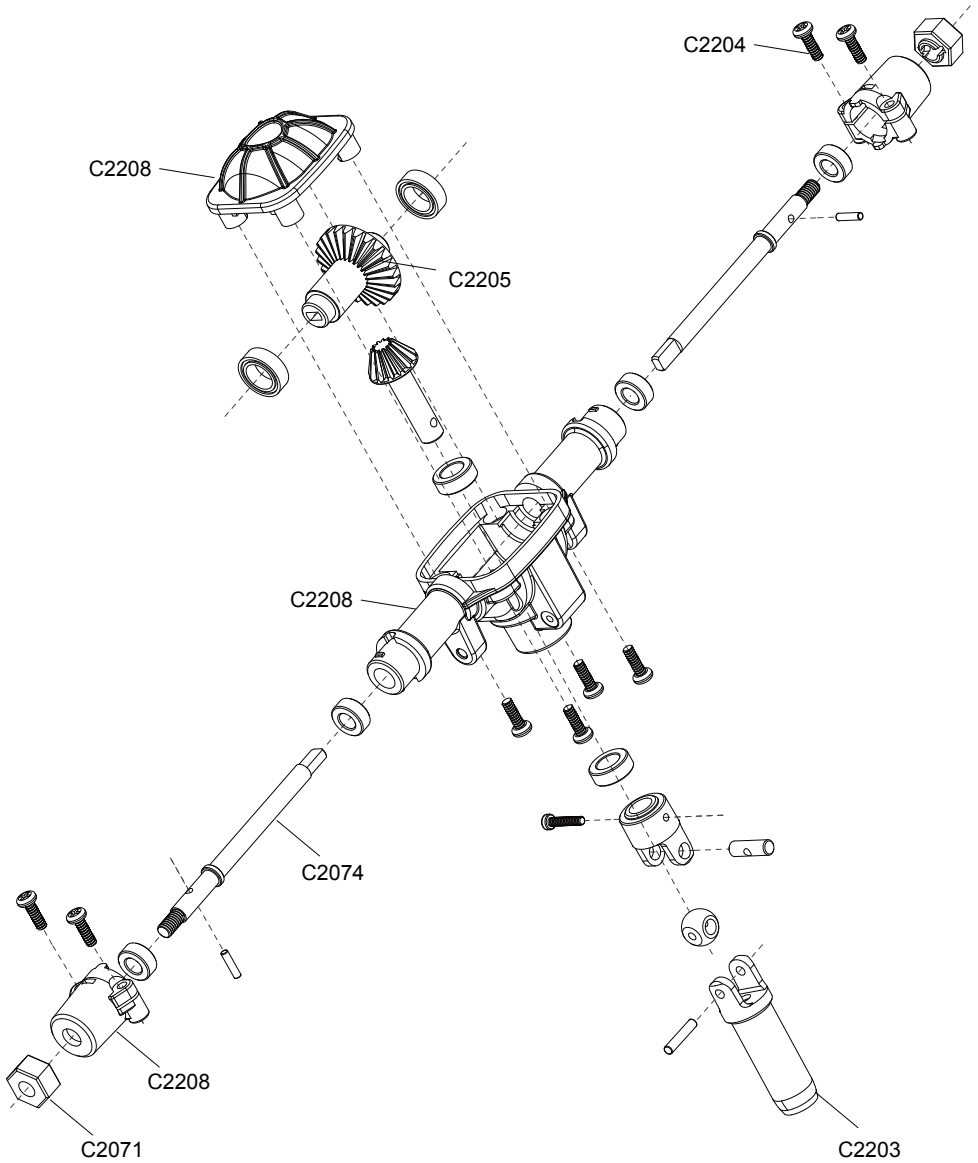

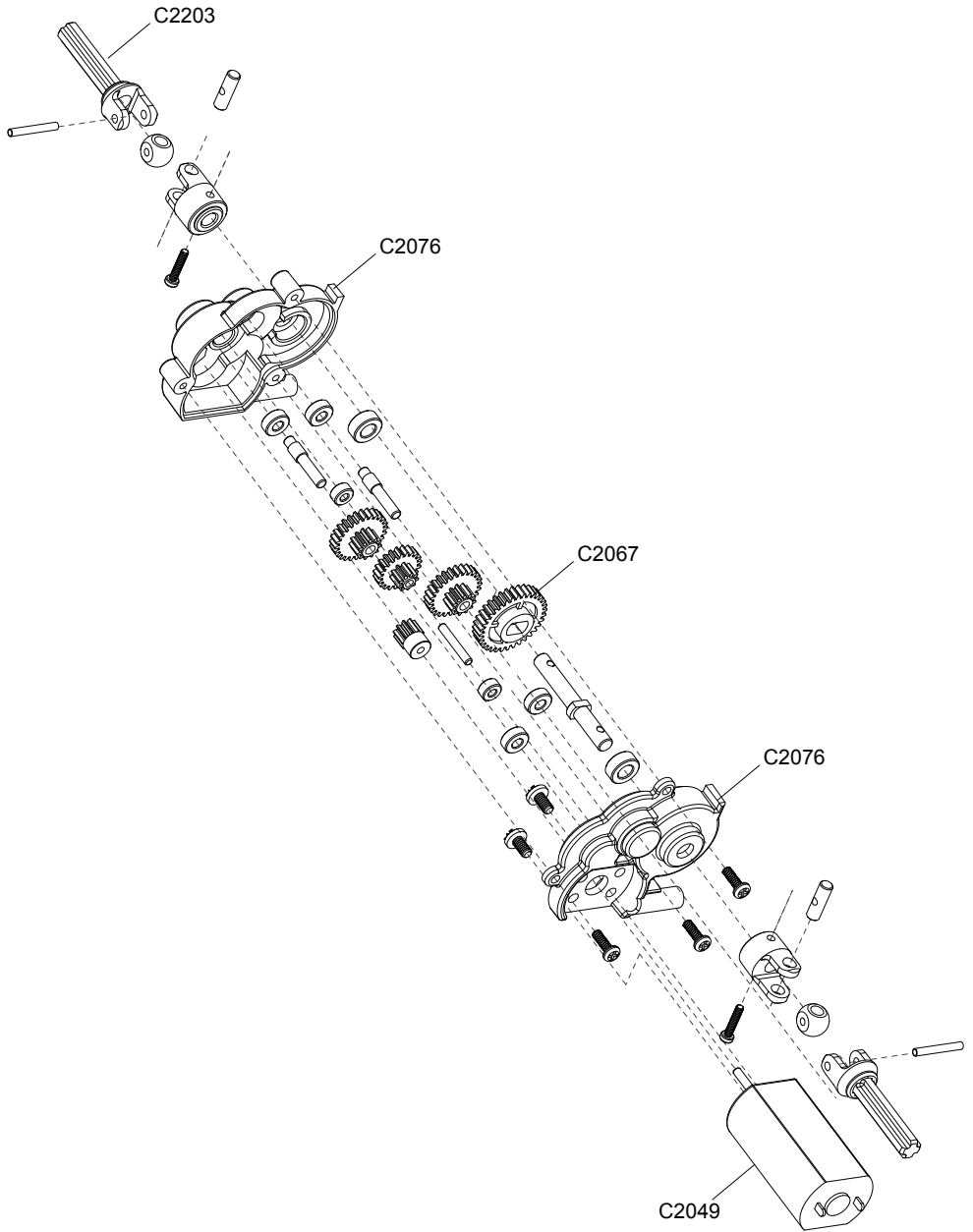

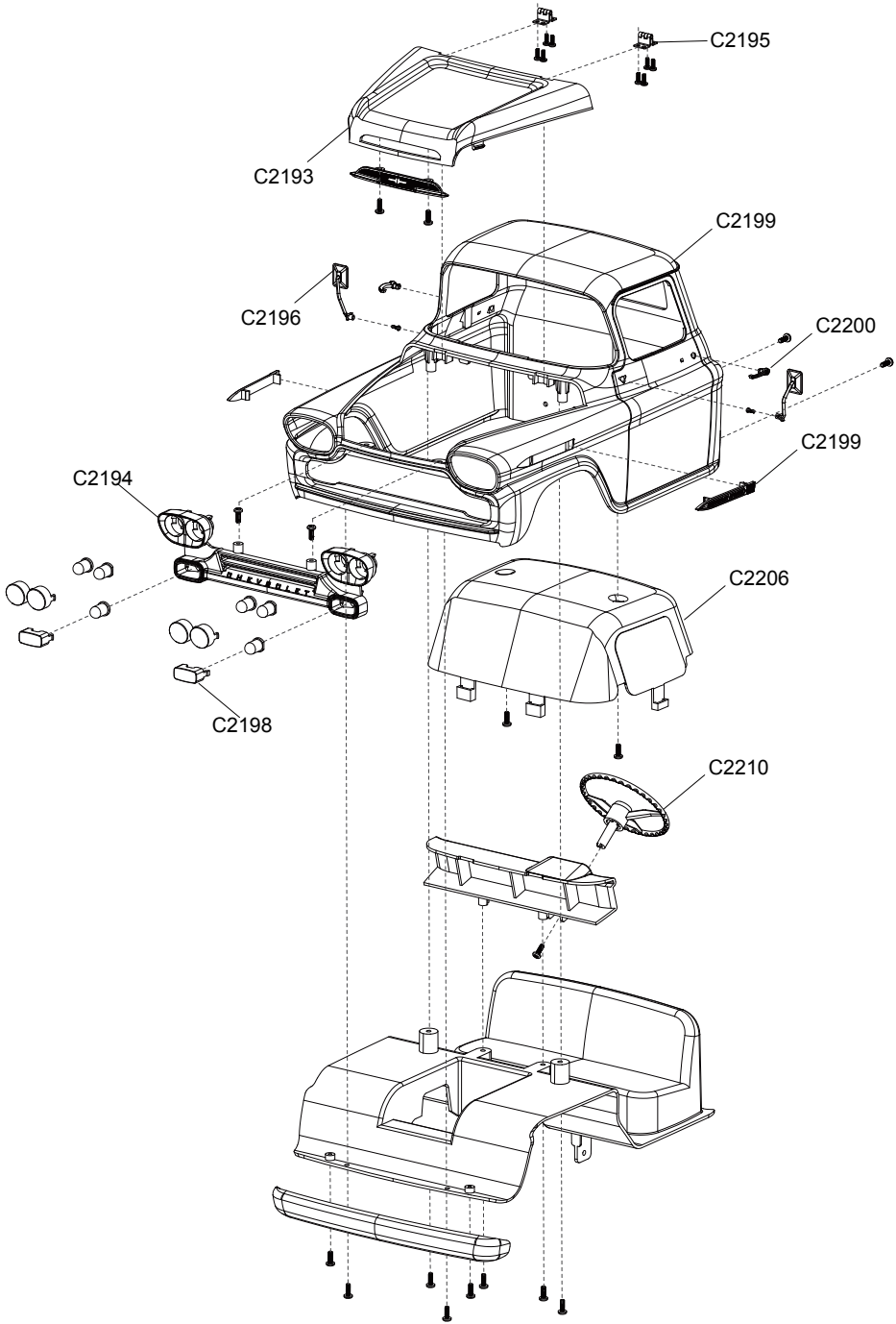

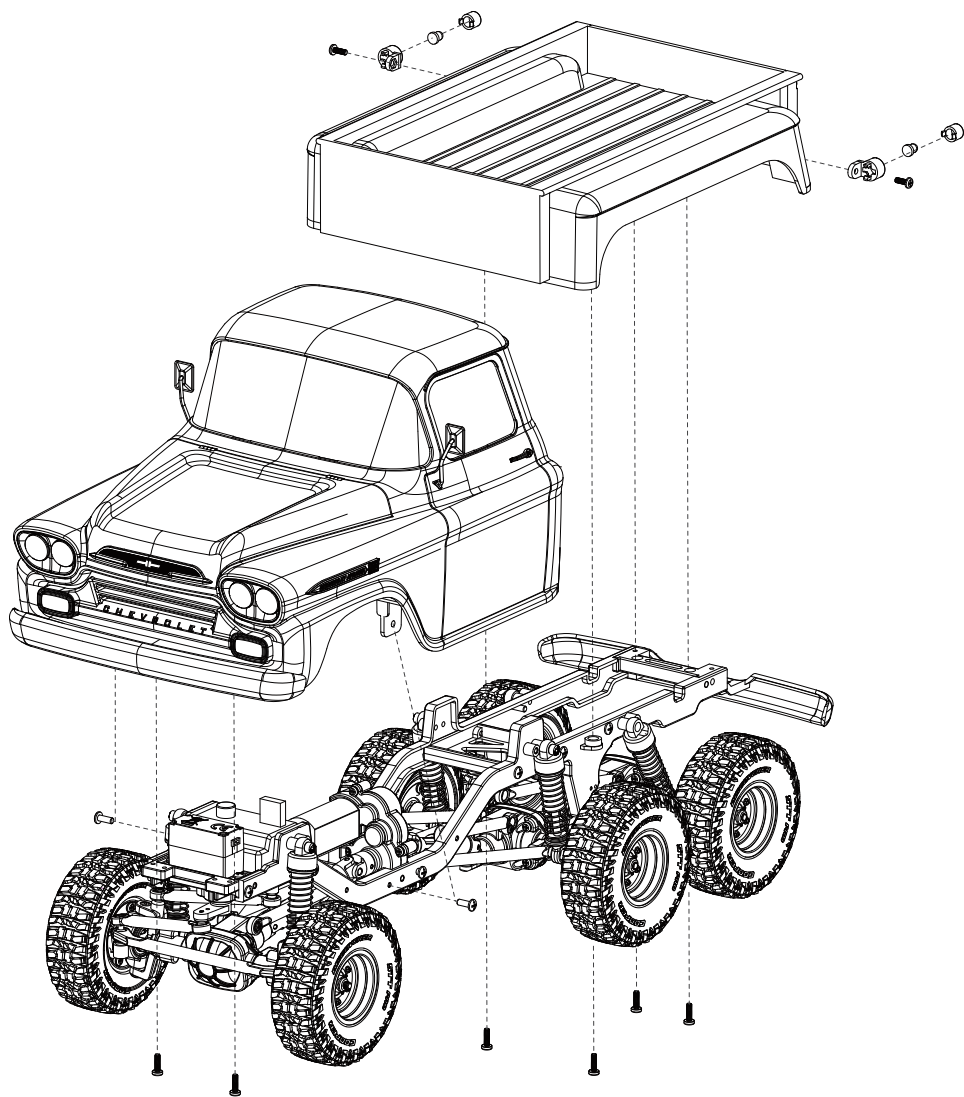



MADE IN CHINA