

F-16 Thunderbirds 70mm EDF

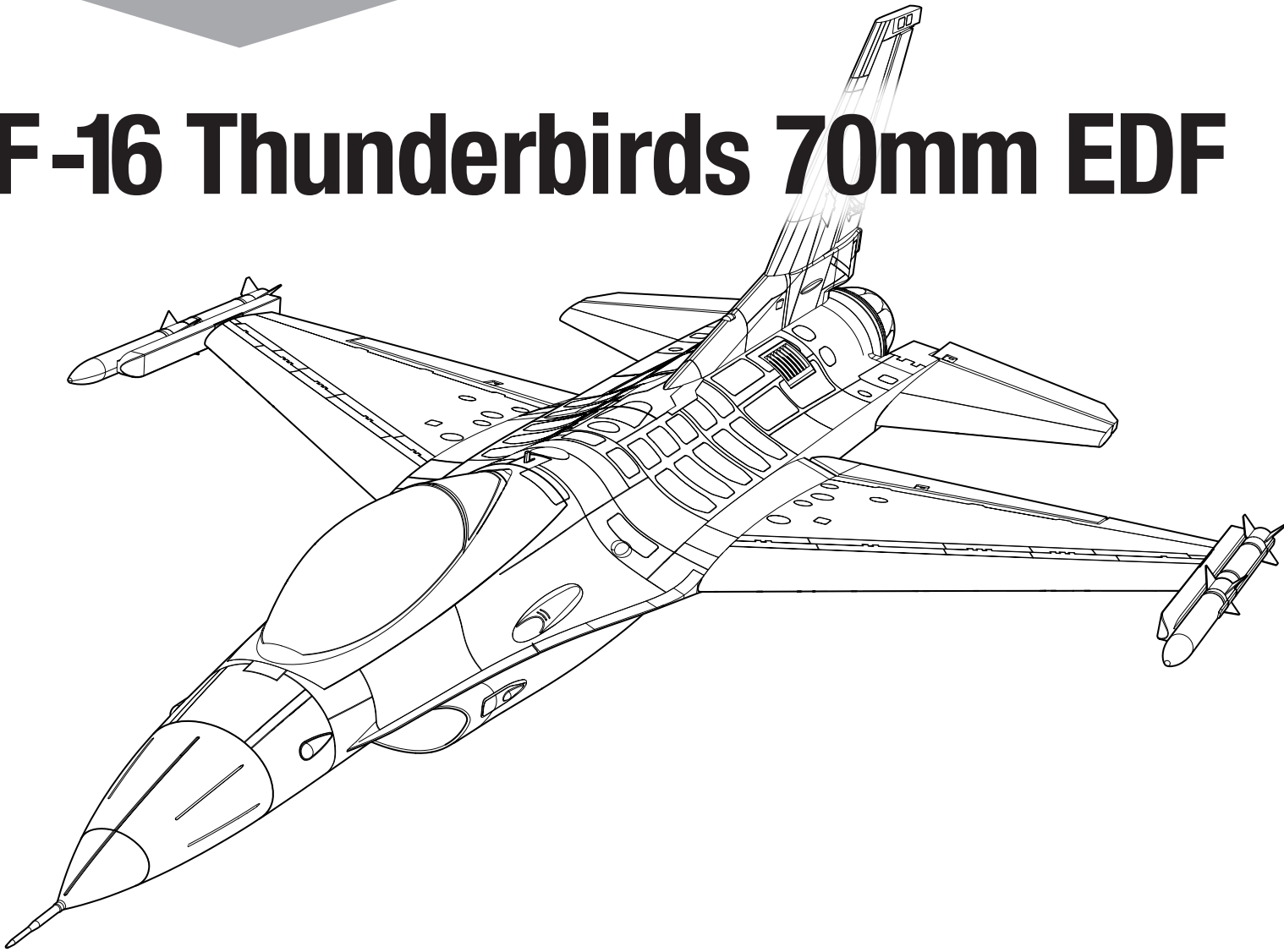

Instruction Manual
Bedienungsanleitung
Manuel d'utilisation
Manuale di Istruzioni

Scan the QR code and select the Manuals and Support quick links from the product page for the most up-to-date manual information.
Scannen Sie den QR-Code und wählen Sie auf der Produktseite die Quicklinks Handbücher und Unterstützung, um die aktuellsten Informationen zu Handbücher.
Scannez le code QR et sélectionnez les liens rapides Manuals and Support sur la page du produit pour obtenir les informations les plus récentes sur le manuel.
Scannerizzare il codice QR e selezionare i Link veloci Manuali e Supporto dalla pagina del prodotto per le informazioni manuali più aggiornate.



EFL178500

NOTICE

All instructions, warranties and other collateral documents are subject to change at the sole discretion of Horizon Hobby, LLC. For up-to-date product literature, visit horizonhobby.com or towerhobbies.com and click on the support or resources tab for this product.

MEANING OF SPECIAL LANGUAGE

The following terms are used throughout the product literature to indicate various levels of potential harm when operating this product:

WARNING: Procedures, which if not properly followed, create the probability of property damage, collateral damage, and serious injury OR create a high probability of superficial injury.

CAUTION: Procedures, which if not properly followed, create the probability of physical property damage AND a possibility of serious injury.

NOTICE: Procedures, which if not properly followed, create a possibility of physical property damage AND little or no possibility of injury.



WARNING: Read the ENTIRE instruction manual to become familiar with the features of the product before operating. Failure to operate the product correctly can result in damage to the product, personal property and cause serious injury.

This is a sophisticated hobby product. It must be operated with caution and common sense and requires some basic mechanical ability. Failure to operate this Product in a safe and responsible manner could result in injury or damage to the product or other property. This product is not intended for use by children without direct adult supervision. Do not use with incompatible components or alter this product in any way outside of the instructions provided by Horizon Hobby, LLC. This manual contains instructions for safety, operation and maintenance. It is essential to read and follow all the instructions and warnings in the manual, prior to assembly, setup or use, in order to operate correctly and avoid damage or serious injury.

AGE RECOMMENDATION: Not for children under 14 years. This is not a toy.

Safety Precautions and Warnings

As the user of this product, you are solely responsible for operating in a manner that does not endanger yourself and others or result in damage to the product or the property of others.

- Always keep a safe distance in all directions around your model to avoid collisions or injury. This model is controlled by a radio signal subject to interference from many sources outside your control. Interference can cause momentary loss of control.
- Always operate your model in open spaces away from full-size vehicles, traffic and people.
- Always carefully follow the directions and warnings for this and any optional support equipment (chargers, rechargeable battery packs, etc.).
- Always keep all chemicals, small parts and anything electrical out of the reach of children.
- Always avoid water exposure to all equipment not specifically designed and protected for this purpose. Moisture causes damage to electronics.
- Never place any portion of the model in your mouth as it could cause serious injury or even death.
- Never operate your model with low transmitter batteries.
- Always keep aircraft in sight and under control.
- Always use fully charged batteries.
- Always keep transmitter powered on while aircraft is powered.
- Always remove batteries before disassembly.
- Always keep moving parts clean.
- Always keep parts dry.
- Always let parts cool after use before touching.
- Always remove batteries after use.
- Always ensure failsafe is properly set before flying.
- Never operate aircraft with damaged wiring.
- Never touch moving parts.



WARNING AGAINST COUNTERFEIT PRODUCTS: If you ever need to replace your Spektrum receiver found in a Horizon Hobby product, always purchase from Horizon Hobby, LLC or a Horizon Hobby authorized dealer to ensure authentic high-quality Spektrum product. Horizon Hobby, LLC disclaims all support and warranty with regards, but not limited to, compatibility and performance of counterfeit products or products claiming compatibility with DSM or Spektrum technology.

Registration

Register your product today to join our mailing list and keep up to date with product updates, offers and E-flite® news.



Table of Contents

Required Tools	3
SAFE® Select Technology (BNF Basic)	4
Transmitter Setup (BNF Basic).....	4
Model Assembly	5
Scale Accessories <i>Optional</i>	7
Battery Installation and ESC Arming	7
SAFE® Select Switch Designation	9
Control Horn and Servo Arm Settings	9
Center of Gravity (CG)	10
Control Direction Test.....	10
In Flight Trimming (BNF Basic)	11
Flying Tips and Repairs	11
Post Flight.....	11
PNP Receiver Selection and Installation	12
Motor Service	12
Troubleshooting Guide AS3X	13
Troubleshooting Guide	13
Replacement Parts.....	14
Important Federal Aviation Administration (FAA) Information.....	14
AMA National Model Aircraft Safety Code.....	14
Recommended Equipment.....	14
Optional Accessories.....	14
Limited Warranty	15
Contact Information	15
FCC Information.....	16
IC Information	16
Compliance Information for the European Union.....	16

Specifications

Wingspan	32" (813mm)
Length	49.53" (1258mm)
Weight	Without Battery: 73.7oz (2090g) With Recommended 6S 3200mAh Flight Battery: 5.6lbs (2570g)

Included Equipment

Receiver*	Spektrum™ AR631 6CH AS3X®/SAFE® Receiver (SPMAR631)
ESC	Avian 85-Amp Smart® Lite Brushless ESC, 3S-6S IC5 (SPMXAE85C)
Motor	Brushless In-runner Motor; 3060-KV1900 4-pole (SPMXAM3000)
Fan	70mm Ducted Fan (EFLA7012DF)
Servos	(6) 9g Digital Servo, Metal Gear (SPMSA335) (1) 9g Digital Servo Metal Gear Reverse (SPMSA335R) (right elevator)

*These components are not included with the Plug and Play (PNP) version of this product.

Recommended Equipment

Transmitter	NX6 6 Channel Transmitter Only (SPMR6775)
Flight Battery	3200mAh 6S 22.2V Smart 30C; IC5 (SPMX32006S30)
Battery Charger	S1100 G2 1x100W AC Smart Charger (SPMXC2080)

Optional Accessories

SPMR8200	NX8 8 Channel Transmitter Only
SPMXC2000	S2100 G2 2x100W AC Smart Charger
SPMX32006S50	3200mAh 6S 22.2V Smart 50C; IC5
SPMX40006S50	4000mAh 6S 22.2V Smart 50C; IC5
SPMX40006S30	4000mAh 6S 22.2V Smart 30C; IC5
DYN1405	LiPo Charge Protection Bag, Large
SPM6722	Spektrum Single Aircraft TX Case

Required Tools

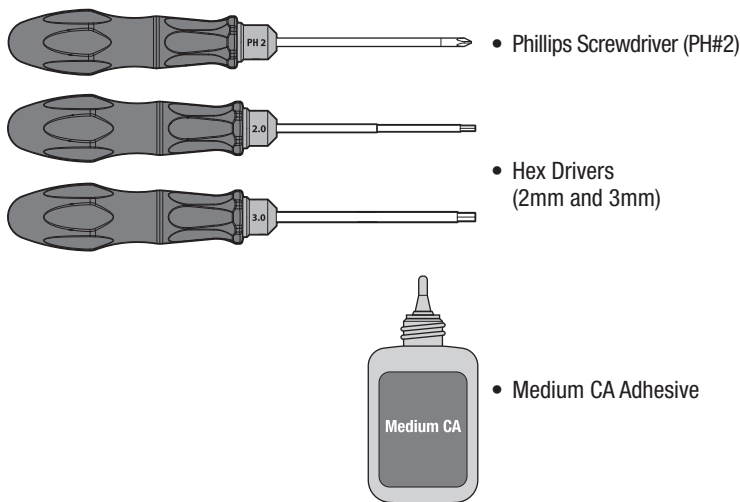

SAFE® Select Technology (BNF Basic)

The evolutionary SAFE® Select technology can offer an extra level of protection so you can perform the first flight with confidence. No complex transmitter programming is required. Just follow the simple bind process to make the SAFE Select system active. When activated, bank and pitch limitations keep you from over-controlling and automatic self-leveling makes recovery from risky or confusing attitudes as simple as releasing the sticks. In fact, with the aileron, elevator and rudder sticks in the neutral position, SAFE Select will automatically keep the airplane in a straight and level attitude.

Expand the advantage of what SAFE Select technology offers by assigning it to a switch. No transmitter programming is required and you'll be able to turn the system ON and OFF with the flip of a switch. Turn it OFF in flight for unrestricted aerobatic performance, and turn it back ON when a buddy wants to try out your cool aircraft. Turn SAFE Select ON for landings. It will help keep the correct pitch attitude and wings level during the final approach. Whether you're a beginner or an expert, SAFE Select can make your flights a great experience.

When the normal bind process is followed, the SAFE Select system is disabled, leaving specially tuned AS3X® technology in place to deliver a pure, unrestricted flight experience.

Transmitter Setup (BNF Basic)

IMPORTANT: After you set up your model, always rebind the transmitter and receiver to set the desired failsafe positions.

Dual Rates

Take first flights in low rate. For landings, use high rate elevator.

IMPORTANT: To ensure AS3X® technology functions properly, do not lower rate values below 50%. If lower rates are desired, manually adjust the position of the pushrods on the servo arm.

If oscillation occurs at high speed, refer to the Troubleshooting Guide for more information.

Expo

After first flights, you may adjust expo in your transmitter.

Retractable landing gear

Move the channel 5 (gear) switch to raise or lower the retractable landing gear.

Telemetry Alarms

Rx V: Min Rx V	4.2V
Smart ESC: Low Voltage Alarm	3.4V
Smart Battery: Startup Volt Minimum	4.0V

NX Series Transmitter Setup

1. Power ON your transmitter, click on scroll wheel, roll to **System Setup** and click the scroll wheel. Select **YES**.
2. Go to **Model Select** and choose **Add New Model** near the bottom of the list. Select **Airplane Model Type** by choosing airplane image, select **Create**.
3. Set **Model Name**: Input a name for your model file.
4. Go to **Aircraft Type** and scroll to the wing selection, choose **Wing: Normal; Tail: Normal**
5. Select **Main Screen**, Click the scroll wheel to enter the **Function List**.
6. Go to **Servo Setup, Reverse**: Reverse the **GER** channel
7. Go to the **Rates and Expo** menu to set **D/R** and **Expo**.
8. Set **Rates and Expo: Aileron**
Set **Switch: Switch F**
Set **High Rates: 100%, Expo 10%** — **Low Rates: 70%, Expo 5%**
9. Set **Rates and Expo: Elevator**
Set **Switch: Switch C**
Set **High Rates: 100%, Expo 10%** — **Low Rates 70%, Expo 5%**
10. Set **Rates and Expo: Rudder**
Set **Switch: Switch G**
Set **High Rates: 100%, Expo 10%** — **Low Rates 70%, Expo 5%**
11. Set **Throttle Cut, Switch: Switch H, Position: -100%**

DX Series Transmitter Setup

1. Power ON your transmitter, click on scroll wheel, roll to **System Setup** and click the scroll wheel. Select **YES**.
2. Go to **Model Select** and choose **Add New Model** at the bottom of the list. The system asks if you want to create a new model, select **Create**.
3. Set **Model Type**: Select **Airplane Model Type** by choosing the airplane. The system asks you to confirm model type, data will be reset. Select **YES**.
4. Set **Model Name**: Input a name for your model file.
5. Go to **Aircraft Type** and scroll to the wing selection, choose **Wing: Normal; Tail: Normal**
6. Select **Main Screen**, Click the scroll wheel to enter the **Function List**.
7. Go to **Servo Setup, Reverse**: Reverse the **GER** channel
8. Set **D/R (Dual Rate) and Expo: Aileron**
Set **Switch: Switch F**
Set **High Rates: 100%, Expo 10%** — **Low Rates: 70%, Expo 5%**
9. Set **D/R (Dual Rate) and Expo: Elevator**
Set **Switch: Switch C**
Set **High Rates: 100%, Expo 10%** — **Low Rates 70%, Expo 5%**
10. Set **D/R (Dual Rate) and Expo: Rudder**
Set **Switch: Switch G**
Set **High Rates: 100%, Expo 10%** — **Low Rates 70%, Expo 5%**
11. Set **Throttle Cut, Switch: Switch H, Position: -100%**

iX Series Transmitter Setup

1. Power ON your transmitter and begin once the Spektrum AirWare app is open.
Select the orange pen icon in the screen's upper left corner, the system asks for permission to **Turn Off RF**, select **PROCEED**.
2. Select the three dots in the upper right corner of the screen, select **Add a New Model**.
3. Select **Model Option**, choose **DEFAULT**, select **Airplane**. The system asks if you want to create a new acro model, select **Create**.
4. Select the last model on the list, named **Acro**. Tap on the word Acro and rename the file to a name of your choice.
5. Press and hold the back arrow icon in the upper left corner of the screen to return to the main screen.
6. Go to the **Model Setup** menu. Select **Aircraft Type**. The system asks for permission to **Turn Off RF**, select **PROCEED**.
Touch the screen to select **Wing/Tail Type**. Select **Wing: Normal; Tail: Normal**.
7. Press and hold the back arrow icon in the upper left corner of the screen to return to the main screen.
8. Go to the **Model Adjust** menu.
9. Go to **Servo Setup, Reverse**: Reverse the **GER** channel
10. Set **Dual Rates and Expo**: Select **Aileron**
Set **Switch: Switch F**
Set **High Rates: 100%, Expo 10%** — **Low Rates: 70%, Expo 5%**
11. Set **Dual Rates and Expo**: Select **Elevator**
Set **Switch: Switch C**
Set **High Rates: 100%, Expo 10%** — **Low Rates 70%, Expo 5%**
12. Set **D/R (Dual Rate) and Expo: Rudder**
Set **Switch: Switch G**
Set **High Rates: 100%, Expo 10%** — **Low Rates 70%, Expo 5%**
13. Set **Throttle Cut; Switch: Switch H, Position: -100%**

Model Assembly

Ventral Fin Installation

1. Wipe the mating surfaces on the ventral fins and the fan cover with a paper towel dampened with alcohol to remove any dust or loose paint before applying glue.
2. Use medium CA glue to attach the ventral fins to the fan cover. Apply a thin layer of medium CA glue only in the fin mounting cavity of the fan cover.

IMPORTANT: Do not apply glue to the front half of the ventral fin where they meet the fuselage. The ventral fins should only be glued to the fan cover. If the front half ventral fins are glued to the fuselage, the fan cover will not be removable to access the ducted fan unit.

3. Insert the ventral fins into the fan cover as shown in the diagram to the right. Verify the ventral fins are angled outward as shown below.
4. Press the ventral fins into position and wipe off any excess glue with a paper towel.
5. With the model upside down, secure the ventral fins in position until the glue cures.

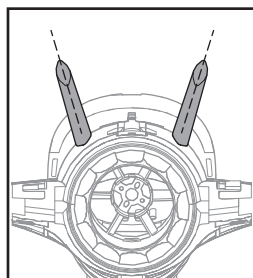

Verify the ventral fins are angled outward.

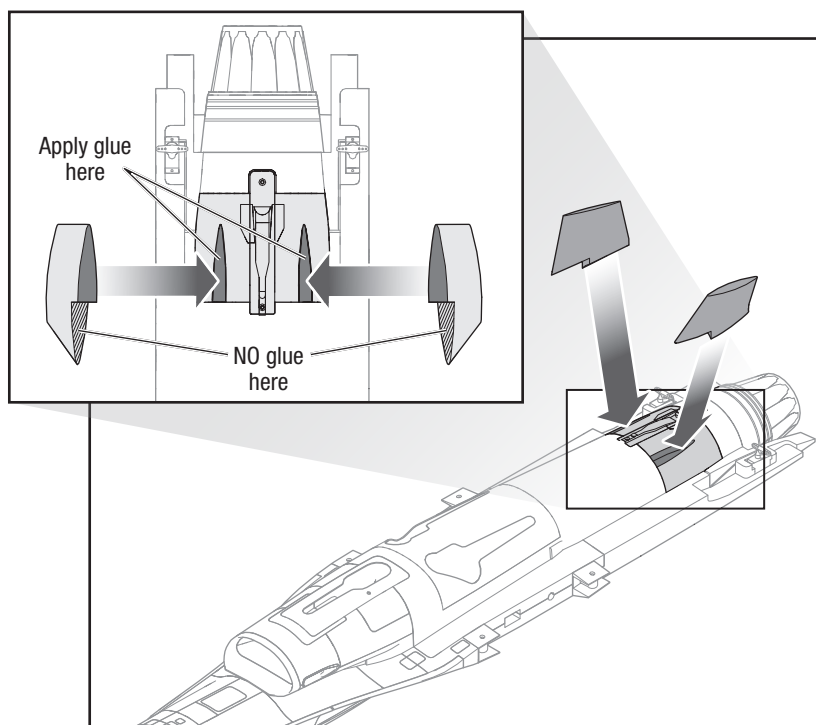

Horizontal Stabilizer Installation

1. Wipe the mating surfaces on the horizontal stabilizers and fuselage with a paper towel dampened with alcohol to remove any dust or loose paint before applying glue.
2. Using medium CA glue, apply a thin layer to the horizontal stabilizer mounting surfaces of the fuselage, shaded dark gray in the illustration.
3. Attach the horizontal stabilizers to the fuselage as shown.
4. Press the horizontal stabilizers into position and wipe off any excess glue with a paper towel.
5. With the model inverted, hold the stabilizers in position while the glue cures.

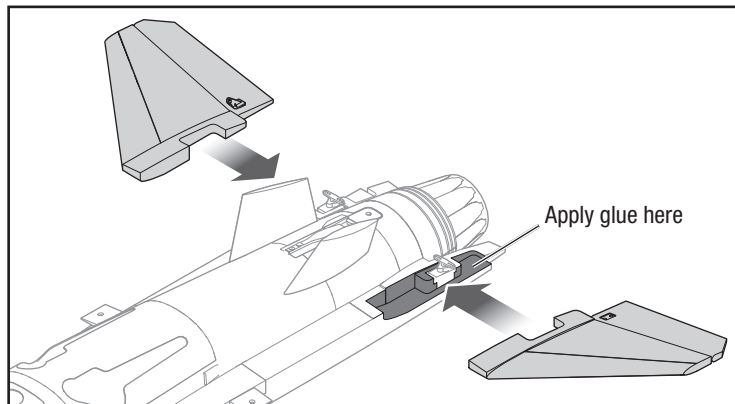

Vertical Stabilizer Installation

1. Connect the rudder servo to the servo extension tucked in the cavity. Verify the servo is operating correctly with your radio system before proceeding.
2. Wipe the mating surfaces of the vertical stabilizer and fuselage with a paper towel dampened with alcohol to remove any dust or loose paint.
3. Tuck the rudder servo lead and connector into the fuselage cavity .
4. Apply a thin layer of medium CA glue in the vertical stabilizer mounting cavity of the fuselage, as indicated by the dark shading in the illustration.
5. Attach the vertical stabilizer to the fuselage as shown.
6. Press the vertical stabilizer into position. Wipe off any excess glue with a paper towel.
7. With the model sitting upright and level, ensure the vertical stabilizer is kept accurately aligned while the glue cures.

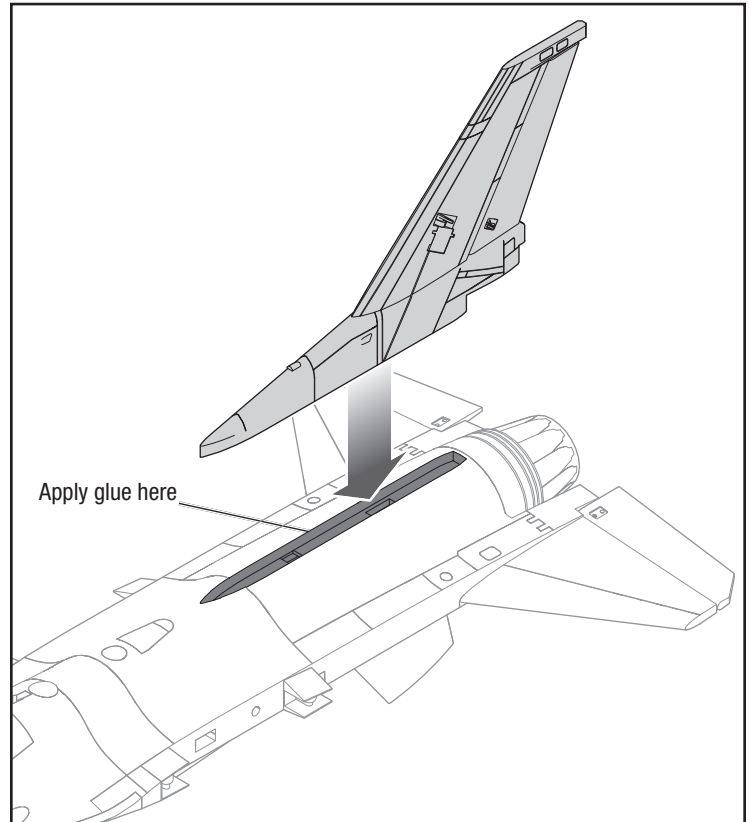
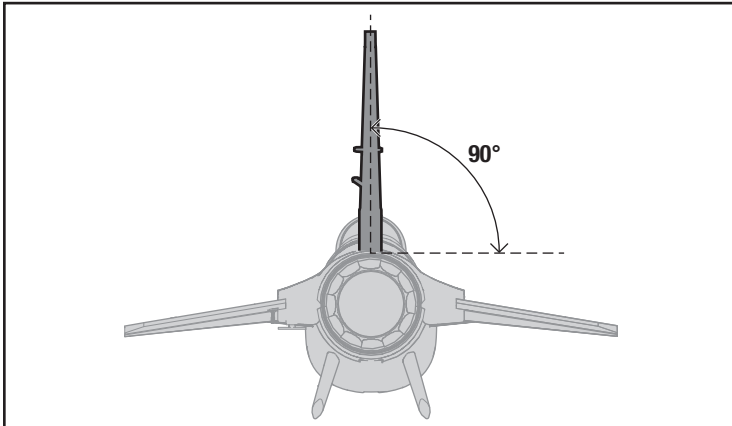

Nose Cone Installation

Slide the nose cone into place as shown. The nose cone is held in place magnetically.

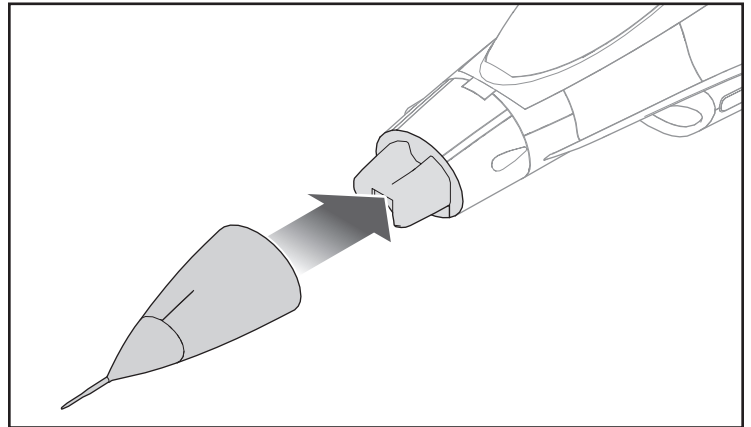

Wing Installation

1. Slide the wing tube into the fuselage.
2. Slide the wings onto the wing tube.
3. Secure the wing halves in position from the bottom using the four included 3 x 16mm screws and a #2 Phillips screwdriver.

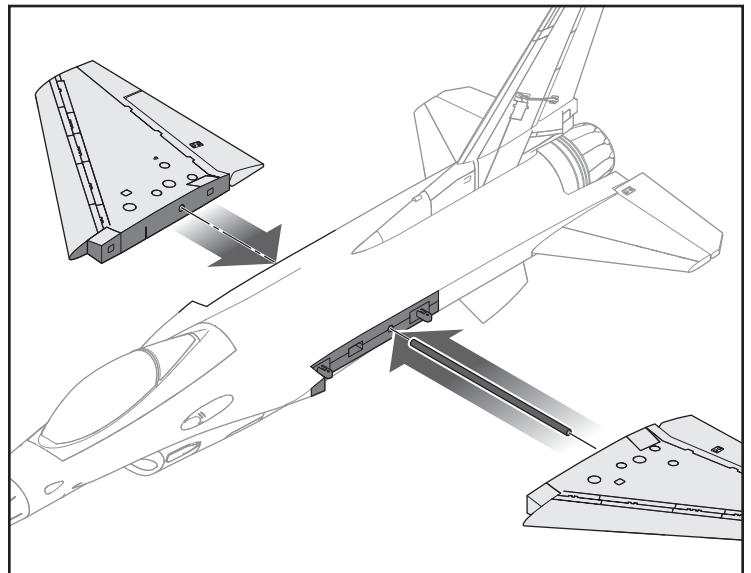
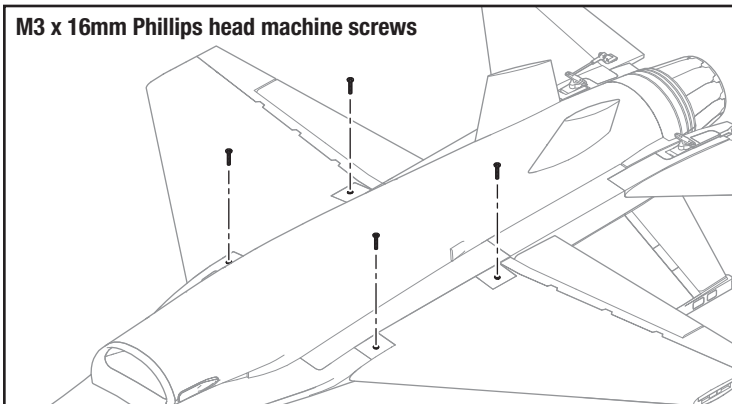

Scale Accessories *Optional*

The wingtip missiles may be installed for flight or removed as desired.

1. Insert the missile mounting tabs into the wingtip mounting bracket.
 2. Slide the missile backward to lock the tab in place.
- Disassemble in reverse order.

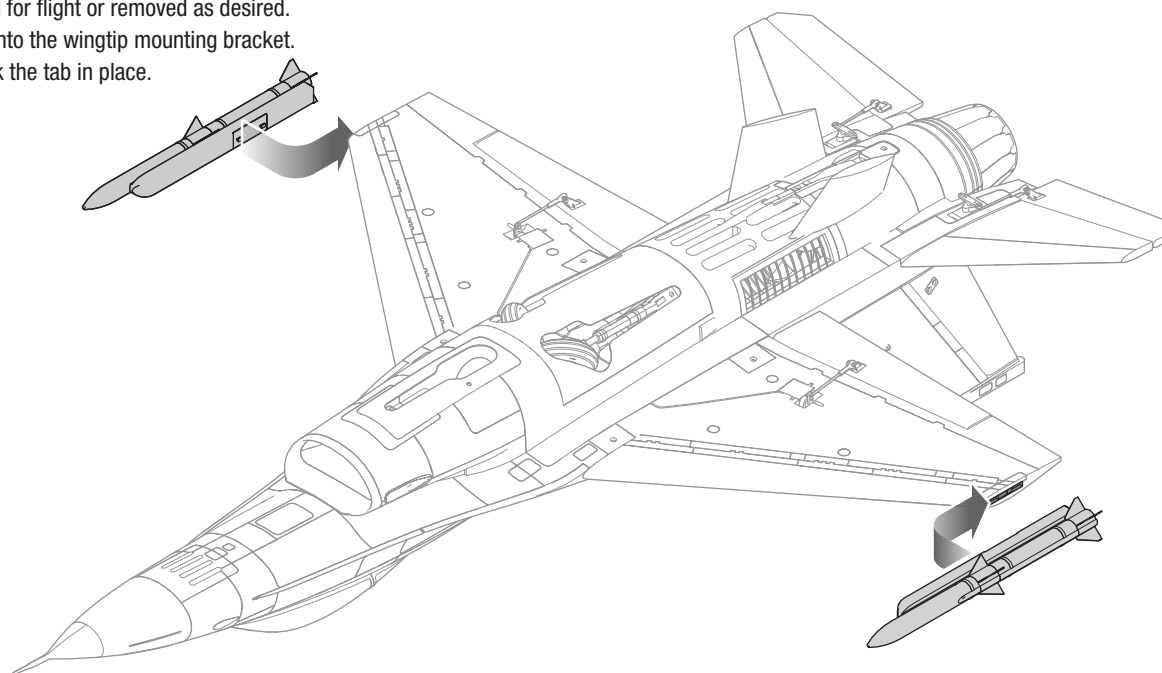

Battery Installation and ESC Arming

Battery Selection

The Spektrum™ 3200mAh 22.2V 6S 30C Li-Po battery (SPMX32006S30) is recommended. Refer to the Optional Parts List for other recommended batteries. If using a battery other than those listed, the battery should be within the range of capacity, dimensions and weight of the Spektrum Li-Po battery packs to fit in the fuselage. Be sure the model balances at the recommended center of gravity (CG) before flying.

1. Lower the throttle to the lowest setting.
2. Power on the transmitter, and wait 5 seconds.
3. Slide the hatch latch rearward and lift the hatch out of the fuselage.
4. Apply the loop side of hook and loop tape to the bottom of your battery. Apply the hook side inside the battery compartment.
5. Install the fully charged battery in the middle of the battery compartment.
6. Secure the battery using the installed hook and loop strap.
7. Connect the battery to the ESC. The ESC is now armed. Keep the aircraft immobile and away from wind upright and on flat surface, or the system will not initialize. When the model initializes the motor will produce a single tone followed immediately by three or four tones, indicating the cell count of the connected battery. The LED on the receiver illuminates.
8. Reinstall the battery hatch, ensuring the latch fully seats.

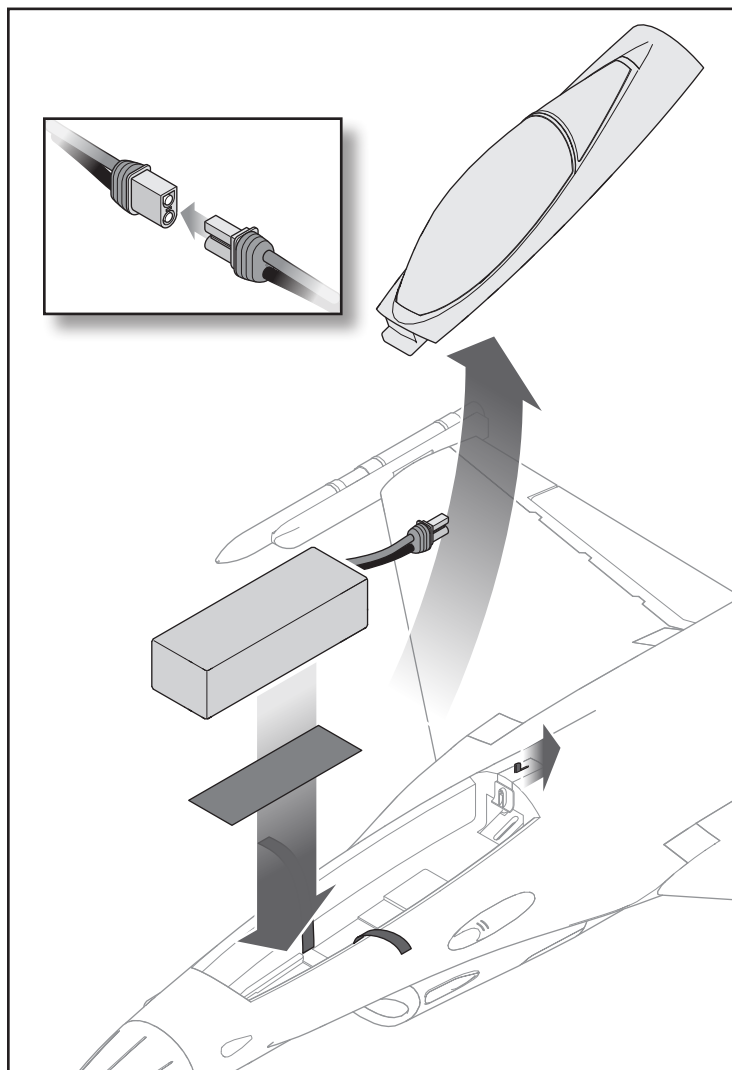

General Binding Tips and Failsafe

- The included receiver has been specifically programmed for operation of this aircraft. Refer to the receiver manual for correct setup if the receiver is replaced.
- Keep away from large metal objects while binding.
- Do not point the transmitter's antenna directly at the receiver while binding.
- The red LED on the receiver will flash rapidly when the receiver enters bind mode.
- Once bound, the receiver will retain its bind settings for that transmitter until you re-bind.
- If the receiver loses transmitter communication, the failsafe will activate. Failsafe moves the throttle channel to low throttle. Pitch and roll channels move to actively stabilize the aircraft in a descending turn.
- If problems occur, refer to the troubleshooting guide or if needed, contact the appropriate Horizon Product Support office.

Transmitter and Receiver Binding / Enable or Disable SAFE Select

The BNF Basic version of this airplane includes SAFE Select technology, enabling you to choose the level of flight protection. SAFE mode includes angle limits and automatic self leveling. AS3X mode provides the pilot with a direct response to the control sticks. SAFE Select is enabled or disabled during the bind process. With SAFE Select disabled the aircraft is always in AS3X mode. With SAFE Select enabled the aircraft will be in SAFE Select mode all the time, or you can assign a switch to toggle between SAFE Select and AS3X modes.

Thanks to SAFE Select technology, this aircraft can be configured for full-time SAFE mode, full-time AS3X mode, or mode selection can be assigned to a switch.

IMPORTANT: Before binding, read the transmitter setup section in this manual and complete the transmitter setup table to ensure your transmitter is properly programmed for this aircraft.

IMPORTANT: Move the transmitter flight controls (rudder, elevators, and ailerons) and the throttle trim to neutral. Move the throttle to low before and during binding. This process defines the failsafe settings.

You can use either the **bind button** on the receiver case **OR** a conventional **bind plug** to complete the binding and SAFE Select process.

SAFE can also be enabled via Forward Programming.

Using The Bind Button...

To Enable SAFE Select

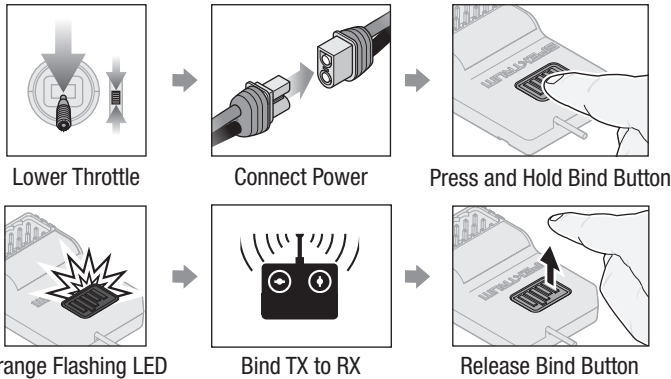

SAFE SELECT ENABLED: The control surfaces cycle back and forth **twice** with a slight pause at neutral position every time the receiver is powered on.

To Disable SAFE Select

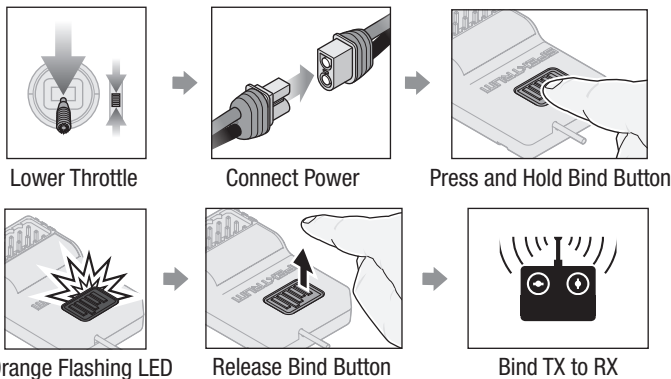

SAFE SELECT DISABLED: The control surfaces cycle back and forth **once** every time the receiver is powered on.

Using The Bind Plug...

To Enable SAFE Select

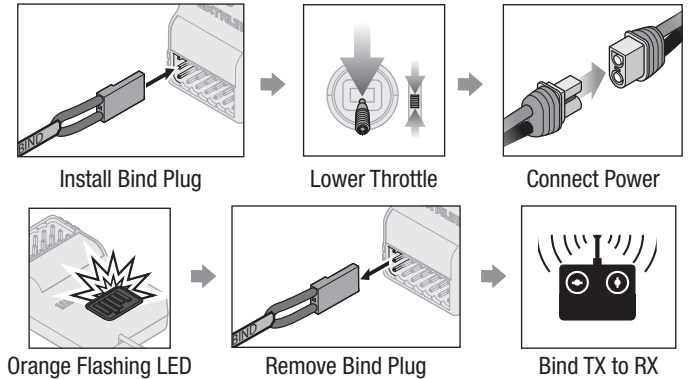

SAFE SELECT ENABLED: The control surfaces cycle back and forth **twice** with a slight pause at neutral position every time the receiver is powered on.

To Disable SAFE Select

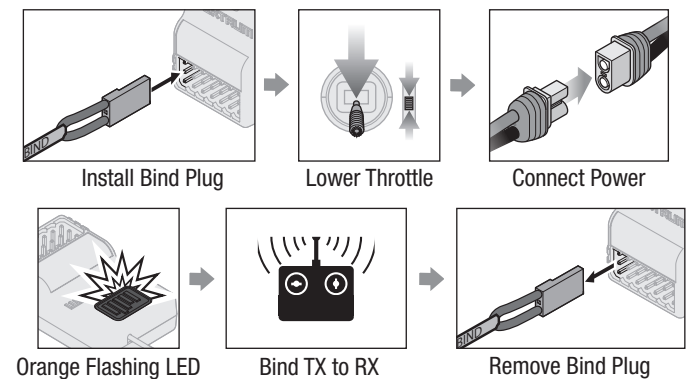

SAFE SELECT DISABLED: The control surfaces cycle back and forth **once** every time the receiver is powered on.

SAFE® Select Switch Designation

SAFE® Select technology can be easily assigned to any open switch (2 or 3 position) on your transmitter. With this feature, you have the flexibility to enable or disable the technology while in flight.

IMPORTANT: Before assigning your desired switch, ensure that the travel for that channel is set at 100% in both directions and the aileron, elevator, rudder and throttle are all on high rate with the travel at 100%. Turn throttle hold OFF if it is programmed in the transmitter.

CAUTION: Keep all body parts well clear of the rotor, intakes and exhaust tube and keep the aircraft securely restrained in case of accidental throttle activation.

Assigning a switch

1. Bind the aircraft correctly to activate SAFE Select. This will allow the system to be assigned to a switch.
2. Hold both transmitter sticks to the inside bottom corners and toggle the desired switch 5 times (1 toggle = full up and down) to assign that switch. The control surfaces of the aircraft will move, indicating the switch has been selected.

Repeat the process to assign a different switch or to deactivate the current switch if desired.

TIP: SAFE Select is assignable on any unused Channels 5–9.

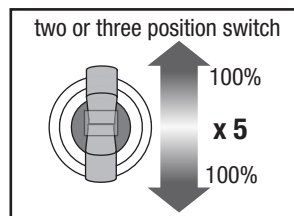
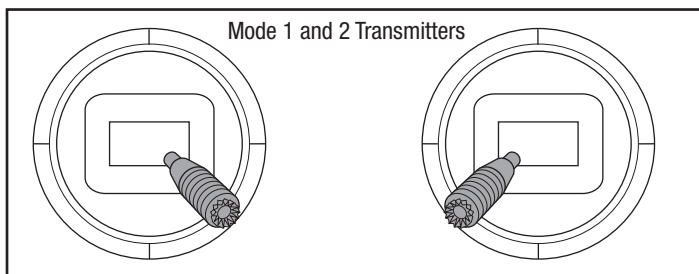

Control Horn and Servo Arm Settings

The table to the right shows the factory settings for the control horns and servo arms. Fly the aircraft at factory settings before making changes.

NOTICE: If control throws are changed from the factory settings, the AR631 gain values may need to be adjusted. Refer to the Spektrum AR631 manual for adjustment of gain values.

Linkage Installation

The elevator linkages need to be installed after the tail is glued on.

1. Insert the Z bend end of the linkage into the appropriate hole in the servo horn as shown in the table to the right
2. Connect the ball link to the control horn as shown in the table to the right.

Disassemble in reverse order.

Factory Setting	Horns	Arms
Elevator		
Rudder		
Aileron		

Control Surface Centering

During assembly the control surfaces need to be mechanically centered when the servos are at neutral.

Assemble the model, set up the transmitter, bind the transmitter to the aircraft receiver, and set the trims and sub-trims to 0. With the model powered on, make final adjustments as needed so all the flight control surfaces are centered.

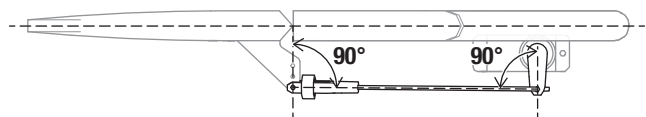

If adjustment is required:

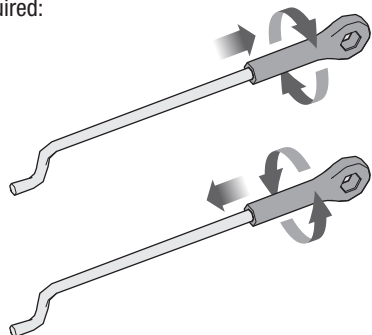

- Turn the linkage clockwise or counterclockwise to achieve the correct length so the control surface is centered.
- Attach the linkage to the control horn after adjustment.

After flying, you may choose to adjust the linkage positions for the desired control response. See the table below.

NOTICE: If control throws are changed from the factory settings, the AR631 gain values may need to be adjusted. Refer to the Spektrum AR631 manual for adjustment of gain values.

Tuning	Horns	Arms
More control throw		
Less control throw		

Center of Gravity (CG)

NOTICE: Install the battery in the aircraft, but do not arm the ESC while checking the CG. Personal injury may result.

This CG location has been determined with the recommended Li-Po battery (SPMX32006S30) installed.

The CG location is between 90-110mm, measured back from the leading edge of the wing at the fuselage, with the landing gear down.

Adjust the CG location by moving the battery pack forward or backward in the battery compartment.

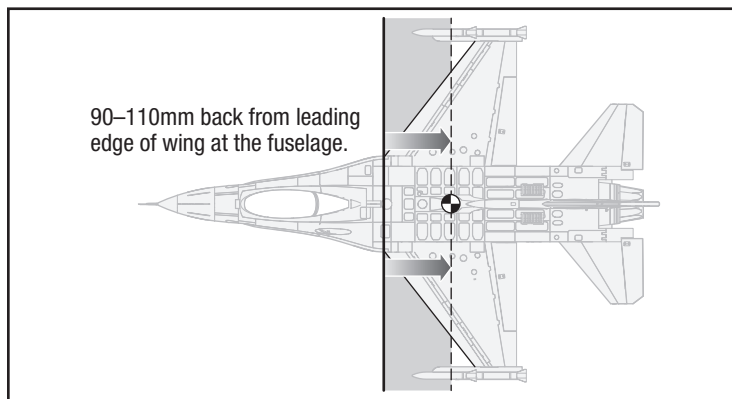

Control Direction Test

Switch on the transmitter and connect the battery. Use the transmitter to operate the aileron, elevator, rudder and flap controls. View the aircraft from the rear when checking the control directions.

Elevator

1. Pull the elevator stick back. The elevators should move up, which will cause the aircraft to pitch up.
2. Push the elevator stick forward. The elevators should move down, which will cause the aircraft to pitch down.

Ailerons

1. Move the aileron stick to the left. The left aileron should move up and the right aileron down, which will cause the aircraft to bank left.
2. Move the aileron stick to the right. The right aileron should move up and the left aileron down, which will cause the aircraft to bank right.

Rudder

1. Move the rudder stick to the left. The rudder should move to the left, which will cause the aircraft to yaw left.
2. Move the rudder stick to the right. The rudder should move to the right, which will cause the aircraft to yaw right.

	Transmitter command	Control Surface Response
Elevator		
Ailerons		
Rudder		

In Flight Trimming (BNF Basic)

During your first flight, trim the aircraft for level flight at 3/4 throttle. Make small trim adjustments with your transmitter's trim switches to straighten the aircraft's flight path.

After adjusting the trim, do not touch the control sticks for 3 seconds. This allows the receiver to learn the correct settings to optimize AS3X performance.

Failure to do so could affect flight performance.

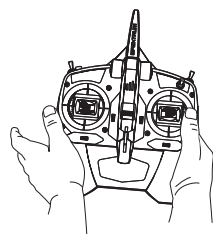

3 Seconds

Flying Tips and Repairs

Consult local laws and ordinances before choosing a flying location.

Range Check your Radio System

Before you fly, range check the radio system. Refer to your specific transmitter instruction manual for range test information.

Oscillation

Once the AS3X system is active (after advancing the throttle for the first time), you will normally see the control surfaces react to aircraft movement. In some flight conditions you may see oscillation (the aircraft rocks back and forth on one axis due to overcontrol). If oscillation occurs, refer to the Troubleshooting Guide for more information.

Takeoff

Place the aircraft facing into the wind. Set your transmitter in low rate. Gradually increase the throttle to 3/4 and steer with the rudder. As the plane reaches flying speed, pull back gently on the elevator. When airborne, climb to a comfortable altitude before retracting the landing gear.

Flying

For your first flights with the recommended battery pack (SPMX32006S30), set your transmitter timer or a stopwatch to three minutes. When the timer expires, land the aircraft. Adjust your timer for longer or shorter flights once you have flown the model. If at any time the motor power reduces, land the aircraft immediately to recharge the flight battery. See the Low Voltage Cutoff (LVC) section for more details on maximizing battery health and run time.

Landing

Land the aircraft into the wind. Use a small amount of throttle for the entire descent. Lower the throttle to 1/4 and lower the landing gear. Lowering the landing gear will help slow the aircraft for landing.

Keep the throttle on until the aircraft is ready to flare. During flare, keep the wings level and the aircraft pointed into the wind. Gently lower the throttle while pulling back on the elevator to bring the aircraft down on its wheels.

If landing on grass, it is best to hold full up elevator after touchdown and when taxiing to prevent the nose from digging in.

Once on the ground, avoid sharp turns until the plane has slowed sufficiently to prevent tipping and scraping of the wingtips.

Post Flight

1. Disconnect the flight battery from the ESC.
2. Power OFF the transmitter.
3. Remove the flight battery from the aircraft.
4. Recharge the flight battery.

NOTICE: If a crash is imminent, reduce the throttle and trim fully. Failure to do so could result in extra damage to the airframe, as well as damage to the ESC and motor.

NOTICE: After any impact, always ensure the receiver is secure in the fuselage. If you replace the receiver, install the new receiver in the same orientation as the original receiver or damage may result.

NOTICE: Crash damage is not covered under warranty.

NOTICE: When you are finished flying, never leave the aircraft in direct sunlight or in a hot, enclosed area such as a car. Doing so can damage the aircraft.

Low Voltage Cutoff (LVC)

When a Li-Po battery is discharged below 3V per cell, it will not hold a charge. The ESC protects the flight battery from over-discharge using Low Voltage Cutoff (LVC). Before the battery charge decreases too much, LVC removes power supplied to the motor. Power to the motor reduces, showing that some battery power is reserved for flight control and safe landing.

Disconnect and remove the Li-Po battery from the aircraft after use to prevent trickle discharge. Charge your Li-Po battery to about half capacity before storage. During storage, make sure the battery charge does not fall below 3V per cell. LVC does not prevent the battery from over-discharge during storage.

NOTICE: Repeated flying to LVC will damage the battery.

TIP: Monitor your aircraft battery's voltage before and after flying by using a Smart LiPo Battery Checker and Servo Driver (SPMXBC100, sold separately).

Repairs

Thanks to the EPO foam material in this aircraft, repairs to the foam can be made using virtually any adhesive (hot glue, regular CA, epoxy, etc). When parts are not repairable, see the Replacement Parts List for ordering by item number. For a listing of all replacement and optional parts, refer to the list at the end of this manual.

NOTICE: Use of CA accelerant on your aircraft can damage the paint. DO NOT handle the aircraft until accelerant fully dries.

5. Repair or replace all damaged parts.
6. Store the flight battery apart from the aircraft and monitor the battery charge.
7. Make note of the flight conditions and flight plan results, planning for future flights.

PNP Receiver Selection and Installation

The Spektrum AR631 receiver is recommended for this airplane. If you choose to install another receiver, ensure that it is at least a 6-channel full range receiver. Refer to your receiver manual for correct installation and operation instructions.

CAUTION: Incorrect installation of the receiver could cause a crash.

Installation (AR631 shown)

1. Remove the canopy from the fuselage.
2. Mount the receiver parallel to the length of the fuselage, as shown, using double-sided servo tape.

IMPORTANT: Route the antenna straight back through the fuselage tunnel.

3. Attach the appropriate control surfaces to their respective ports on the receiver using the table at the right.

AR631 Port Assignments

BND/PRG/SRXL2 = BIND

- 1 = Throttle
- 2 = Aileron
- 3 = Elevator
- 4 = Rudder
- 5 = Retracts
- 6 = NA

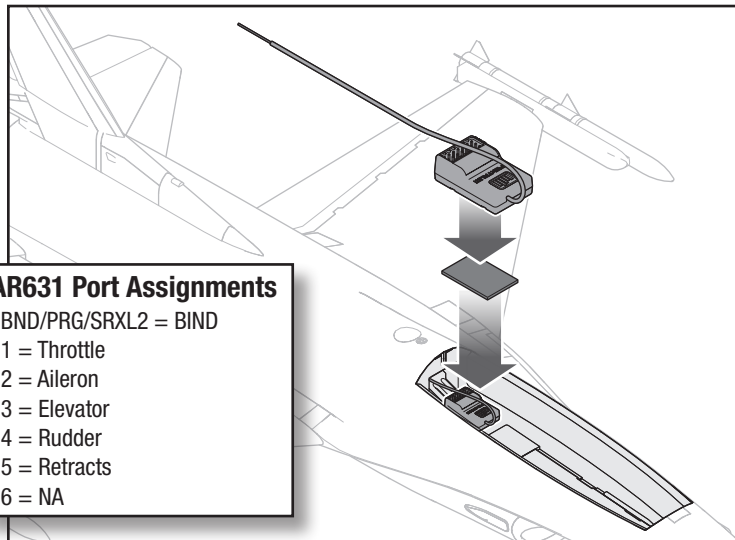

Motor Service

CAUTION: Always disconnect the flight battery before performing motor service.

Disassembly

1. Remove the two 3mm x 10mm counter-sunk machine screws holding the fan cover in place. Remove the fan cover.
2. Remove the two 3mm x 12mm counter-sunk self tapping screws holding the ducted fan housing in place.
3. Remove the 3mm x 20mm machine screw holding the spinner on the motor shaft. Remove the spinner.
4. Gently grasp the impeller and remove the hex head nut holding the fan on the motor shaft. Remove the fan.
5. Remove the fan adaptor from the motor shaft.
6. Remove the four 3mm x 6mm machine screws and the motor from the fan housing.
7. Disconnect the motor wires from the ESC wires.

Assemble in reverse order.

When re-assembling the motor and fan assembly:

- Correctly match the motor wire colors with the ESC wires.
- Ensure the fan is installed with the front facing the nose of the aircraft.
- A tool is required to tighten the nut on the rotor and collet.
- Ensure no wiring is pinched by any of the power components.
- Ensure the ESC cover is securely glued to the fuselage.
- Ensure the spinner is fully connected for safe operation.

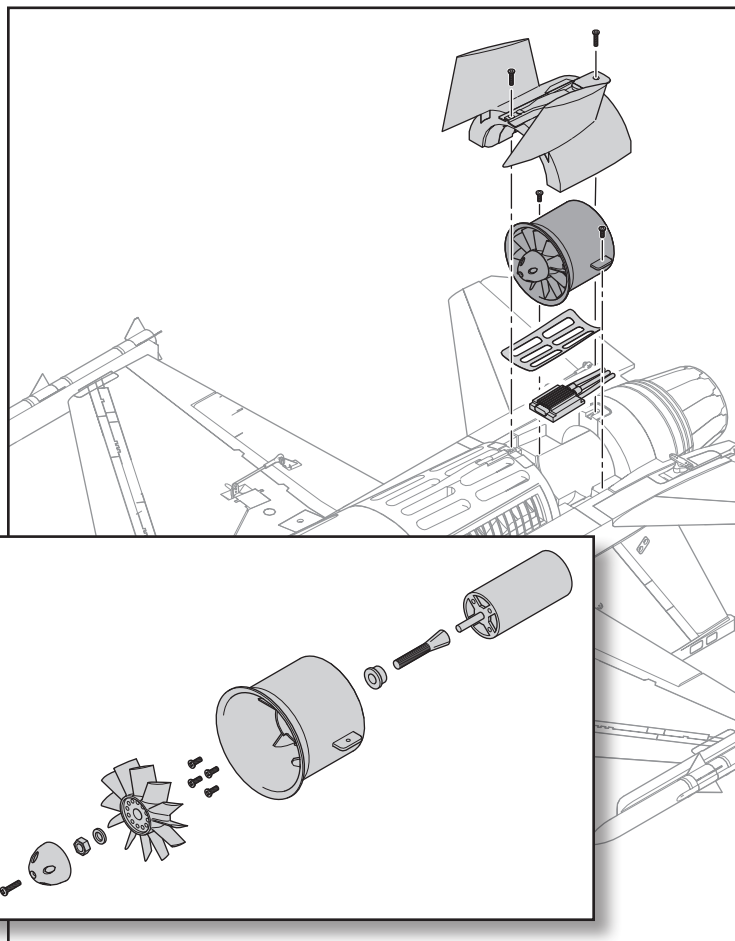

Troubleshooting Guide AS3X

Problem	Possible Cause	Solution
Oscillation	Damaged impeller, fan adaptor or fan housing	Replace damaged parts
	Imbalanced impeller	Balance the propeller
	Motor vibration	Replace parts or correctly align all parts and tighten fasteners as needed
	Loose receiver	Align and secure receiver in fuselage
	Loose aircraft controls	Tighten or otherwise secure parts (servo, arm, linkage, horn and control surface)
	Worn parts	Replace worn parts (especially propeller, spinner or servo)
	Irregular servo movement	Replace servo
Inconsistent flight performance	Trim is not at neutral	If you adjust trim more than 8 clicks, adjust the clevis to remove trim
	Sub-Trim is not at neutral	No Sub-Trim is allowed. Adjust the servo linkage
	Aircraft was not kept immobile for 5 seconds after battery connection	With the throttle stick in lowest position. Disconnect battery, then reconnect battery and keep the aircraft still for 5 seconds
Incorrect response to the AS3X Control Direction Test	Incorrect direction settings in the receiver, which can cause a crash	DO NOT fly. Correct the direction settings (refer to the receiver manual), then fly

Troubleshooting Guide

Problem	Possible Cause	Solution
Aircraft will not respond to throttle but responds to other controls	Throttle not at idle and/or throttle trim too high	Reset controls with throttle stick and throttle trim at lowest setting
	Throttle servo travel is lower than 100%	Make sure throttle servo travel is 100% or greater
	Throttle channel is reversed	Reverse throttle channel on transmitter
	Motor disconnected from ESC	Make sure motor is connected to the ESC
Extra propeller noise or extra vibration	Damaged impeller and spinner, collet or motor	Replace damaged parts
	Impeller is out of balance	Balance or replace impeller
	Fan nut is too loose	Tighten the prop nut
Reduced flight time or aircraft underpowered	Flight battery charge is low	Completely recharge flight battery
	Flight battery damaged	Replace flight battery and follow flight battery instructions
	Flight conditions may be too cold	Make sure battery is warm before use
	Battery capacity too low for flight conditions	Replace battery or use a larger capacity battery
Aircraft will not Bind (during binding) to transmitter	Transmitter too near aircraft during binding process	Move powered transmitter a few feet from aircraft, disconnect and reconnect flight battery to aircraft
	Aircraft or transmitter is too close to large metal object, wireless source or another transmitter	Move aircraft and transmitter to another location and attempt binding again
	The bind plug is not installed correctly in the bind port	Install bind plug in bind port and bind the aircraft to the transmitter
	Flight battery/transmitter battery charge is too low	Replace/recharge batteries
	Bind switch or button not held long enough during bind process	Power off transmitter and repeat bind process. Hold transmitter bind button or switch until receiver is bound
Aircraft will not connect (after binding) to transmitter	Transmitter too near aircraft during connecting process	Move powered transmitter a few feet from aircraft, disconnect and reconnect flight battery to aircraft
	Aircraft or transmitter is too close to large metal object, wireless source or another transmitter	Move aircraft and transmitter to another location and attempt connecting again
	Bind plug left installed in bind port	Rebind transmitter to the aircraft and remove the bind plug before cycling power
	Aircraft bound to different model memory (ModelMatch™ radios only)	Select correct model memory on transmitter
	Flight battery/Transmitter battery charge is too low	Replace/recharge batteries
	Transmitter may have been bound to a different aircraft using different DSM protocol	Bind aircraft to transmitter
Control surface does not move	Control surface, control horn, linkage or servo damage	Replace or repair damaged parts and adjust controls
	Wire damaged or connections loose	Do a check of wires and connections, connect or replace as needed
	Transmitter is not bound correctly or the incorrect airplanes was selected	Re-bind or select correct airplanes in transmitter
	Flight battery charge is low	Fully recharge flight battery
	BEC (Battery Elimination Circuit) of the ESC is damaged	Replace ESC
Controls reversed	Transmitter settings are reversed	Perform the Control Direction Test and adjust the controls on transmitter appropriately
Motor power pulses then motor loses power	ESC uses default soft Low Voltage Cutoff (LVC)	Recharge flight battery or replace battery that is no longer performing
	Weather conditions might be too cold	Postpone flight until weather is warmer
	Battery is old, worn out, or damaged	Replace battery
	Battery C rating might be too small	Use recommended battery

Replacement Parts

Part #	Description
EFL7801	Fuselage: F-16 Thunderbird 70mm EDF
EFL7802	Wing Set: F-16 Thunderbird 70mm EDF
EFL7803	Vertical Stabilizer: F-16 Thunderbird 70mm EDF
EFL7804	Horizontal Stabilizers: F-16 Thunderbird 70mm EDF
EFL7805	Wing Tip Missile-1: F-16 Thunderbird 70mm EDF
EFL7807	Cockpit/Hatch: F-16 Thunderbird 70mm EDF
EFL7808	Nose Cone: F-16 Thunderbird 70mm EDF
EFL7809	Ventral Fin Set: F-16 Thunderbird 70mm EDF
EFL7811	Nose Landing Gear Set: F-16 Thunderbird 70mm EDF
EFL7812	Main Landing Gear Set: F-16 Thunderbird 70mm EDF
EFL7814	Nose Gear System: F-16 Thunderbird 70mm EDF
EFL7815	Main Gear System: F-16 Thunderbird 70mm EDF
EFL7816	Landing Gear Covers: F-16 Thunderbird 70mm EDF
EFL7817	Linkage Rod Set: F-16 Thunderbird 70mm EDF
EFL7818	Wing Tube: F-16 Thunderbird 70mm EDF
EFL7819	Screw Set: F-16 Thunderbird 70mm EDF
EFL7820	Wheel Set: F-16 Thunderbird 70mm EDF
EFL7821	Decal Set: F-16 Thunderbird 70mm EDF
EFL7822	Retract Strut Pins: F-16 70mm EDF
SPMXAE85C	Avian 85-Amp Smart Lite Brushless ESC, 3S-6S IC5
EFLA7012DF	70mm Ducted Fan
EFLG325	Nose Gear E-Retract: F-16 70mm EDF
EFLG326	Main Gear E-Retract: F-16 70mm EDF

Part #	Description
SPMXAM3000	Brushless Inrunner Motor; 3060-KV1900 4-pole
SPMSA335	A335 9g Digital Servo Metal Gear
SPMSA335R	A335R 9g Digital Servo Metal Gear Reverse
SPMAR631	AR631 6 Channel AS3X & SAFE Receiver

Recommended Equipment

Part #	Description
SPMX32006S30	3200mAh 6S 22.2V Smart 30C; IC5
SPMXCA507	Adapter: IC3 Battery/IC5 Device
SPMR6775	NX6 6 Channel Transmitter Only
SPMXC2080	S1100 G2 1x100W AC Smart Charger

Optional Accessories

Part #	Description
SPMR8200	NX8 8 Channel Transmitter Only
SPMXC2000	S2100 G2 2x100W AC Smart Charger
SPMX32006S50	3200mAh 6S 22.2V Smart 50C; IC5
SPMX40006S50	4000mAh 6S 22.2V Smart 50C; IC5
SPMX40006S30	4000mAh 6S 22.2V Smart 30C; IC5
DYN1405	LiPo Charge Protection Bag, Large
SPM6722	Spektrum Single Aircraft TX Case

Important Federal Aviation Administration (FAA) Information

Use the QR code below to learn more about the Recreational UAS Safety Test (TRUST), as was introduced by the 2018 FAA Reauthorization Bill. This free test is required by the FAA for all recreational flyers in the United States. The completed certificate must be presented upon request by any FAA or law enforcement official.



Recreational UAS Safety Test

If your model aircraft weighs more than .55lbs or 250 grams, you are required by the FAA to register as a recreational flyer and apply your registration number to the outside of your aircraft. To learn more about registering with the FAA, use the QR code below.



FAA DroneZone

AMA National Model Aircraft Safety Code

Effective January 1, 2018

A model aircraft is a non-human-carrying device capable of sustained flight within visual line of sight of the pilot or spotter(s). It may not exceed limitations of this code and is intended exclusively for sport, recreation, education and/or competition. All model flights must be conducted in accordance with this safety code and related AMA guidelines, any additional rules specific to the flying site, as well as all applicable laws and regulations.

As an AMA member I agree:

- I will not fly a model aircraft in a careless or reckless manner.
- I will not interfere with and will yield the right of way to all human-carrying aircraft using AMA's See and Avoid Guidance and a spotter when appropriate.
- I will not operate any model aircraft while I am under the influence of alcohol or any drug that could adversely affect my ability to safely control the model.
- I will avoid flying directly over unprotected people, moving vehicles, and occupied structures.
- I will fly Free Flight (FF) and Control Line (CL) models in compliance with AMA's safety programming.
- I will maintain visual contact of an RC model aircraft without enhancement other than corrective lenses prescribed to me. When using an advanced flight system, such as an autopilot, or flying First-Person View (FPV), I will comply with AMA's Advanced Flight System programming.
- I will only fly models weighing more than 55 pounds, including fuel, if certified through AMA's Large Model Airplane Program.
- I will only fly a turbine-powered model aircraft in compliance with AMA's Gas Turbine Program.
- I will not fly a powered model outdoors closer than 25 feet to any individual, except for myself or my helper(s) located at the flightline, unless I am taking off and landing, or as otherwise provided in AMA's Competition Regulation.
- I will use an established safety line to separate all model aircraft operations from spectators and bystanders.

Limited Warranty

What this Warranty Covers

Horizon Hobby, LLC, (Horizon) warrants to the original purchaser that the product purchased (the "Product") will be free from defects in materials and workmanship at the date of purchase.

What is Not Covered

This warranty is not transferable and does not cover (i) cosmetic damage, (ii) damage due to acts of God, accident, misuse, abuse, negligence, commercial use, or due to improper use, installation, operation or maintenance, (iii) modification of or to any part of the Product, (iv) attempted service by anyone other than a Horizon Hobby authorized service center, (v) Product not purchased from an authorized Horizon dealer, or (vi) Product not compliant with applicable technical regulations, or (vii) use that violates any applicable laws, rules, or regulations.

OTHER THAN THE EXPRESS WARRANTY ABOVE, HORIZON MAKES NO OTHER WARRANTY OR REPRESENTATION, AND HEREBY DISCLAIMS ANY AND ALL IMPLIED WARRANTIES, INCLUDING, WITHOUT LIMITATION, THE IMPLIED WARRANTIES OF NON-INFRINGEMENT, MERCHANTABILITY AND FITNESS FOR A PARTICULAR PURPOSE. THE PURCHASER ACKNOWLEDGES THAT THEY ALONE HAVE DETERMINED THAT THE PRODUCT WILL SUITABLY MEET THE REQUIREMENTS OF THE PURCHASER'S INTENDED USE.

Purchaser's Remedy

Horizon's sole obligation and purchaser's sole and exclusive remedy shall be that Horizon will, at its option, either (i) service, or (ii) replace, any Product determined by Horizon to be defective. Horizon reserves the right to inspect any and all Product(s) involved in a warranty claim. Service or replacement decisions are at the sole discretion of Horizon. Proof of purchase is required for all warranty claims. SERVICE OR REPLACEMENT AS PROVIDED UNDER THIS WARRANTY IS THE PURCHASER'S SOLE AND EXCLUSIVE REMEDY.

Limitation of Liability

HORIZON SHALL NOT BE LIABLE FOR SPECIAL, INDIRECT, INCIDENTAL OR CONSEQUENTIAL DAMAGES, LOSS OF PROFITS OR PRODUCTION OR COMMERCIAL LOSS IN ANY WAY, REGARDLESS OF WHETHER SUCH CLAIM IS BASED IN CONTRACT, WARRANTY, TORT, NEGLIGENCE, STRICT LIABILITY OR ANY OTHER THEORY OF LIABILITY, EVEN IF HORIZON HAS BEEN ADVISED OF THE POSSIBILITY OF SUCH DAMAGES. Further, in no event shall the liability of Horizon exceed the individual price of the Product on which liability is asserted. As Horizon has no control over use, setup, final assembly, modification or misuse, no liability shall be assumed nor accepted for any resulting damage or injury. By the act of use, setup or assembly, the user accepts all resulting liability. If you as the purchaser or user are not prepared to accept the liability associated with the use of the Product, purchaser is advised to return the Product immediately in new and unused condition to the place of purchase.

Law

These terms are governed by Illinois law (without regard to conflict of law principals). This warranty gives you specific legal rights, and you may also have other rights which vary from state to state. Horizon reserves the right to change or modify this warranty at any time without notice.

WARRANTY SERVICES

Questions, Assistance, and Services

Your local hobby store and/or place of purchase cannot provide warranty support or service. Once assembly, setup or use of the Product has been started, you must contact your local distributor or Horizon directly. This will enable Horizon

to better answer your questions and service you in the event that you may need any assistance. For questions or assistance, please visit our website at www.horizonhobby.com, submit a Product Support Inquiry, or call the toll free telephone number referenced in the Warranty and Service Contact Information section to speak with a Product Support representative.

Inspection or Services

If this Product needs to be inspected or serviced and is compliant in the country you live and use the Product in, please use the Horizon Online Service Request submission process found on our website or call Horizon to obtain a Return Merchandise Authorization (RMA) number. Pack the Product securely using a shipping carton. Please note that original boxes may be included, but are not designed to withstand the rigors of shipping without additional protection. Ship via a carrier that provides tracking and insurance for lost or damaged parcels, as Horizon is not responsible for merchandise until it arrives and is accepted at our facility. An Online Service Request is available at http://www.horizonhobby.com/content/service-center_render-service-center. If you do not have internet access, please contact Horizon Product Support to obtain a RMA number along with instructions for submitting your product for service. When calling Horizon, you will be asked to provide your complete name, street address, email address and phone number where you can be reached during business hours. When sending product into Horizon, please include your RMA number, a list of the included items, and a brief summary of the problem. A copy of your original sales receipt must be included for warranty consideration. Be sure your name, address, and RMA number are clearly written on the outside of the shipping carton.

NOTICE: Do not ship LiPo batteries to Horizon. If you have any issue with a LiPo battery, please contact the appropriate Horizon Product Support office.

Warranty Requirements

For Warranty consideration, you must include your original sales receipt verifying the proof-of-purchase date. Provided warranty conditions have been met, your Product will be serviced or replaced free of charge. Service or replacement decisions are at the sole discretion of Horizon.

Non-Warranty Service

Should your service not be covered by warranty, service will be completed and payment will be required without notification or estimate of the expense unless the expense exceeds 50% of the retail purchase cost. By submitting the item for service you are agreeing to payment of the service without notification. Service estimates are available upon request. You must include this request with your item submitted for service. Non-warranty service estimates will be billed a minimum of ½ hour of labor. In addition you will be billed for return freight. Horizon accepts money orders and cashier's checks, as well as Visa, MasterCard, American Express, and Discover cards. By submitting any item to Horizon for service, you are agreeing to Horizon's Terms and Conditions found on our website http://www.horizonhobby.com/content/service-center_render-service-center.

ATTENTION: Horizon service is limited to Product compliant in the country of use and ownership. If received, a non-compliant Product will not be serviced. Further, the sender will be responsible for arranging return shipment of the un-serviced Product, through a carrier of the sender's choice and at the sender's expense. Horizon will hold non-compliant Product for a period of 60 days from notification, after which it will be discarded.

10/15

Contact Information

Country of Purchase	Horizon Hobby	Contact Information	Address
United States of America	Horizon Service Center (Repairs and Repair Requests)	servicecenter.horizonhobby.com/RequestForm/	2904 Research Road Champaign, Illinois, 61822 USA
	Horizon Product Support (Product Technical Assistance)	productsupport@horizonhobby.com 877-504-0233	
	Sales	websales@horizonhobby.com 800-338-4639	
European Union	Horizon Technischer Service	service@horizonhobby.eu	Hanskampring 9 D 22885 Barsbüttel, Germany
	Sales: Horizon Hobby GmbH	+49 (0) 4121 2655 100	

FCC Information

FCC ID: BRWSPMSR6200A

This equipment complies with FCC and IC radiation exposure limits set forth for an uncontrolled environment. This equipment should be installed and operated with minimum distance 20cm between the radiator and/or antenna and your body (excluding fingers, hands, wrists, ankles and feet). This transmitter must not be co-located or operating in conjunction with any other antenna or transmitter.

Supplier's Declaration of Conformity

FC F-16 Thunderbirds 70mm EDF BNF Basic (EFL178500):

This device complies with part 15 of the FCC Rules. Operation is subject to the following two conditions: (1) This device may not cause harmful interference, and (2) this device must accept any interference received, including interference that may cause undesired operation.



CAUTION: Changes or modifications not expressly approved by the party responsible for compliance could void the user's authority to operate the equipment.

NOTE: This equipment has been tested and found to comply with the limits for a Class B digital device, pursuant to part 15 of the FCC Rules. These limits are designed to provide reasonable protection against harmful interference in a

residential installation. This equipment generates, uses and can radiate radio frequency energy and, if not installed and used in accordance with the instructions, may cause harmful interference to radio communications. However, there is no guarantee that interference will not occur in a particular installation. If this equipment does cause harmful interference to radio or television reception, which can be determined by turning the equipment off and on, the user is encouraged to try to correct the interference by one or more of the following measures:

- Reorient or relocate the receiving antenna.
- Increase the separation between the equipment and receiver.
- Connect the equipment into an outlet on a circuit different from that to which the receiver is connected.
- Consult the dealer or an experienced radio/TV technician for help.

Horizon Hobby, LLC
2904 Research Rd.,
Champaign, IL 61822
Email: compliance@horizonhobby.com
Web: HorizonHobby.com

IC Information

CAN ICES-3 (B)/NMB-3(B)

IC: 6157A-SPMSR6200A

This device contains license-exempt transmitter(s)/receiver(s) that comply with Innovation, Science, and Economic Development Canada's license-exempt RSS(s). Operation is subject to the following 2 conditions:

1. This device may not cause interference.
2. This device must accept any interference, including interference that may cause undesired operation of the device.

Compliance Information for the European Union



EU Compliance Statement:

F-16 Thunderbirds 70mm EDF BNF Basic (EFL178500): Hereby, Horizon Hobby, LLC declares that the device is in compliance with the following: EU Radio Equipment Directive 2014/53/EU; RoHS 2 Directive 2011/65/EU, RoHS 3 Directive - Amending 2011/65/EU Annex II 2015/863.

F-16 Thunderbirds 70mm EDF PNP (EFL013575): Hereby, Horizon Hobby, LLC declares that the device is in compliance with the following: EU EMC Directive 2014/30/EU; RoHS 2 Directive 2011/65/EU, RoHS 3 Directive - Amending 2011/65/EU Annex II 2015/863.

The full text of the EU declaration of conformity is available at the following internet address: <https://www.horizonhobby.com/content/support-render-compliance>.

Wireless frequency and output:

Receiver:
2404-2476MHz
5.58dBm

EU Manufacturer of Record:

Horizon Hobby, LLC
2904 Research Road
Champaign, IL 61822 USA

EU Importer of Record:

Horizon Hobby, GmbH
Hanskampring 9
22885 Barsbüttel Germany

WEEE NOTICE:



This appliance is labeled in accordance with European Directive 2012/19/EU concerning waste of electrical and electronic equipment (WEEE). This label indicates that this product should not be disposed of with household waste. It should be deposited at an appropriate facility to enable recovery and recycling.





©2023 Horizon Hobby, LLC.

E-flite, Plug-N-Play, Bind-N-Fly, BNF, the BNF logo, DSM, DSM2, DSMX, Spektrum AirWare, IC3, IC5, AS3X, SAFE, the SAFE logo, ModelMatch, and the Horizon Hobby logo are trademarks or registered trademarks of Horizon Hobby, LLC.

The Spektrum trademark is used with permission of Bachmann Industries, Inc. All other trademarks, service marks and logos are property of their respective owners.
US 8,672,726 US 9,056,667 US 9,753,457. US 10,078,329. US 9,930,567. US 10,419,970. Other patents pending.

<http://www.horizonhobby.com/>