

FreeWing M^oDEL

FreeWing 64mm EDF JET

F9F Panther User Manual

Wingspan:690mm

Length:740mm

Empty Weight:480G[w/o Battery]



MADE IN CHINA



EN 1~11

中 12~22

- 1 Note
- 2 Product basic information
- 2 Package list
- PNP Assembly instructions
- 3 Install main wing
- 4 Install horizontal stabilizer
- 4 Install vertical stabilizer
- 5 Install vertical stabilizer
- 5 Install battery
- 5 Pushrod instructions
- 5 Important additional notes
- 6 Center of gravity
- PNP Parameter setting
- 7 Control direction test
- 8 Dual rates
- 8 Remote control EXP setting suggestion
- Pre-installed component overview
- 9 Servo direction
- 9 Motor specification
- 10 Install nose landing gear
- 11 Install rear landing gear

- 12 重要提示
- 13 产品规格参数
- 13 包装列表
- PNP组装步骤介绍
- 14 主翼组装
- 15 平尾组装
- 15 垂尾组装
- 16 垂尾组装
- 16 电池介绍
- 16 舵面控制钢丝尺寸及安装孔位
- 16 重要附加说明
- 17 重心示意图
- PNP调试介绍
- 18 模型舵面测试
- 19 舵量范围
- 19 遥控器EXP设置建议
- 预装电子配件介绍
- 20 舵机介绍
- 20 电机介绍
- 21 前起落架组装
- 22 后起落架组装

- 1.This is not a toy! Operater should have a certain experience, beginners should operate under the guidance of professional players.
- 2.Before install, please read through the instructions carefully and operate strictly under instructions.
- 3.Cause of wrong operation,Freeewing and its vendors will not be held responsible for any losses.
- 4.Model planes' players must be on the age of 14 years old.
- 5.This plane used the EPO material with surface spray paint, don' t use chemical to clean, otherwise it will damage.
- 6.You should be careful to avoid flying in areas such as public places,high-voltage-intensive areas,near the highway, near the airport or any other place where laws and regulation clearly prohibit.
- 7.You cannot fly in bad weather conditions such as thunderstorms,snows....
- 8.Model plane's battery, don't allowed to put in everywhere. Storage must ensure that there is no inflammable and explosive materials in the round of 2M range.
- 9.Damaged or scrap battery should be properly recycled, it can't discard to avoid spontaneous combustion and fire.
- 10.In flying field, the waste after flying should be properly handled,it can't be abandoned or burned.
- 11.In any case, you must ensure that the throttle is in the low position and transmitter switch on, then it can connect the lipo-battery in aircraft.
- 12.Do not try to take planes by hand when flying or slow landing process. You must wait for landing stop, then carry it.

 **NOTE:** This is not a toy. Not for children under 14 years. Young people under the age of 14 should only be permitted to operate this model under the instruction and supervision of an adult. Please keep these instructions for further reference after completing model assembly.

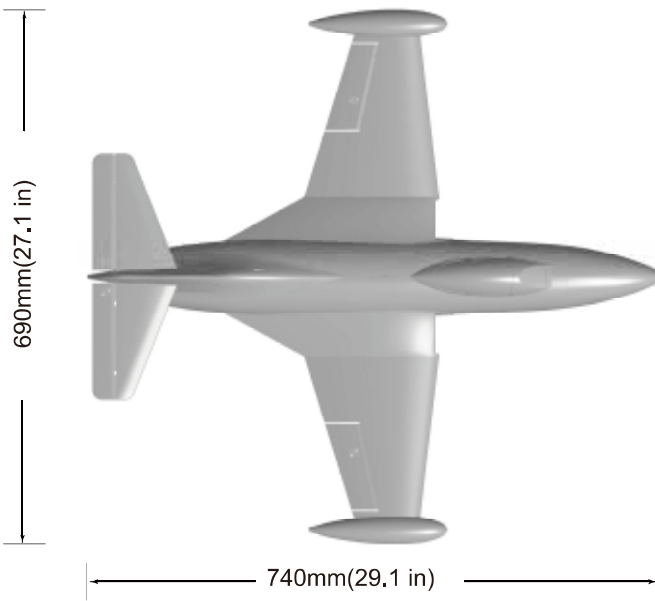

Standard Version

- Wingload: 87.8 g/dm²
- Wing Area: 8 dm²
- Motor: 2840-2850KV O/R Motor
- Servo: 9g Digital plastic servo × 3
- ESC: 40A (V2 with Thrust Reverse Fuction)
- Ducted fan: 64mm 12-blade fan
- Weight: 480g(w/o Battery)
- Li-Po Battery: 4S 1600-2200mAh
- Landing gear: No

⚠ Note: The parameters in here are derived from test result using our accessories. If use other accessories, the test result will be different. Any problem since of using other accessories, we are not able to provide technical support.

Package List

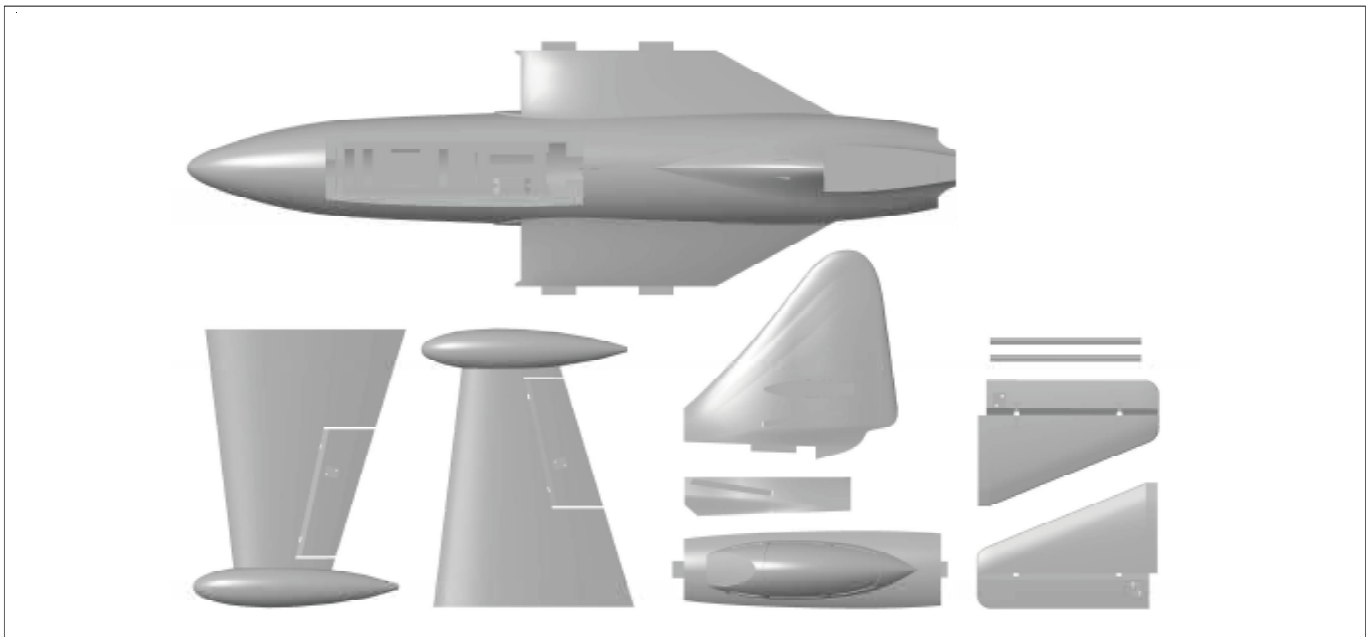

Different equipment include different spareparts. Please refer to the following contents to check your sparepart list.

No.	Name	PNP	ARF Plus
1	Fuselage	Pre-installed all electronic parts	Pre-installed servo
2	Main wing	Pre-installed all electronic parts	Pre-installed servo
3	Horizontal tail		
4	Vertical tail		

No.	Name	PNP	ARF Plus
5	Pushrod	✓	✓
6	Glue	✓	✓
7	Manual	✓	✓

Install Main Wing

As the photo show:

1. Apply gule to fix the carbon tube on the left/right wing.

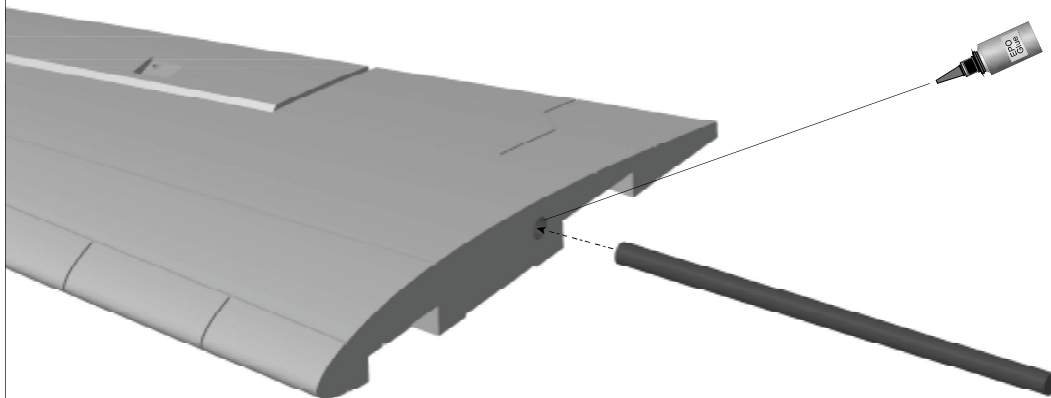

2. Apply glue to fix the main wing on the fuselage.

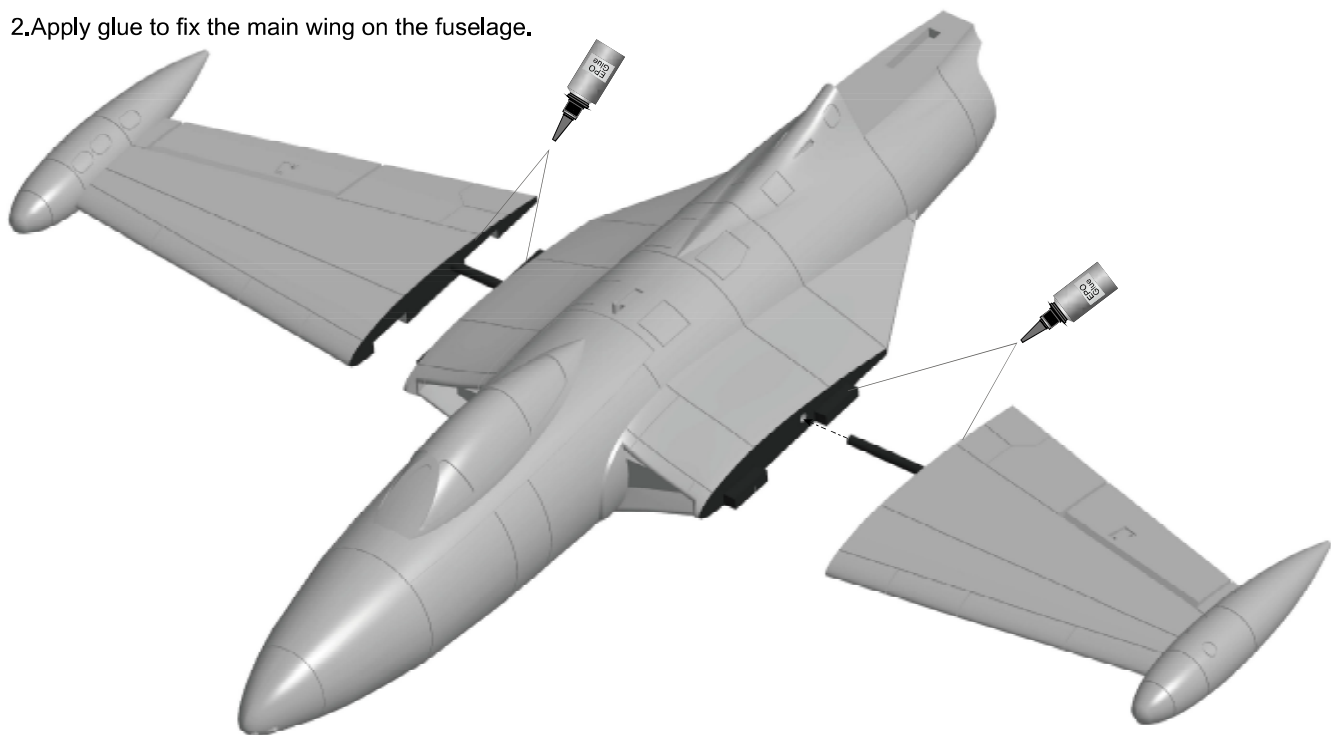

3. Penetrate the aileron servo cable through this hole into the battery compartment.

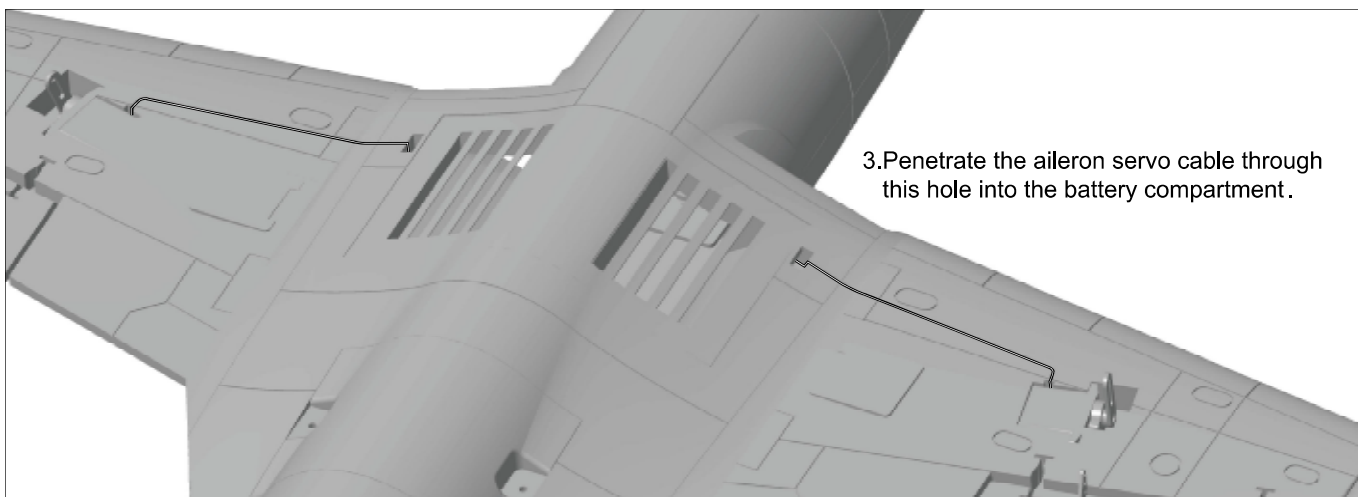

Install Horizontal Stabilizer

As the photo show:

1. Apply glue to fix the horizontal stabilizer on the vertical stabilizer.

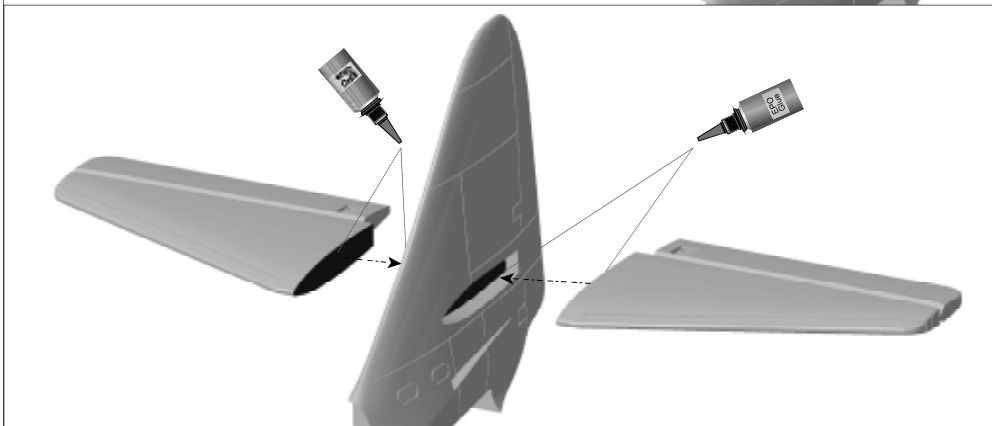

Install Vertical Stabilizer

As the photo show:

1. Apply glue to fix the horizontal stabilizer, vertical stabilizer on the fuselage tail.
2. Penetrate the pushrod into the vertical tail along the vertical tail groove.

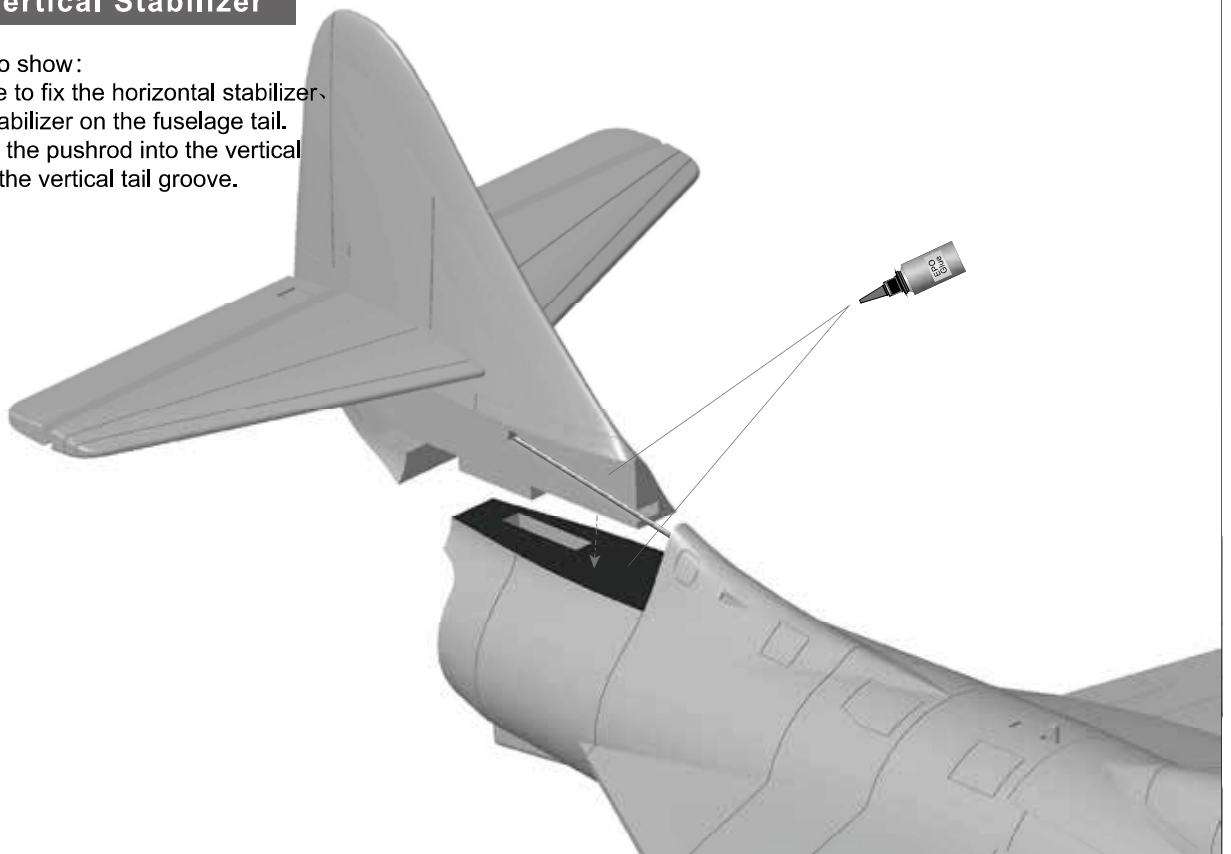

- 3. Penetrate the pushrod into the tail fuselage piece;
- 4. Install the tail fuselage piece on the fuselage by glue.

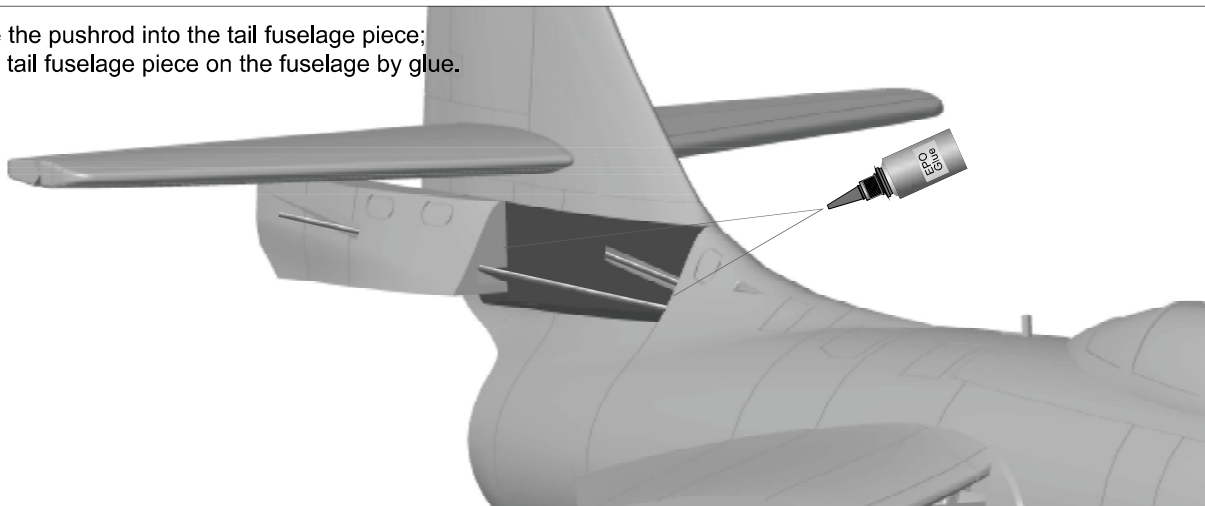

Install Battery

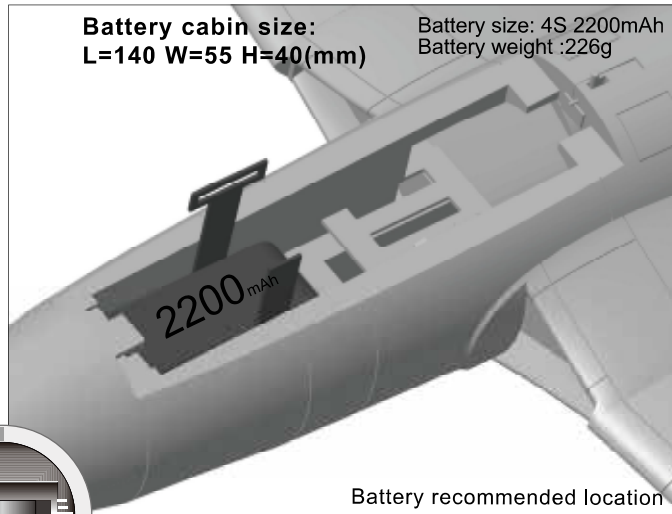
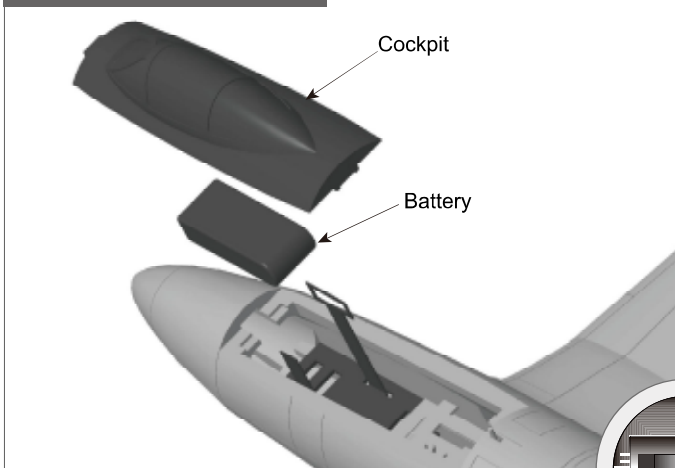

Battery cabin size:
L=140 W=55 H=40(mm)

Battery size: 4S 2200mAh
Battery weight :226g

Battery recommended location

Before connecting the battery and receiver, please switch on the transmitter power and make sure the throttle stick is in the lowest position. Bind your receiver to your transmitter according to your transmitter's instruction manual.

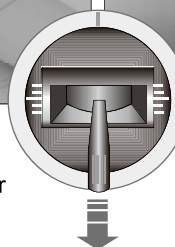

We recommend the following LiPo battery:
4S 14.8V 1600mAh~4S 14.8V 2200mAh
Discharge rate of C ≥ 35C

Pushrod instructions

Elevator pushrod length

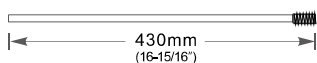

Pushrod diameter \varnothing 1mm

Elevator pushrod length



Main wing pushrod length

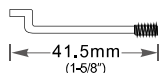

Pushrod diameter \varnothing 1.2mm

Main wing pushrod length



Important additional notes

The Y-type clevis used in this product is equipped with a transparent silicone ring for secondary reinforcement, which can effectively prevent the clevis from accidentally loosening.

As shown in the following figure, when you buckle the clevis into the control surface horn, use the silicone ring to cover the clevis.

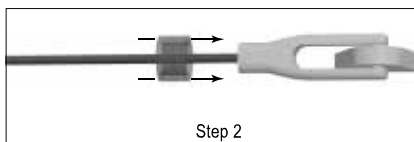
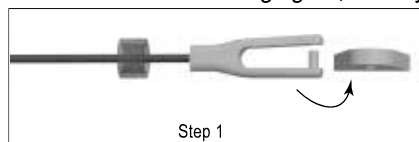

Center of Gravity

Correct Center of Gravity ("CG") is critical for enabling safe aircraft stability and responsive control. Please refer to the following CG diagram to adjust your aircraft's Center of Gravity.

- Depending on the capacity and weight of your chosen flight batteries, move the battery forward or backward to adjust the Center of Gravity.
- If you cannot obtain the recommended CG by moving the battery to a suitable location, you can also install a counterweight to achieve correct CG. However, with the recommended battery size, a counterweight is not required. We recommend flying without unnecessary counterweight.

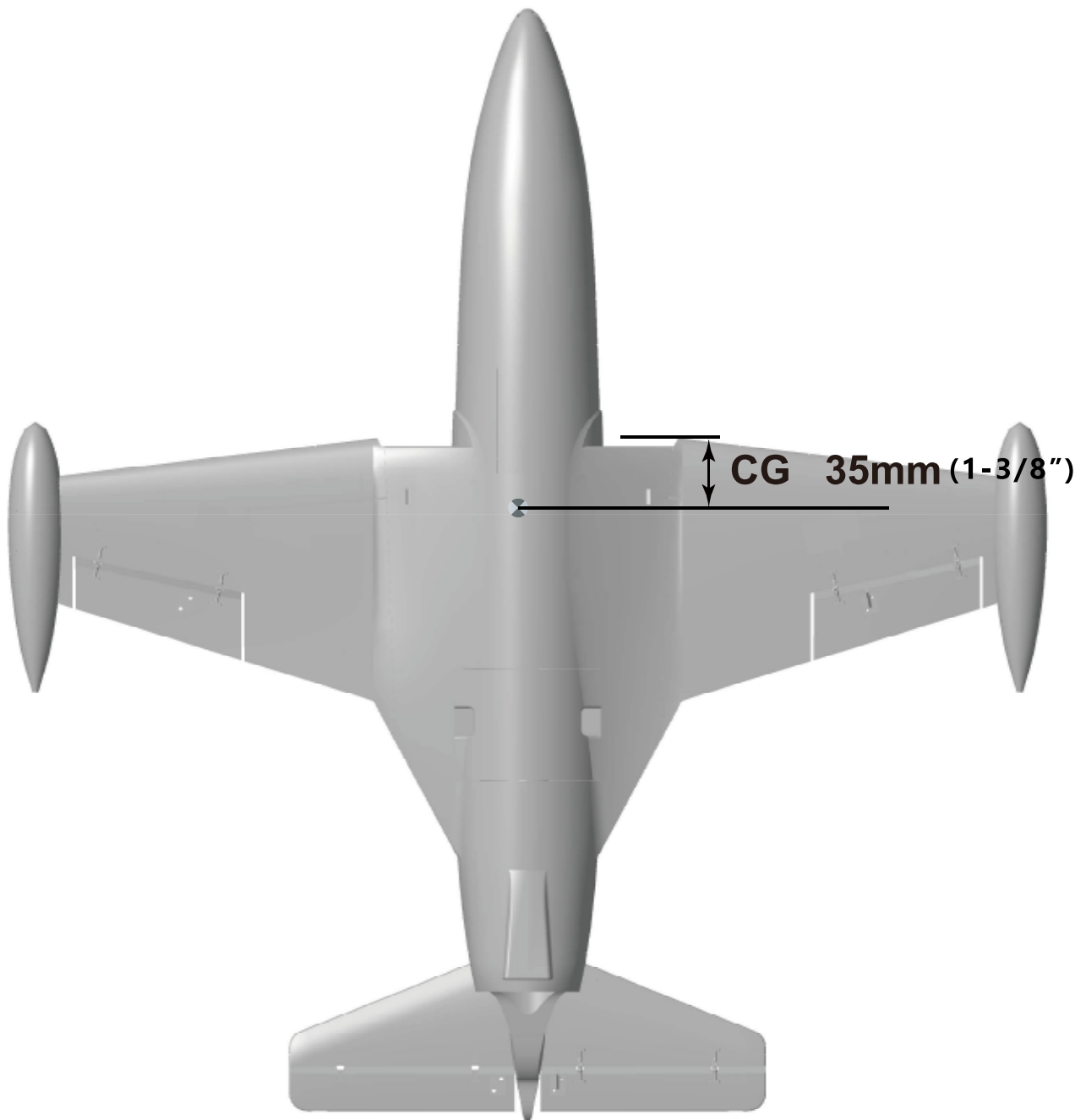

Control Direction Test

After installed the plane, before flying, we need a fully charged battery and connect to the ESC, then use radio to test and check that every control surface work properly.

Aileron

Stick Left



Stick Right



Elevator

Stick down

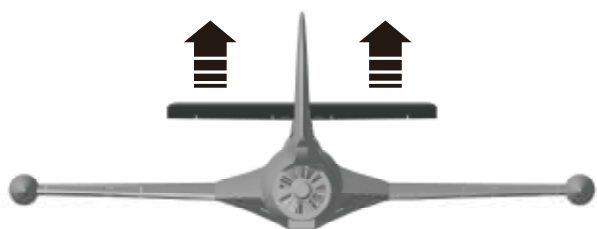

Stick up

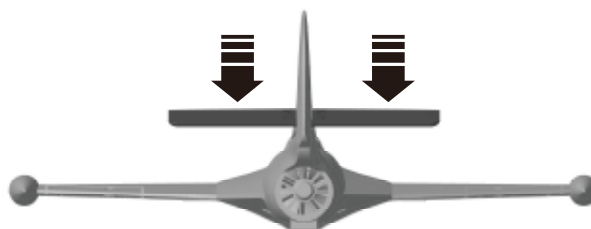

Dual Rates

According to our testing experience, use the following parameters to set Aileron/Elevator Rate. Program your preferred Exponential % in your radio transmitter. We recommend using High Rate for the first flight, and switching to Low Rate if you desire a lower sensitivity. On successive flights, adjust the Rates and Expo to suit your preference.

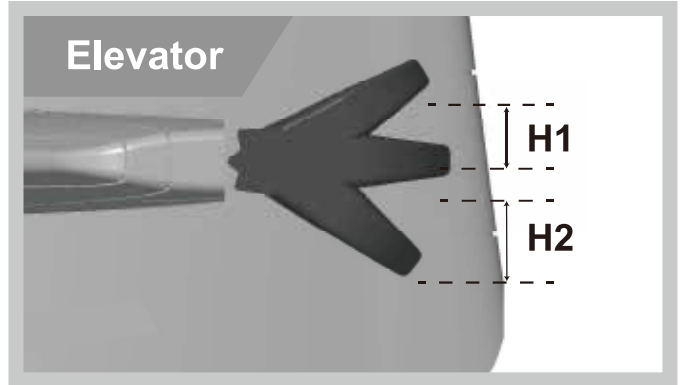
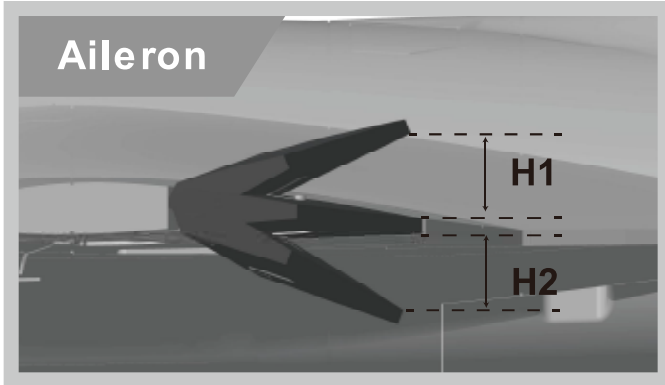

	Aileron (Measured closest to the fuselage)	Elevator (Measured closest to the fuselage)
Low Rate	H1/H2 7mm/7mm D/R Rate: 30%	H1/H2 7mm/7mm D/R Rate: 60%
High Rate	H1/H2 12mm/12mm D/R Rate: 50%	H1/H2 10mm/10mm D/R Rate: 80%

Remote Control EXP Setting Suggestion

1. Aileron EXP curve is shown as below :

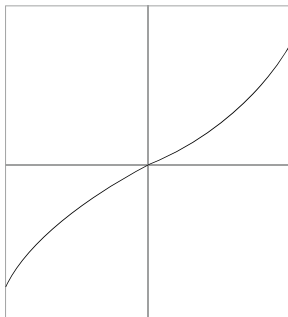

Futaba brand Remote Control : EXP A -30
EXP B -30
Spektrum brand Remote Control : EXPO 30% 30%

2. Elevator EXP curve is shown as below :

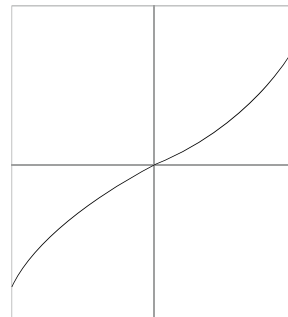

Futaba brand Remote Control : EXP A -30
EXP B -30
Spektrum brand Remote Control : EXPO 30% 30%

Servo Direction

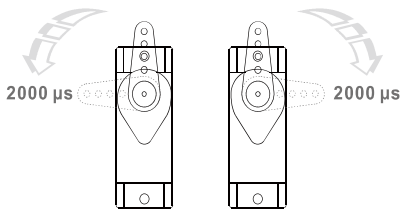

The servo positive or reverse rotation is defined as follows:
 When servo input signal change from 1000µs to 2000µs,
 The servo arm is **rotated clockwise**, its **positive servo**.
 The servo arm is **rotated counterclockwise**, its **reverse servo**.

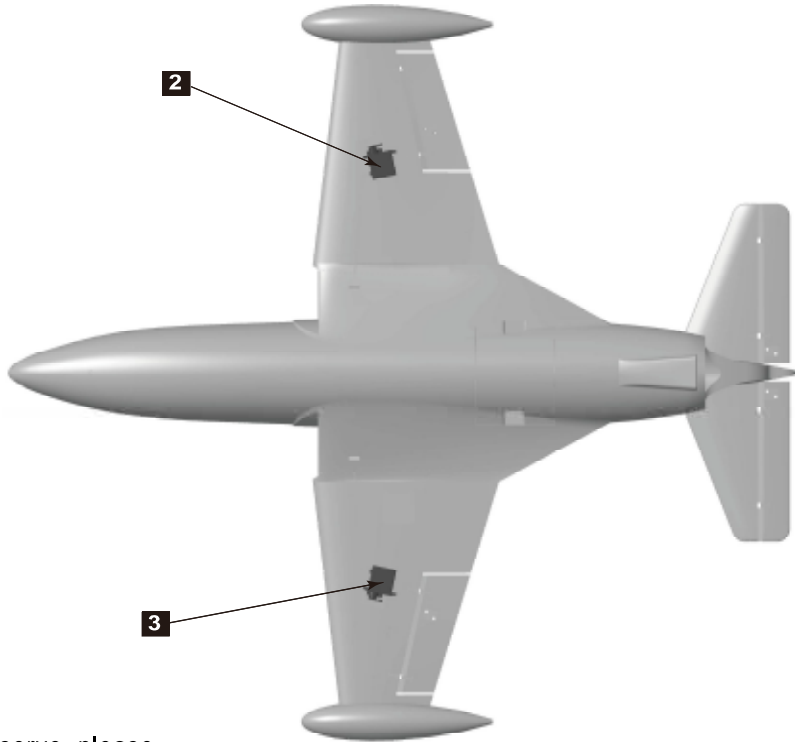
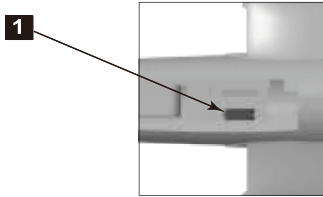

If you need to purchase another brand's servo, please refer to the following list to choose a suitable servo.

Position	Servo regulation	No.	Pos. / Rev.	Cable length
Fuselage	9g plastic servo	1	Positive	100mm
Main wing(L)	9g plastic servo	2	Positive	300mm
Main wing(R)	9g plastic servo	3	Positive	300mm

Motor Specification

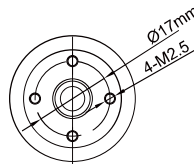
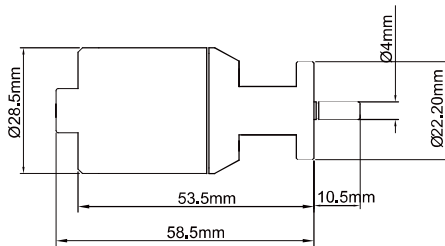
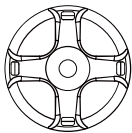

2840-2850

2840-2850KV brushless motor use 4S 14.8V lipo battery and 40A ESC.

⚠ Note: If you need other motor to use, please refer to the dimension shown on the left to select your motor, to make sure that the motor you purchased can install successfully.

Model	KV Value	Volute (V)	Current (A)	Pull (g)	RPM	Weight (g)	No Load Current	Propeller	ESC
2840-2850KV	2850RPM/V	14.8	40	1350	42180	145	2.7A	64mm Ducted Fan	40A

Landing gear is the optional part, please consult with the local distributor to purchase, and refer to the following instructions to install.

Please refer to the following photo for assembly and installation of the landing gear.

Install Nose Landing Gear

As the photo show:

1. Turn over the fuselage and remove the plastic piece on the install position of the front landing gear.

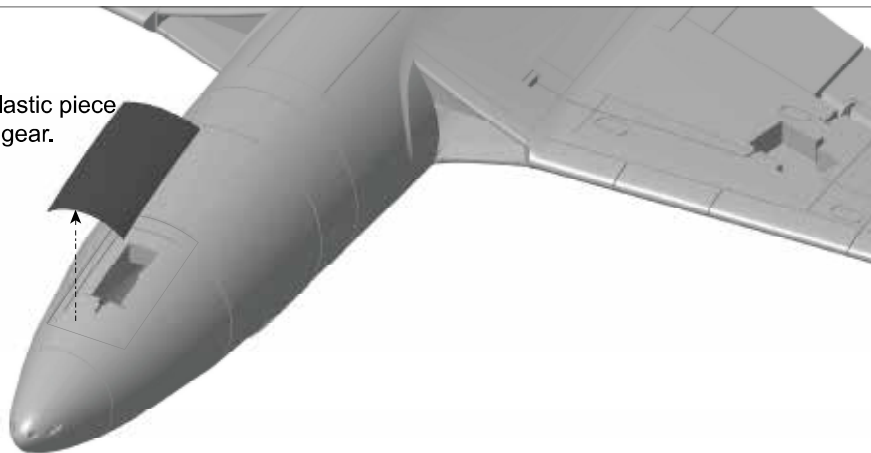

2. Install the nose landing gear on the fuselage by glue.

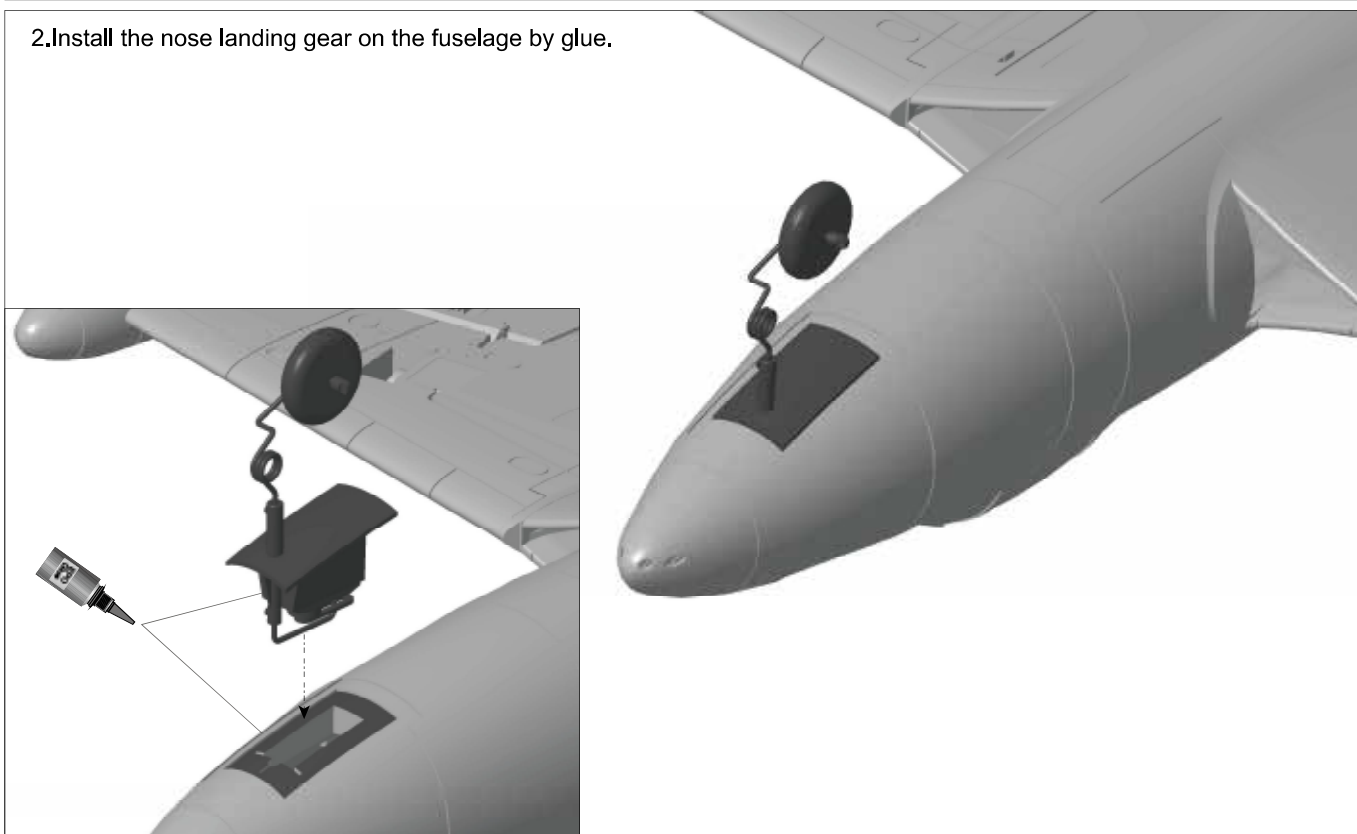

Landing gear is the optional part, please consult with the local distributor to purchase, and refer to the following instructions to install.

Please refer to the following photo for assembly and installation of the landing gear.

Install Rear Landing Gear

As the photo show :

1. Turn over the fuselage and remove the plastic piece on the install position of the main landing gear.

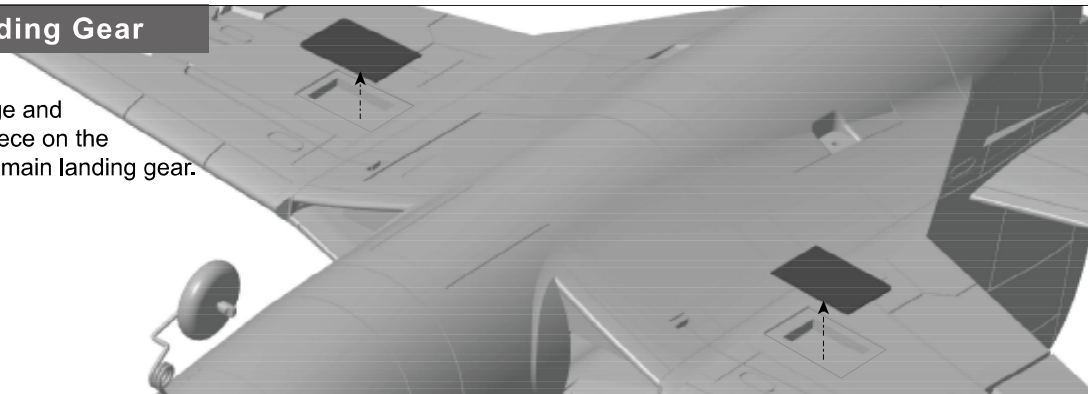

2. Install the main landing gear on the fuselage by glue.

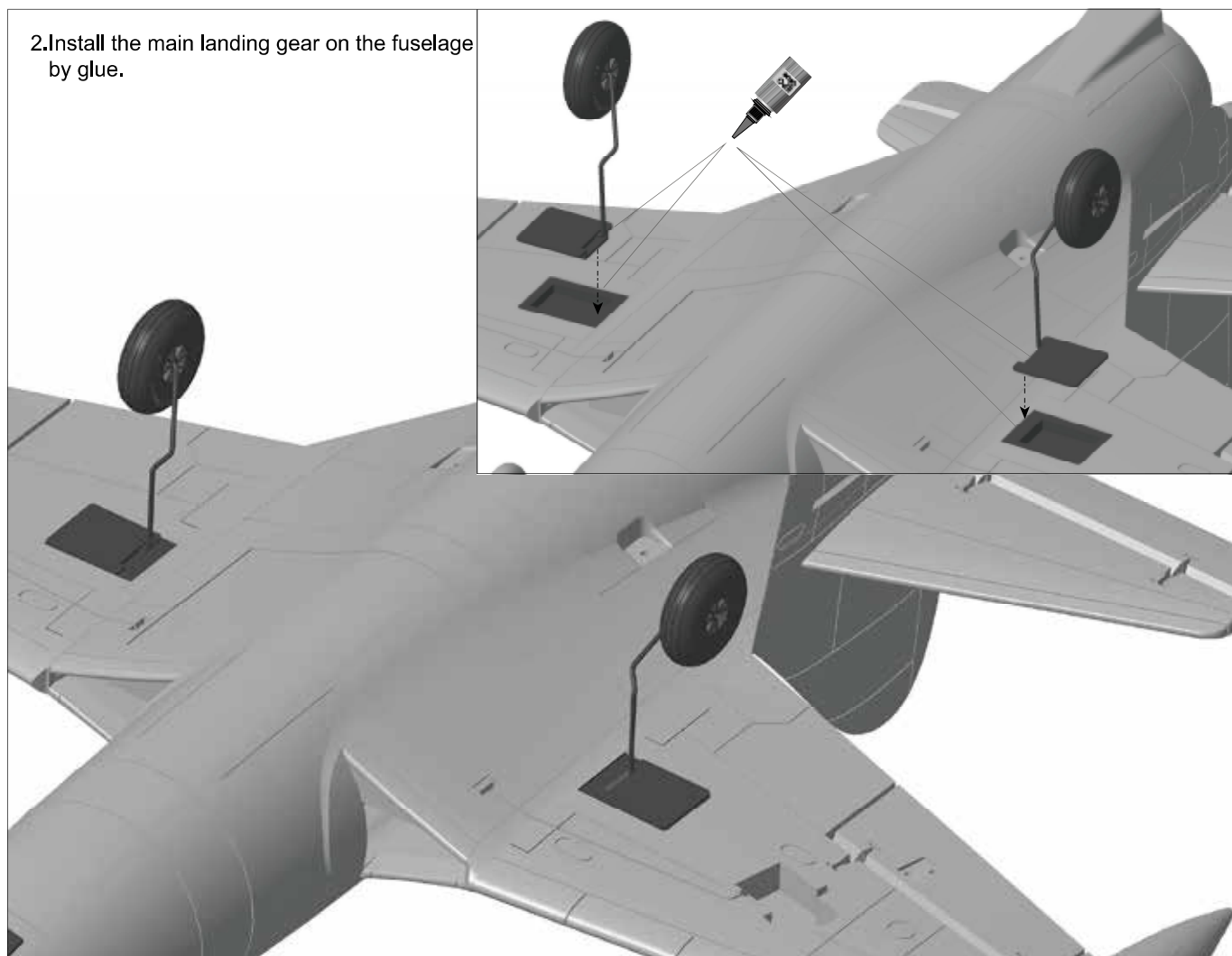



Dongguan Freewing Electronic Technology Ltd
HK Freewing Model International Limited

Add.: FeiYi Building, face to Labor Bureau, Fumin Middle Road, Dalang Town,
Dongguan City, Guangdong Province, China

Web: <http://www.sz-freewing.com> www.freewingmodel.com

Email: freewing@sz-freewing.com

Tel: 86-769-82669669 Fax: 86-769-82033233

东莞市飞翼电子科技有限公司
香港飞翼模型国际有限公司

地址: 广东省东莞市大朗镇富民中路402-408号飞翼楼二楼

Web: <http://www.sz-freewing.com> www.freewingmodel.com

Email: freewing@sz-freewing.com

Tel: 86-769-82669669 Fax: 86-769-82033233

