

70mm EDF Jet

# F9F-5 User Manual

Wingspan:1050mm

Length:1060mm

Empty Weight:1630G[w/o Battery]



MADE IN CHINA



EN 1~10

中 11~20

1	Introduction
2	Product Basic Information
2	Package list
3	PNP Assembly Instructions
3	Install Horizontal Tail
4	Install Vertical Tail
4	Install Main Wing
5	Install Nose Cone
5	Install Fuel Tank and Missiles
6	Battery Instructions
6	Pushrod Instructions
7	Center of gravity
8	Control Direction Test
9	Dual Rates
10	Servo Direction
10	Motor Specification

11	前言
12	产品规格参数
12	包装列表
13	PNP组装步骤介绍
13	平尾组装
14	垂尾组装
14	主翼组装
15	机头罩安装
15	油箱、导弹组装
16	电池介绍
16	舵面控制钢丝尺寸及安装孔位
17	重心示意图
18	模型舵面测试
19	舵量范围
20	舵机介绍
20	电机介绍

Thank you for purchasing our Freewing 70mm EDF super scale jet, F9F-5 Panther. Before you assemble this F9F-5 model jet, please carefully read the instructions and follow the correct process for assembly and adjustment. If you encounter problems during assembly and debugging, please first resolve them by referring to the instructions. If the problem persists, please contact the distributor or directly contact us.

The F9F Panther was a single engine straight wing jet fighter launched by the American company Grumman in 1946, and was one of the earliest aircraft equipped with ejection seats. This Freewing 1/11 scale F9F Panther 70mm EDF electric model jet uses EPO material, length is 1060mm, wing span is 1050mm and uses the plastic structure and carbon tubes to strengthen. The painting was based on the vehicle of Royce Williams during his mission in November 1952, during which he alone shot down four Soviet MiG-15 fighter jets. In addition, the weapon system has also been well restored, including a plastic cannon on the nose and six adhesive free wing mounts and rocket models.

The PNP version can be assembled without glue. Among them, the main wing adopts the screw-less "QUICK" portable install structure. It makes the use and storage of the aircraft more convenient. The Free Wing F9F Panther model jet uses electric retractable landing gear, while further improving the quality of the landing gear structure, with overall higher strength and smoother damping. When PNP at factory, it pre-installed with a 70mm 12 blade duct fan, a 2957-2010KV brushless in-runner motor, and an 80A ESC. Under this configuration, the maximum level flight speed reaches 170KM/H, and the powerful power brings a more enjoyable flying experience!

From the actual flying experience, after mastering the flight of smaller sized ducted aircraft, the F9F Panther 70mm EDF model jet is very suitable as an advanced model jet. It has excellent flight stability, even in a low-speed cruising state at 30% throttle, still with excellent performance. Powerful power and fast power response make it very easy to complete various routine flight maneuvers. With the use of flaps, the aircraft can land at a slower speed and shorten the landing distance.

Thank you again. I hope this new F9F-5 Panther model jet can bring you a better experience. I wish you a successful flight!

## Note:

- 1.This is not a toy! Operator should have a certain experience, beginners should operate under the guidance of professional players.
- 2.Before install, please read through the instructions carefully and operate strictly under instructions.
- 3.Cause of wrong operation, Freewing and its vendors will not be held responsible for any losses.
- 4.Model planes' players must be on the age of 14 years old.
- 5.This plane used the EPO material with surface spray paint, don't use chemical to clean, otherwise it will damage.
- 6.You should be careful to avoid flying in areas such as public places, high-voltage-intensive areas, near the highway, near the airport or any other place where laws and regulation clearly prohibit.
- 7.You cannot fly in bad weather conditions such as thunderstorms, snows....
- 8.Model plane's battery, don't allowed to put in everywhere. Storage must ensure that there is no inflammable and explosive materials in the round of 2M range.
- 9.Damaged or scrap battery should be properly recycled, it can't discard to avoid spontaneous combustion and fire.
- 10.In flying field, the waste after flying should be properly handled, it can't be abandoned or burned.
- 11.In any case, you must ensure that the throttle is in the low position and transmitter switch on, then it can connect the lipo-battery in aircraft.
- 12.Do not try to take planes by hand when flying or slow landing process. You must wait for landing stop, then carry it.

**⚠ NOTE:** This is not a toy. Not for children under 14 years. Young people under the age of 14 should only be permitted to operate this model under the instruction and supervision of an adult. Please keep these instructions for further reference after completing model assembly.

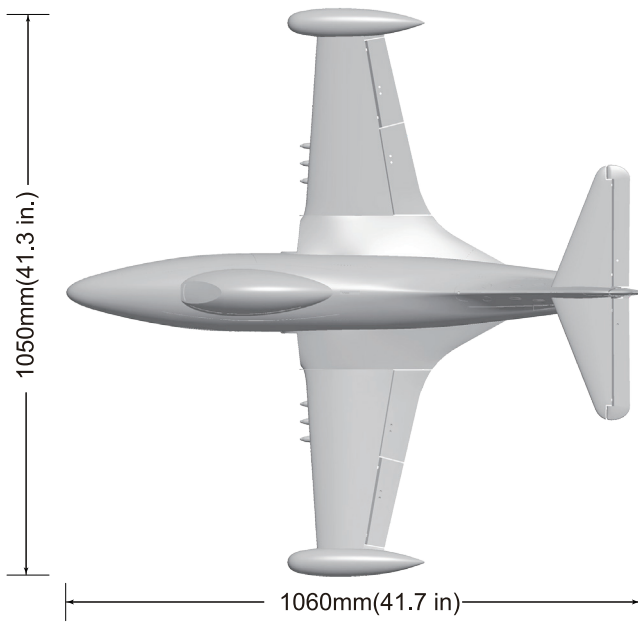

### Standard Version

Wingload: 95.8 g/dm<sup>2</sup>  
 Wing Area: 22.5 dm<sup>2</sup>  
 Servo: 9gHybrid digital servo(8pcs)  
 Motor: 2957-2210KV I/R Motor  
 Ducted fan: 70mm 12-blade fan  
 ESC: 80A Brushless(7A UBEC)  
 Weight: 1630g(w/o Battery)

### Other Notes

Landing gear: Electric landing gear  
 Li-Po Battery: 6S 3500-5000mAh

**⚠ Note:** The parameters in here are derived from test result using our accessories. If use other accessories, the test result will be different. Any problem since of using other accessories, we are not able to provide technical support.

# Package List

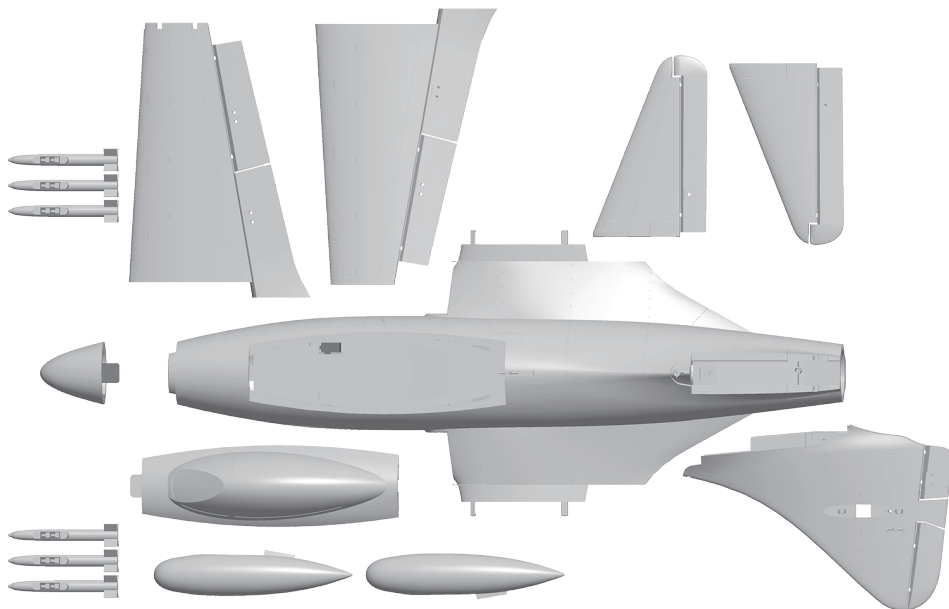

Different equipment include different spareparts. Please refer to the following contents to check your sparepart list.

No.	Name	PNP	ARF Plus	No.	Name	PNP	ARF Plus
1	Fuselage	Pre-installed all electronic parts	Pre-installed servo	6	Cockpit	✓	✓
2	Main wing	Pre-installed all electronic parts	Pre-installed servo	7	Landing gear	✓	✓
3	Horizontal tail	Pre-installed all electronic parts	Pre-installed servo	8	Annex bag	✓	✓
4	Vertical tail	Pre-installed all electronic parts	Pre-installed servo	9	Missile	✓	✓
5	Nose cone	✓	✓	10	Manual	✓	✓



**Install Horizontal Tail**

As the photo show:

1. Insert the horizontal tail into the vertical tail. And use a traction steel wire to pull out the servo cable along the vertical tail groove.
2. After installing the horizontal tail, tighten it with screws.  
(Repeat this step on the other side.)

Screw (KM3\*7mm 4PCS)

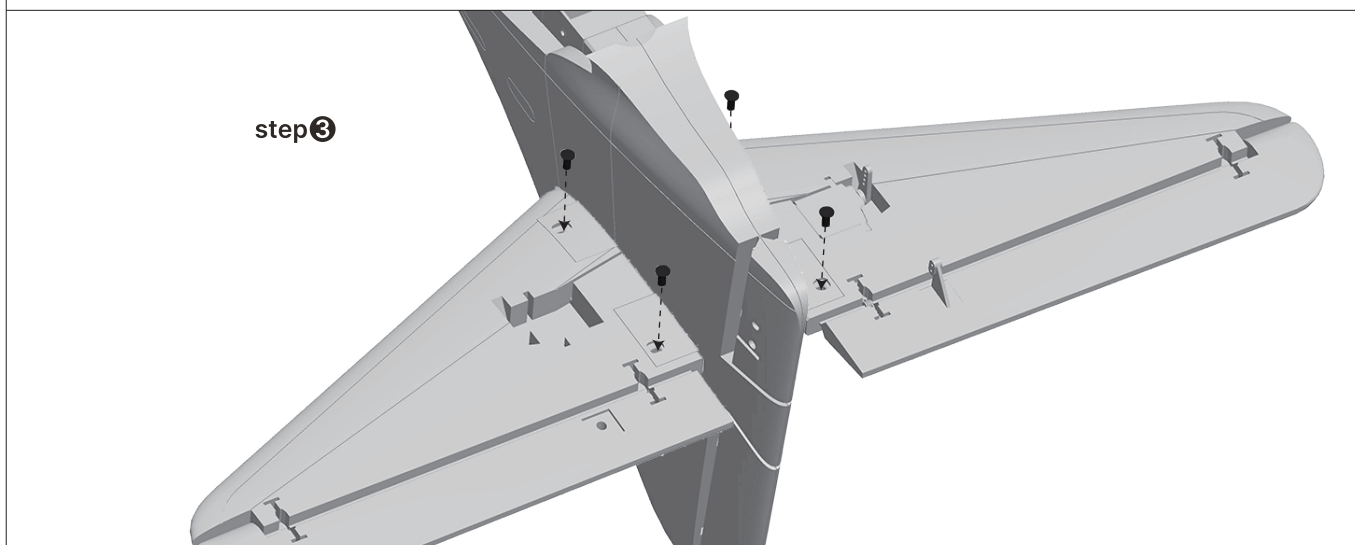
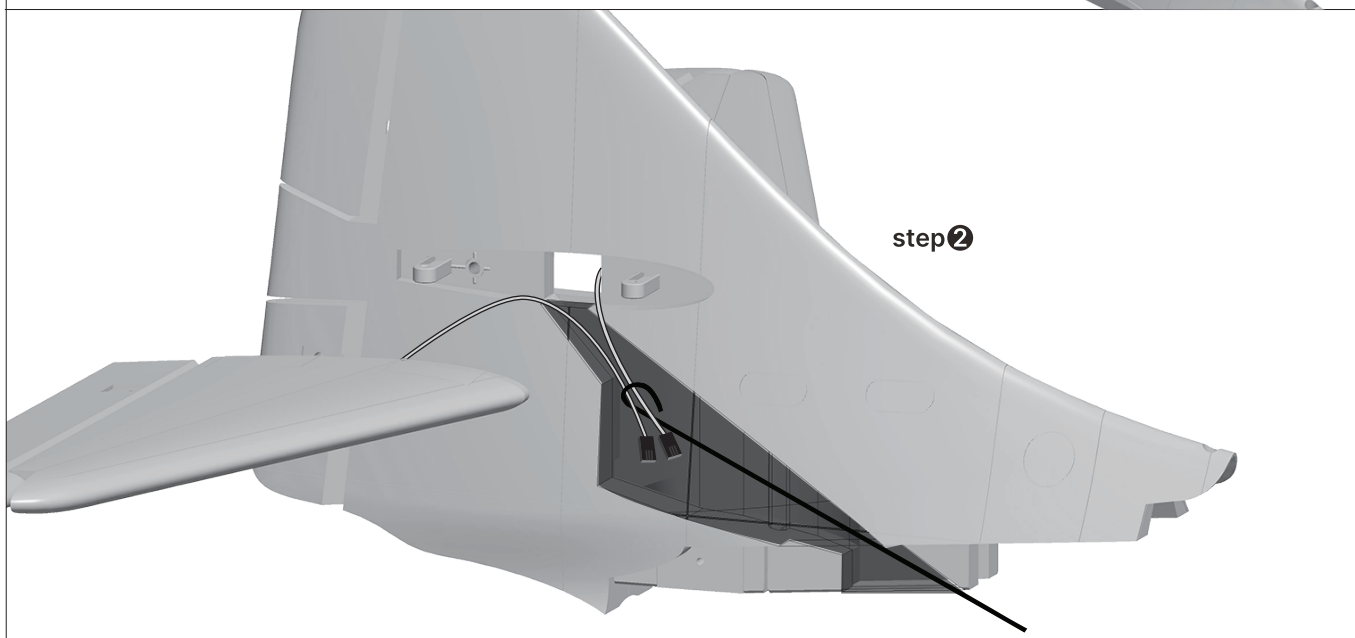
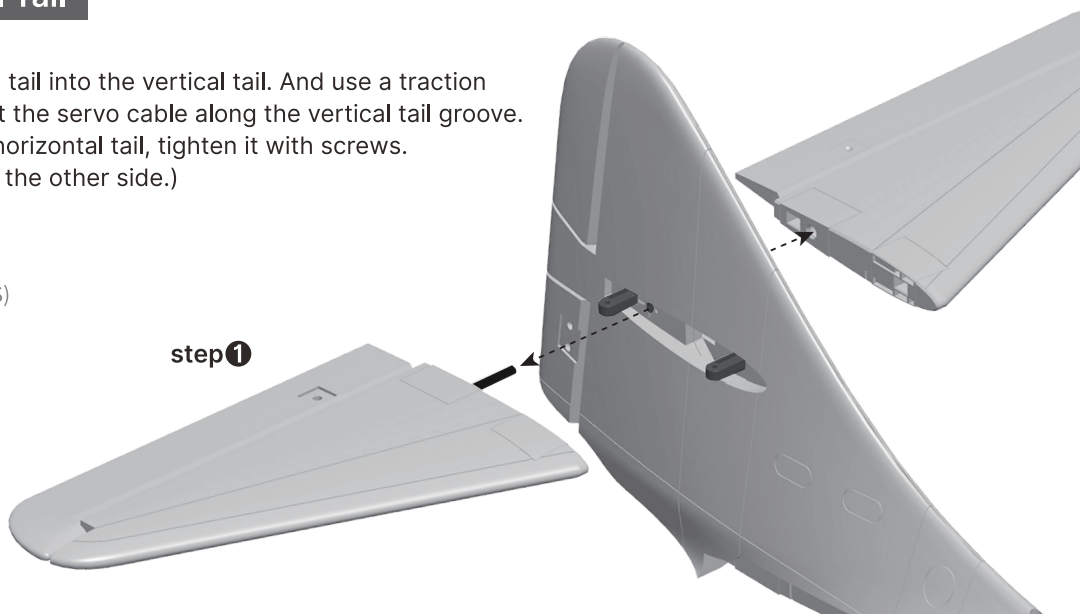

## Install Vertical Tail

As the photo show:

1. Insert the vertical tail and horizontal tail servo wires respectively onto the tail control board.
2. After installing the vertical tail onto the fuselage, tighten it with three screws.

Screw (KM3\*7mm 4PCS)

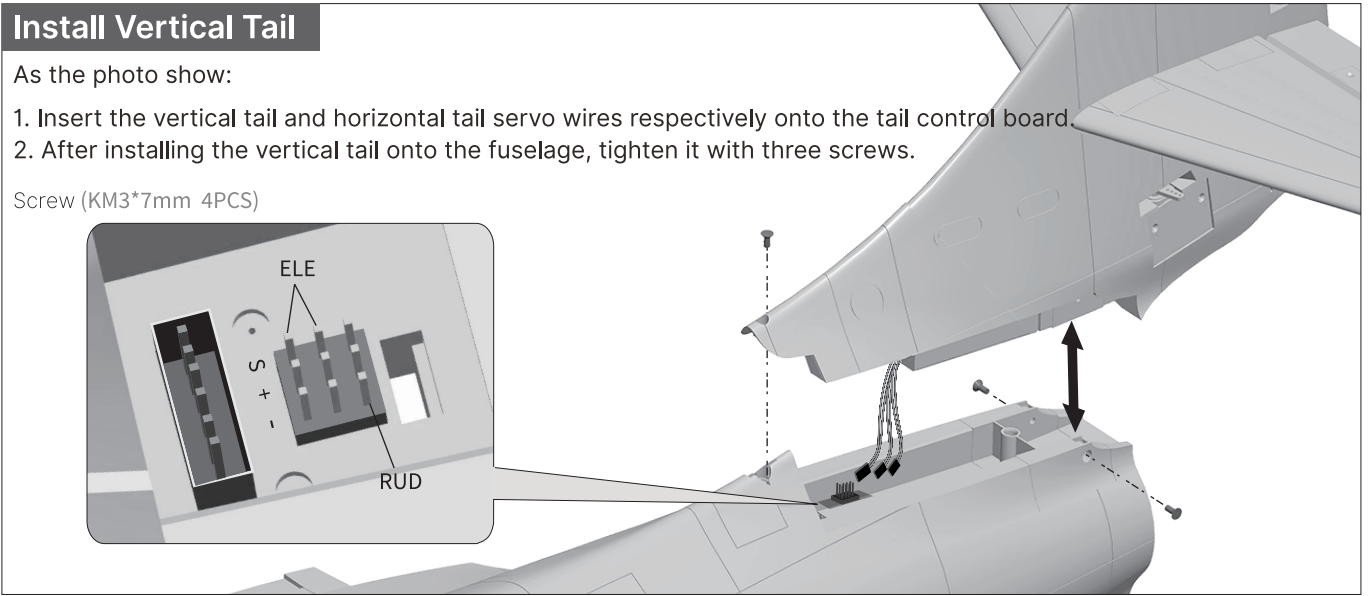
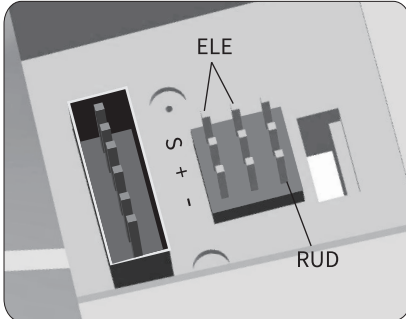

## Install Main Wing

1. Align the carbon tube with the fuselage, connect the ribbon wire to the main wing control board and push the main wing into the installation position on the fuselage;
2. When a slight "click" sound is heard, it indicates that the main wing has been installed;
3. Check and confirm that the latch lever on the lower surface of the main wing is in a locked state.<sup>①</sup>  
(Repeat this step on the other side.)

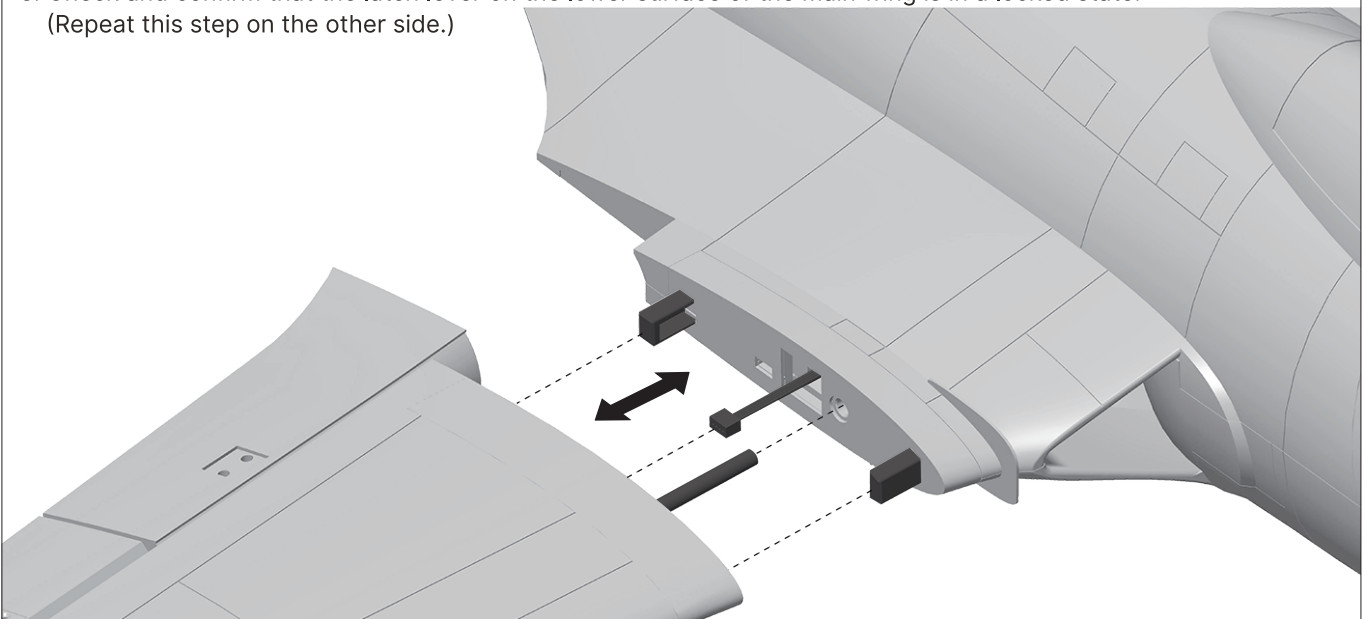

① Three different states of the latch toggle lever is as the photo shown:

**Latch toggle lever lock status**

As the photo show, the front/rear lever is in outside end point

When unlocking, it is necessary to manually push the front and rear toggle levers towards the middle at the same time.



**Latch toggle lever unlock status**

As the photo show, the front/rear lever is in inside end point

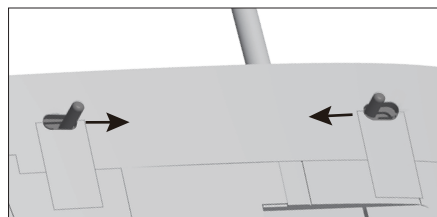

**The latch toggle lever abnormal status**

As the photo show, the front/rear lever is not in outside or inside end points

After installed the main wing, please check carefully. If happen the abnormal status, it is necessary to manually push the latch toggle lever to reset.



### Install Nose Cone

As the photo show:

1. Install the nose cone onto the fuselage

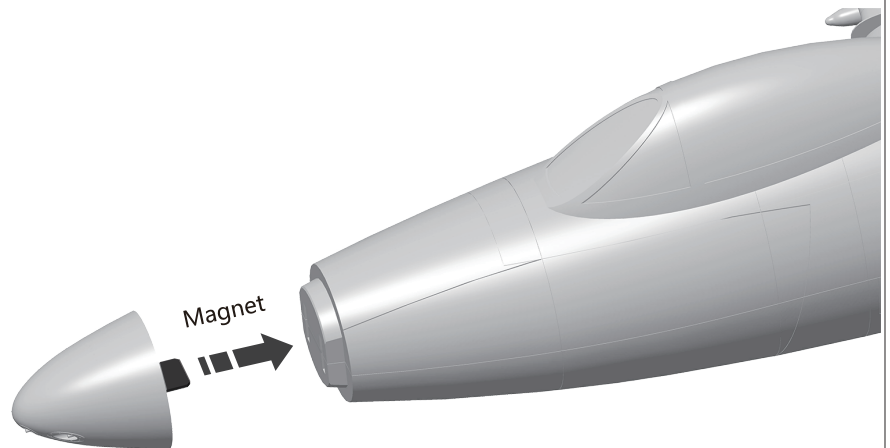

### Install Fuel Tank

As the photo show:

1. Insert the fuel tank into the main wing and tighten it with two screws.
2. Repeat this step for the other fuel tank.

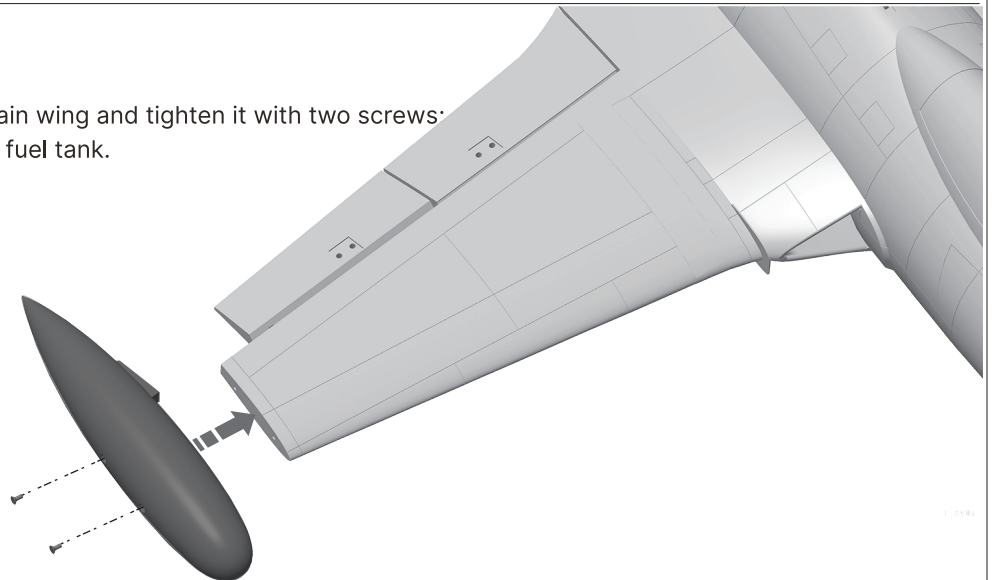

### Install Missiles

As the photo show:

1. Install the missile on the fuselage;
2. Repeat this step for the missile on the other side.

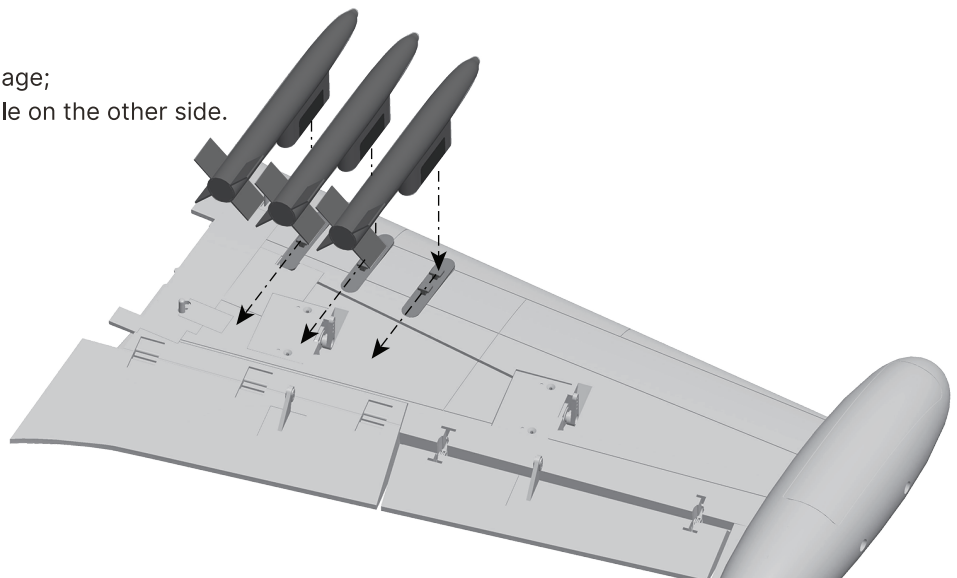

## Install Battery

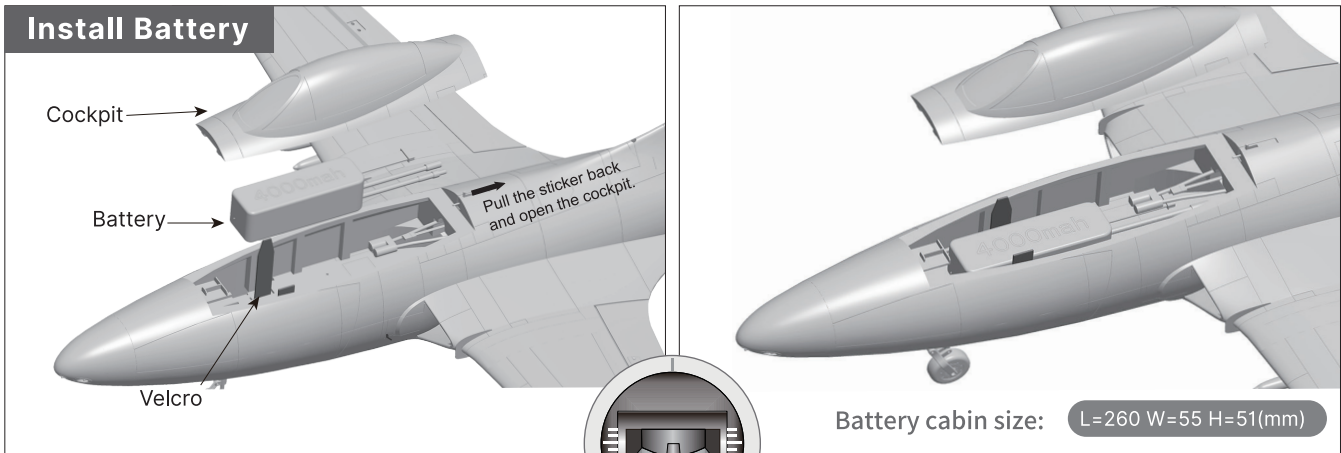

Before connecting the battery and receiver, please switch on the transmitter power and make sure the throttle stick is in the lowest position. Bind your receiver to your transmitter according to your transmitter's instruction manual.

We recommend the following LiPo battery:  
**6S 22.2V 3500mAh~6S 22.2V 5000mAh (1pcs)**  
 Discharge rate of C ≥35C

## Pushrod Instructions

### Aileron pushrod length

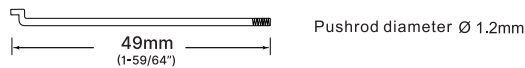

### Aileron pushrod mounting hole

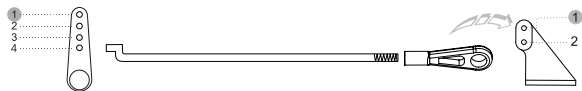

### Rudder pushrod length

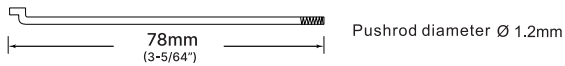

### Rudder pushrod mounting hole

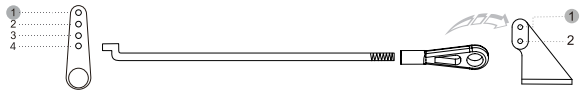

### Flap pushrod length

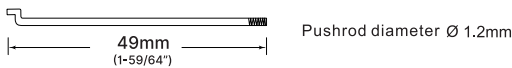

### Flap pushrod mounting hole(Inside)

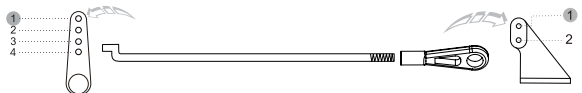

### Elevator pushrod length

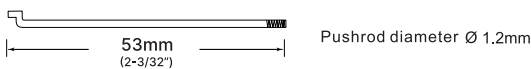

### Elevator pushrod mounting hole



### Nose gear steering pushrod length

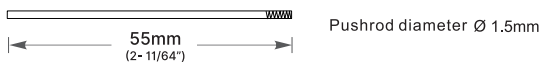

### Nose gear steering pushrod mounting hole



## Center of Gravity

Correct Center of Gravity ("CG") is critical for enabling safe aircraft stability and responsive control. Please refer to the following CG diagram to adjust your aircraft's Center of Gravity.

- Depending on the capacity and weight of your chosen flight batteries, move the battery forward or backward to adjust the Center of Gravity.
- If you cannot obtain the recommended CG by moving the battery to a suitable location, you can also install a counterweight to achieve correct CG. However, with the recommended battery size, a counterweight is not required. We recommend flying without unnecessary counterweight.

As the photo show, We marked the center of gravity on the bottom of the Main wing. Please confirm the CG based on this marked position.

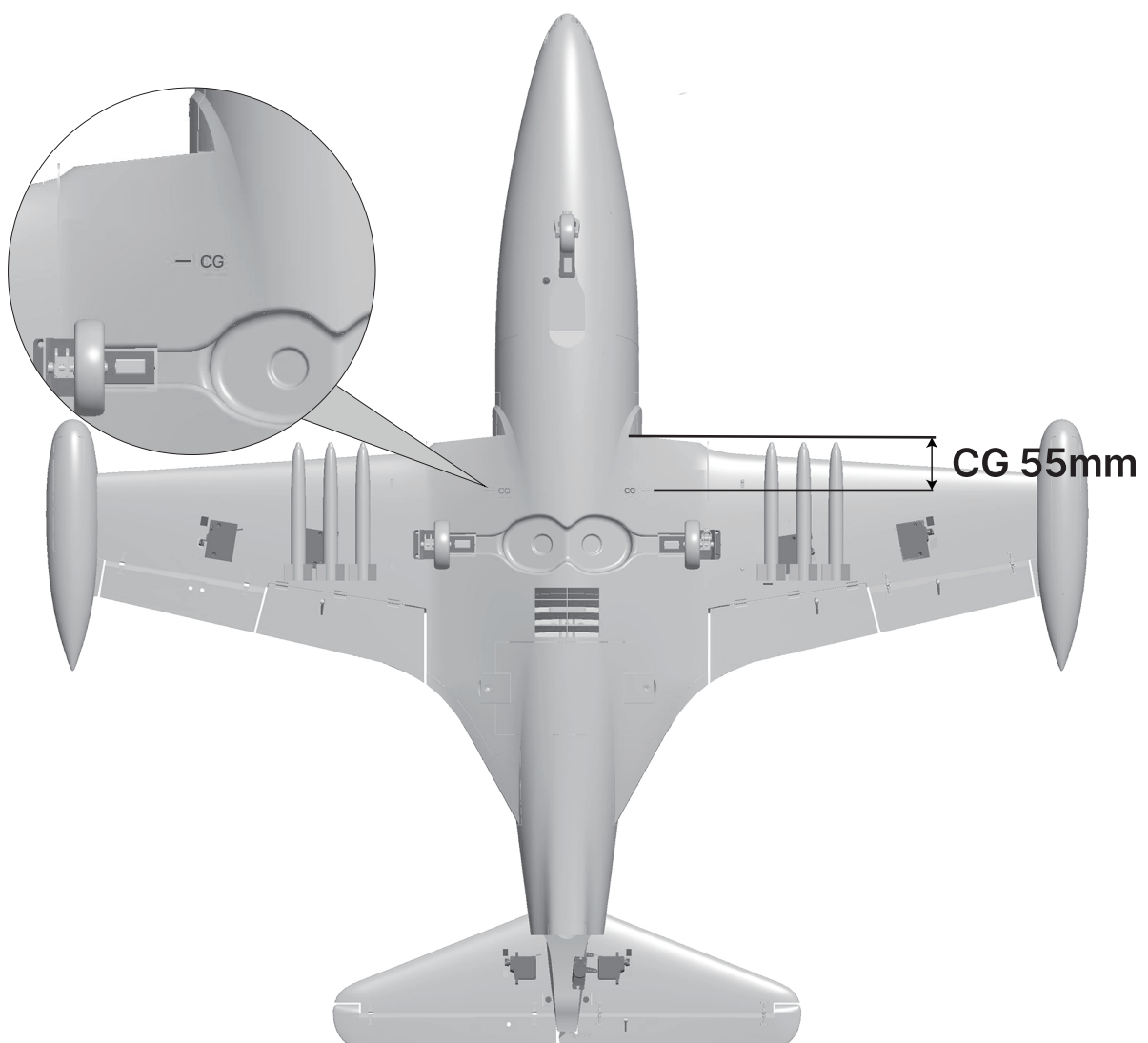

After installed this F9F model plane, please connect to the receiver and power on, then adjust it.

1. When all channels of radio are fine tuned to zero and the control stick is centered: check whether each control surface on the aircraft is in the center position. If it is found that the control surface is not in the center position, please adjust the control rod to center it;
2. Please refer to the diagram below and use the radio to test each control surface to ensure that its movement direction matches the diagram. If the opposite movement occurs, first check whether the relevant channel in the radio has enabled the reverse function; If the problem persists, please contact us for assistance in resolving it.

## Aileron

Stick Left

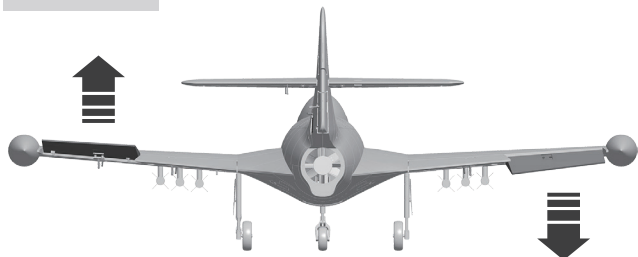

Stick Right

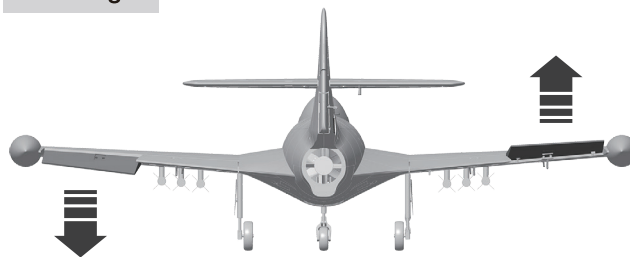

## Rudder

Stick Left



Stick Right

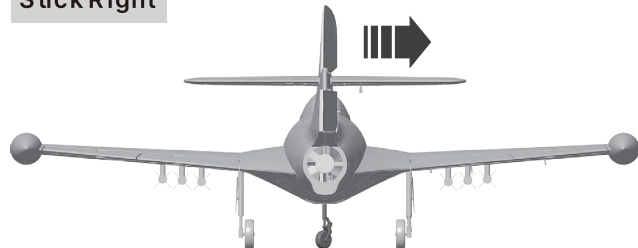

## Elevator

Stick down

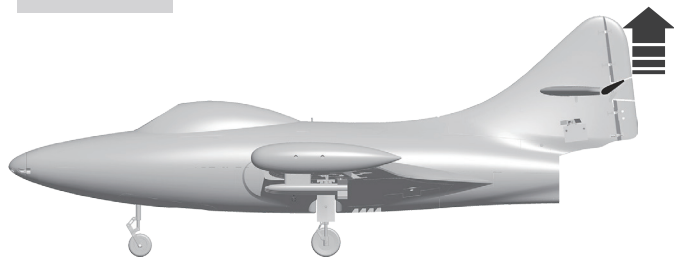

Stick up

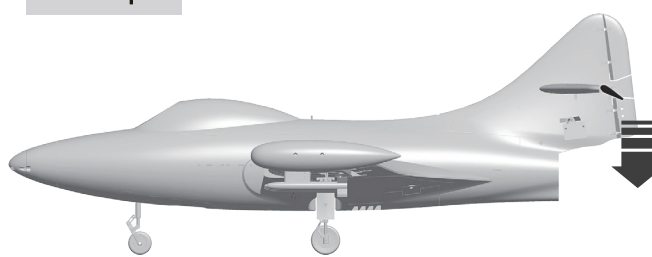

## Flaps

Flaps down

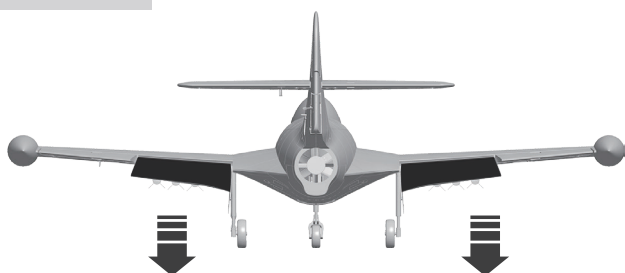



## Dual Rates

According to our testing experience, use the following parameters to set Aileron/Elevator Rate. Program your preferred Exponential % in your radio transmitter. We recommend using High Rate for the first flight, and switching to Low Rate if you desire a lower sensitivity. On successive flights, adjust the Rates and Expo to suit your preference.

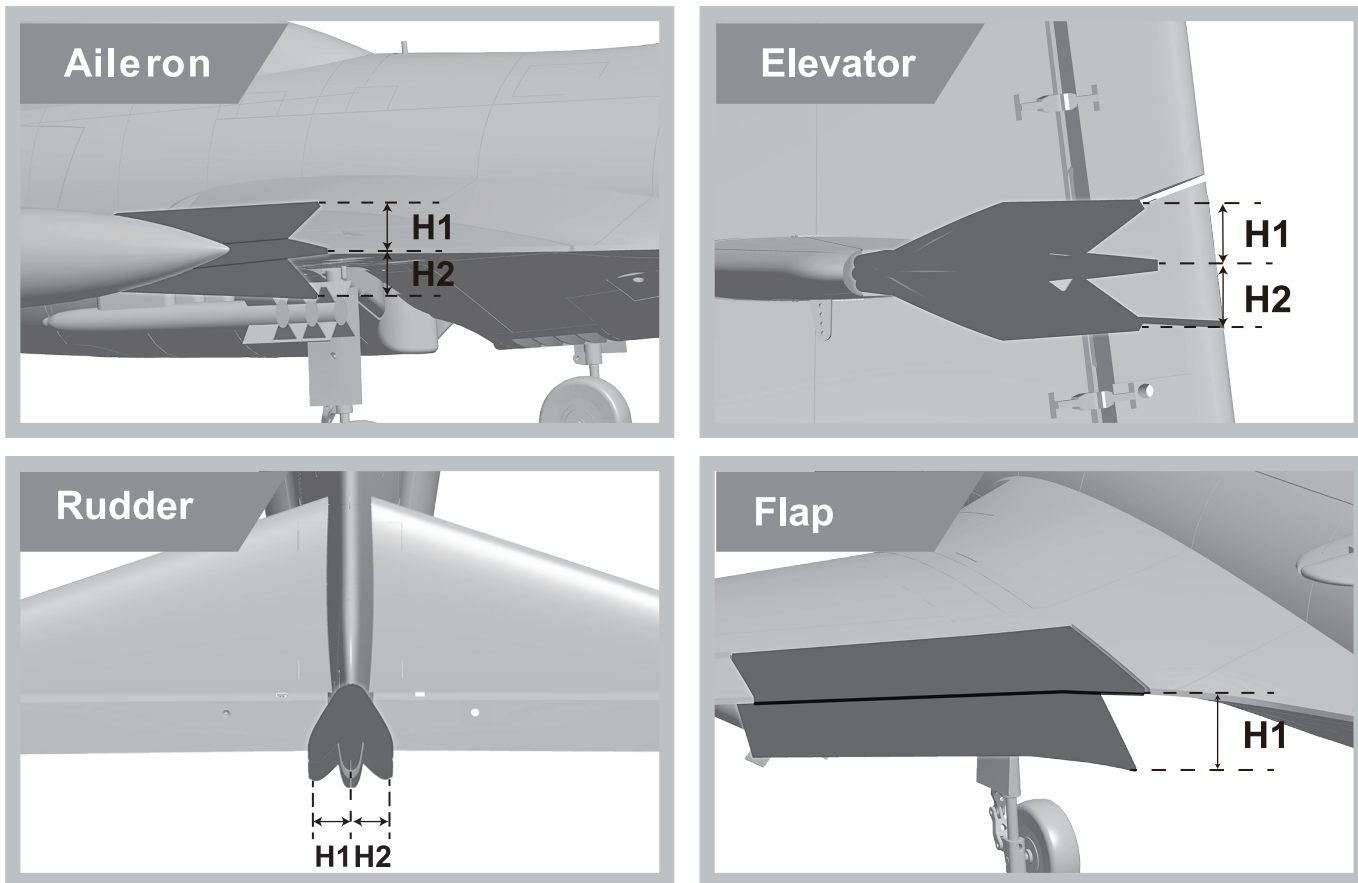

	<b>Aileron</b> (Measured closest to the fuselage)	<b>Elevator</b> (Measured closest to the fuselage)	<b>Rudder</b> (Measured from the bottom)	<b>Flaps</b>
<b>Low Rate</b>	H1/H2 13mm/13mm D/R Rate: 80%	H1/H2 9mm/9mm D/R Rate: 80%	H1/H2 13mm/13mm D/R Rate: 80%	H1 18mm
<b>High Rate</b>	H1/H2 16mm/16mm D/R Rate: 100%	H1/H2 11mm/11mm D/R Rate: 100%	H1/H2 16mm/16mm D/R Rate: 100%	H1 30mm

## Remote Control EXP Setting Suggestion

<p>1. Aileron EXP curve is shown as below :</p> <p>Futaba brand Remote Control : EXP A -30 EXP B -30 Spektrum brand Remote Control : EXPO 30% 30%</p>	<p>2. Elevator EXP curve is shown as below :</p> <p>Futaba brand Remote Control : EXP A -30 EXP B -30 Spektrum brand Remote Control : EXPO 30% 30%</p>	<p>3. Rudder EXP curve is shown as below :</p> <p>Futaba brand Remote Control : EXP A -30 EXP B -30 Spektrum brand Remote Control : EXPO 30% 30%</p>
---	--	--

## Servo Direction

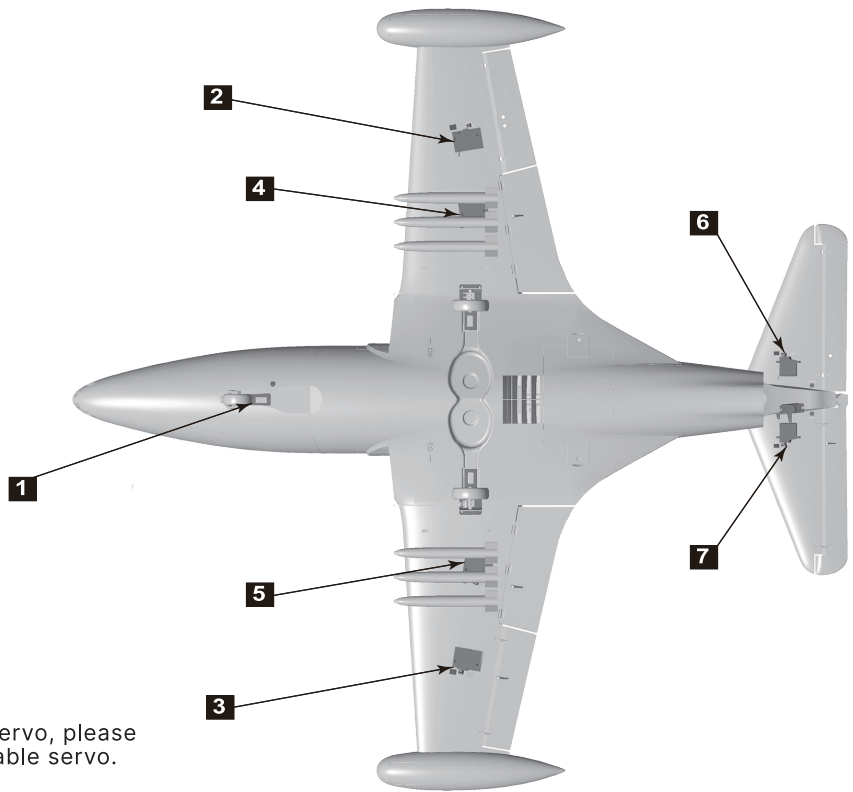
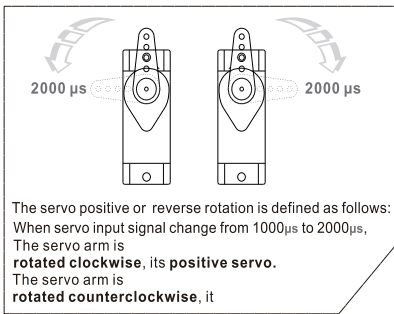

If you need to purchase another brand's servo, please refer to the following list to choose a suitable servo.

Position	Servo regulation	No.	Pos. / Rev.	Cable length
Nose gear steering servo	9g Digital-Hybrid	1	Reverse	200mm
Aileron(L)	9g Digital-Hybrid	2	Positive	200mm
Aileron(R)	9g Digital-Hybrid	3	Positive	200mm
Flap(L)	9g Digital-Hybrid	4	Positive	200mm
Flap(R)	9g Digital-Hybrid	5	Positive	200mm
Elevator(L)	9g Digital-Hybrid	6	Positive	300mm
Elevator(R)	9g Digital-Hybrid	7	Reverse	300mm
Rudder	9g Digital-Hybrid	8	Positive	200mm

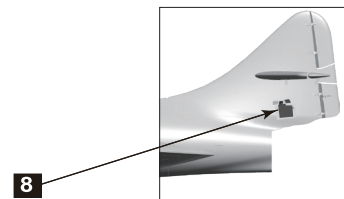

## Motor Specification

Item No. MI029571  
2957-2210KV

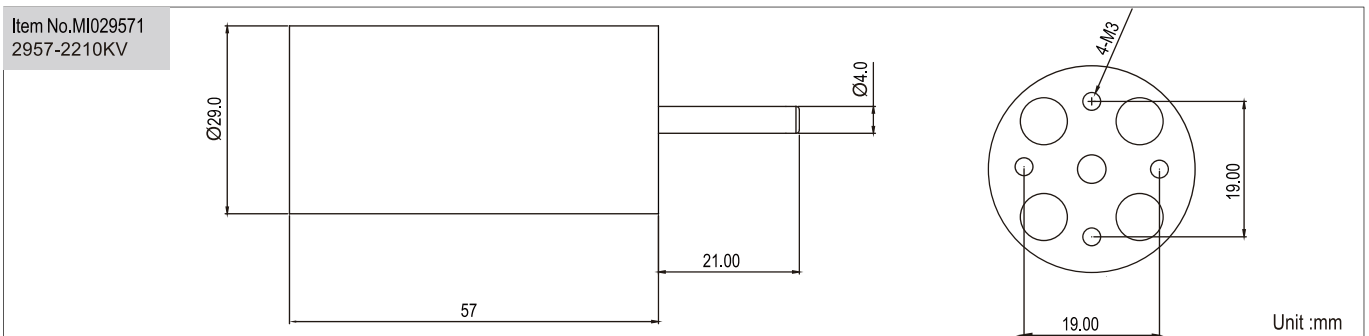

Item No.	Motor size	Motor(KV)	Thrust(g)	Current(A)	Use Voltage (V)	Use ESC (A)	EDF Weight (g)	Max power (W)	Efficiency (g/w)
E7218	2957-2210KV	2210KV	2600	70	22.2 (6S)	80	240	1550	1.68



**Dongguan Freewing Electronic Technology Ltd**  
**HK Freewing Model International Limited**

Address: FeiYi Building, 402-408#, Fumin Middle Road, Dalang Town,  
Dongguan City, Guangdong Province, China

Web: <http://www.sz-freewing.com> [www.freewingmodel.com](http://www.freewingmodel.com)

Email: [freewing@sz-freewing.com](mailto:freewing@sz-freewing.com)

Tel: 86-769-82669669 Fax: 86-769-82033233

东莞市飞翼电子科技有限公司  
香港飞翼模型国际有限公司

地址: 广东省东莞市大朗镇富民中路402-408号飞翼楼四楼

Web: <http://www.sz-freewing.com> [www.freewingmodel.com](http://www.freewingmodel.com)

Email: [freewing@sz-freewing.com](mailto:freewing@sz-freewing.com)

Tel: 86-769-82669669 Fax: 86-769-82033233

