

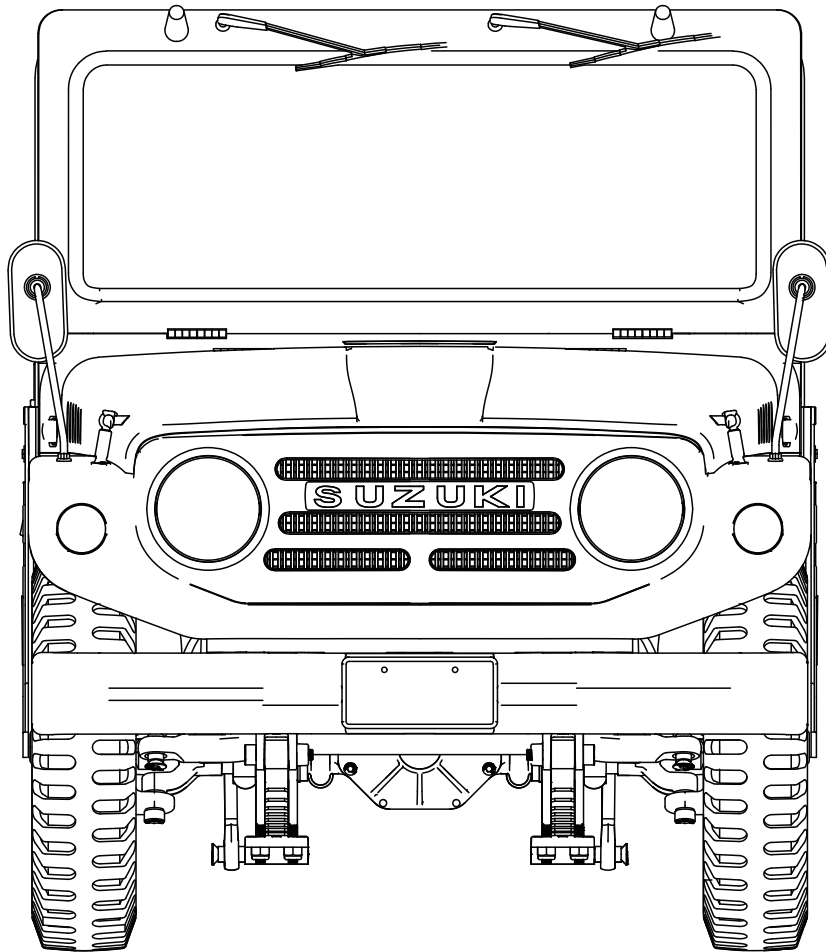

1:6 JIMNY



Instruction Manual

操作手册

SPECIFICATION

Length: 546mm
Width: 233mm

Height: 265mm
Wheel base: 330mm

Ground clearance: 50mm
Approach angle: 41°

Departure angle: 48°

TABLE OF CONTENTS

INTRODUCTION 02

TRANSMITTER INTRUCTION 02

THROTTLE STICK POSITION 08

OPERATING THE VEHICLE 11

ASSEMBLING 11

SETTING THE GEAR MESH 12

CHARGING THE BATTERY 12

CE WARNING 14

APPENDIX 1 FCC STATEMENT 14

WHEELS ASSEMBLY 27

CAR WINDOW ASSEMBLY 27

SEAT ASSEMBLY 28

STEERING LINKAGE ASSEMBLY 28

STEERINGSERVO 29

FRONT AXLE ASSEMBLY 29

REAR AXLE ASSEMBLY 30

TRANSMISSION GEAR BOX ASSEMBLY 30

TRANSMISSION SHAFT ASSEMBLY 31

MAIN GEAR BOX ASSEMBLY 31

OIL SHOCK ABSORBERS ASSEMBLY 32

CAR BODY ASSEMBLY 32

CAR BODY FINISHING 33

GENERAL LIST OF ACCESSORIES (I) 34

GENERAL LIST OF ACCESSORIES (II) 35

Introduction

Jimny, a legendary car, which successfully filled the market gap with its small displacement, small size, low price and unique market position, was born to break the traditional views on off-road vehicles and demonstrated itself as a reliable tool for off-road enthusiasts.

The predecessor of the Jimny was the Hope Star ON 4WD of Hope Motors, which was sold to Suzuki Motor in 1968. 1970 saw the introduction of the LJ10 weighing 600kg with a 359cc two-stroke inline twin-cylinder equipped.

FMS is proud to present this 1/6 scale officially licensed Jimny LJ1. It boldly adopts a metal beam, non-load bearing chassis, front and rear leaf spring suspension and universal joints. The soft-rubber-wrapped seats feature a cushion like softness and can be collapsed, making them a perfect match for 1/6 figures.

Power switch and maintenance is more convenient as motor, ESC, receiver and battery are all delicately integrated under the hood. Just open the hinged hood for full access.

Marvelous interior detailing is on full display, from the adjustable windshield and safety bars at the door positions on both sides, the real-lenses mirrors, to the linked steering wheel; from the miniature shadow instrument panel, mechanical buttons, to the manual gearshift, foot pedal set and so on.

Different scale styling can be achieved with the large rear bucket space, perfect for various simulated parts when the tailgate is lowered and the spare tire carrier is opened to the right.

The black adjustable anti-roll bar provides convenient methods for the upgrade of parts in various materials and styles. In terms of lighting, the headlights are always on by default, while the front and rear turn signals and taillights are reserved for light bead positions, which is convenient for upgrading the lighting system.

Transmitter instruction

The FS-G4P is a simple 4 channel transmitter using the latest AFHDS 2.4GHz ATN frequency hopping technology from FMS. Designed to be sleek, passionate and powerful for entry level enthusiasts.

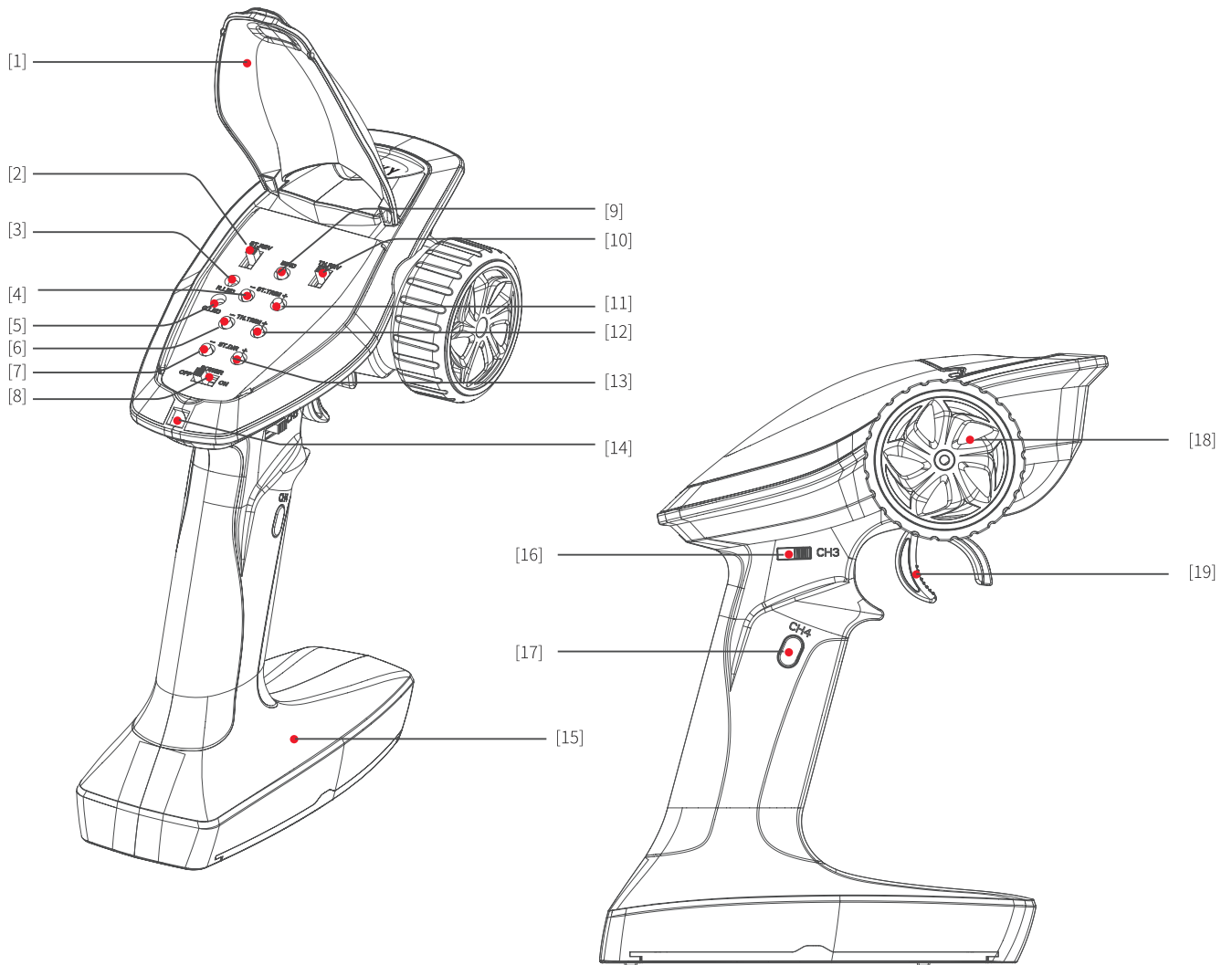







[1]	Panel Flip Cover	[11]	Steering Trim (ST.TRIM +)
[2]	Steering Reverse Switch (ST.REV)	[12]	Throttle Trim (TH.TRIM +)
[3]	Power indicator LED (R. LED)	[13]	Steering D/R (ST.D / R +)
[4]	Steering Trim (ST.TRIM-)	[14]	Lanyard Eye
[5]	Status indicator green LED (G.LED)	[15]	Base, 4 * AA battery compartment
[6]	Throttle Trim (TH.TRIM-)	[16]	Three-position switch (CH3)
[7]	Steering D/R (ST.D / R-)	[17]	Button (CH4)
[8]	Power Switch	[18]	Wheel Angle, the maximum rotation of the steering wheel is 35 degrees from center to left or right (CH1)
[9]	Bind Button (BIND)	[19]	Throttle trigger, has a total throw of 12 degrees, 12.5 degrees for backward (CH2)
[10]	Throttle Reverse (TH.REV)		

Getting Started

Before operation, install the battery and connect the system as instructed below.

★ Transmitter Battery Installation

 Danger	Only use specified battery (X4 AA batteries).
 Danger	Do not open, disassemble, or attempt to repair the battery.
 Danger	Do not crush/puncture the battery, or short the external contacts.
 Danger	Do not expose to excessive heat or liquids.
 Danger	Do not drop the battery or expose to strong shocks or vibrations.
 Danger	Always store the battery in a cool, dry place.
 Danger	Do not use the battery if damaged.

Battery Type: AA

Battery Installation:

1. Open the battery compartment cover.
2. Insert 4 fully-charged AA batteries into the compartment. Make sure that the battery makes good contact with the battery compartment's contacts.
3. Replace battery compartment cover.

Low battery alarm: When the battery is lower than 4.2v, the G.LED on the panel will flash slowly.

Instructions



After setting up, follow the instructions below to operate the system.

1、 Power On

Follow the steps below to turn on the transmitter:

1. Check to make sure that that battery is fully charged and installed correctly.
2. Toggle the switch to the [ON] position. When active the R.LED will be lit.
3. Connect the receiver to power.

For safety always power on the transmitter before the receiver.

 Note	Operate with caution in order to avoid damage or injury.
 Note	Make sure that the throttle is at its lowest position and the switches are set to their up position.

2、 Binding(The transmitter and receiver have already been bound at the factory)

However if the receiver needs to be replaced or additional receivers bound follow these steps:

1. Turn on the transmitter while holding the bind button to enter bind mode. G.LED will start flashing quickly: **Once in bind mode release the bind button.**
2. The receiver will enter bind mode atomically when powered on.
3. Once binding is successful the receiver' s LED will flash slowly and the transmitter' s LED will remain solid after being rebooted.

Note: When binding, put the transmitter into bind mode first, then the receiver.

- Applicable to the FS-G4P transmitter and the FR-R4P receiver. Different receivers have different bind procedures. For more information visit the FMS website for manuals and other related information.
- Product information is updated regularly, please visit our website for more information.

3、 Stick Calibration(This function is used to set the neutral position for throttle and wheel)

Every transmitter is calibrated before leaving the factory, however if recalibration is required, please follow these steps:

1. Turn and hold the wheel as far clockwise as it will turn, hold the throttle all the way forward, then turn on the transmitter in calibration mode.
 - The R.LED and G.LED will flash twice.
2. Calibrate wheel: Turn the wheel completely clockwise, then completely counterclockwise.
 - When calibration is completed the R.LED will be off.
3. Trigger calibration: Pull the trigger back then forward as far as it will go.
 - When calibration is completed the G.LED will be off.
4. Once calibration is complete press the bind key to save and exit.

4、Power Off

Follow the steps below to turn off the system:

- 1.Disconnect the receiver power.
- 2.Toggle the transmitter's power switch to the off position.

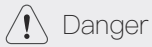

Danger

Make sure to disconnect the receiver power before turning off the transmitter. Failure to do so may lead to damage or serious injury.

System Functions

This section focuses on the functions and how to use them.

1、Channel Description

The transmitter outputs a total of 4 channels, which are allocated as follows:

- | | |
|-------------------------------|--------------------------|
| 1. CH1: Steering Wheel | 2. CH2: Throttle Trigger |
| 3. CH3: Three-position Switch | 4. CH4: Reset Button |

Note: By default the output of CH4 is 1000us, after which pressing the button will toggle between 1000 and 2000us.

2、Channel Reverse

This function is used to adjust each channels direction of movement in relation to it's input.

The ST.REV / TH.REV switches are the reverse buttons for CH1 and CH2. If the switch is up it indicates reverse, and the down indicates normal.

3、Trims

The ST.TRIM is the trims for CH1 (steering),and can be multiplexed as Trims of CH3 and CH4.

For multiplexing switching mode, see [5.5 Mode Switching].TH.TRIM is the trims for CH2(throttle).

Adjustment range: -120us- + 120us, each step is 4us;

ST.TRIM + / TH.TRIM +: increase adjustment step;

ST.TRIM- / TH.TRIM-: Decrease adjustment step.

LED Indicator:

When using the trim keys the G.LED will flash slowly on short presses and quickly on long presses.

When the fine adjustment value is at the midpoint, the G.LED will flash twice slowly.

When the fine adjustment value is at both ends (+ 120us / -120us), the trim adjustment is at its maximum and as such G.LED will not flash(if the fine adjustment value has been adjusted to + 120us, then press ST.TRIM + / TH.TRIM + key is invalid and G.LED has Instructions)

4、D/R

ST.D / R is for servo travel adjustment, which can be multiplexed as CH2 (throttle), CH3, CH4 servo travel adjustment, see [5.5 Mode Switch] for multiplex switching mode;

Adjustment range: 0–120%(the default is 100%), the step is 5%.

ST.D / R +: increase servo travel;

ST.D / R -: decrease servo travel.

LED Indicator:

When using the trim keys the G.LED will flash slowly on short presses and quickly on long presses.

When the ratio value is at both ends (0/120%), the ST.D / R button is at its maximum and as such G.LED will not flash (if the ratio value has been adjusted to 120%, then press ST.D/R+ key is invalid and G.LED has Instructions)

5、Mode switching

This function is for reusing the ST.TRIM and ST.D / R buttons for different channels (see [5.3Trims], [5.4 D/R]).

Function setting:

Under normal power-on, quickly press the Bind button twice (within 1 Sec) to cycle through modes 1, 2, 3, and 4. The default setting when powering on is mode 1.

Mode 1: G.LED flashes slowly once, ST.TRIM is CH1 fine adjustment, ST.D / R is servo travel adjustment.

Mode 2: G.LED flashes twice slowly, ST.TRIM is CH1 fine adjustment, ST.D / R is CH2 servo travel adjustment.

Mode 3: G.LED flashes three times slowly, ST.TRIM is CH3 fine adjustment, ST.D / R is CH3 servo travel adjustment.

Mode 4: G.LED flashes slowly four times, ST.TRIM is CH4 fine adjustment, ST.D / R is CH4 servo travel adjustment.

6、Failsafe

This function dictates what the receiver will do in the event that it loses signal from the transmitter, this includes servo position etc.

Setup:

1. Turn on the transmitter and make sure it is connected to the receiver.
2. Hold the control surface at the desired failsafe position.
3. Press and hold the bind button for 3 seconds, if the G.LED starts flashing every 2 seconds then setup has been successful.

Failsafe is now set and will default to these values when the receiver loses signal.

Note : The fail-safe function has no default set at the factory and as such must be set manually.If no failsafe setting has been set, then the receiver will not output anything when signal is lost.

7、Beginner Mode

Beginner mode is designed for people new to the hobby.In this mode the throttle will be limited to 50 percent, The channel range defaults to 1250~1500~1750us.

Setup:

To switch between beginner and normal modes press and hold the channel 4 button as the transmitter is turned on.

Note : By default, the system is set to normal mode. The GLED will flash slowly for 3 seconds during power on if the system is set to beginner mode.

Instructions

1、 Transmitter specification(FS-G4P)

Product Model	FS-G4P
Channels	4
Model Type	Car, Boat
RF	2.4GHz
RF Power	<20dBm
2.4GHz Protocol	ANT
Distance	>300m(ground)
Channel Resolution	1024
Battery	6V DC 1.5AA*4
Charging Interface	NO
Life time	According to battery type
Low Voltage Warning	<4.2V
Antenna Type	Built-in single antenna
Data Interface	No
Temperature Range	-10°C ~ +60°C
Humidity Range	20-95%
Online Update	No
Color	Black
Size	160*193*97mm
Weight	220g
Certification	CE, FCC ID:N4ZG4P00

Throttle stick position

Neutral point

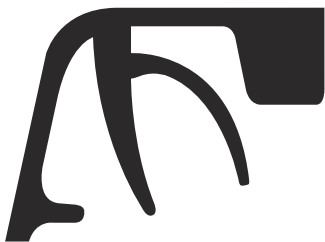

Top point of forward direction

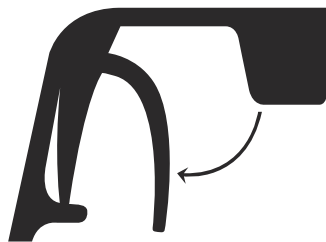

Top point of backward direction



Model		WP-1040-BRUSHED WP-1040-BRUSHED-Crawler& Boat *
Cont. / Burst Current		Forward: 40A / 180A Backward: 20A / 90A
Input		2-3S Lipo, 5-9 Cells NiMH
Cars Applicable		1:10 on-road, off-road Buggy, Truggy, SCT 1:10 Crawler, Tank & Boat
Motor Limit	2S Lipo or 5-6 cells NiMH	540 or 550 size motor $\geq 12T$ or RPM < 30000 @7.2V
	3S Lipo or 7-9 cells NiMH	540 or 550 size motor $\geq 18T$ or RPM < 20000 @7.2V
Resistance		Fwd: 0.002 Ohm, Bwd: 0.004 Ohm
Built-in BEC		2A/6V (Linear mode BEC)
Dimension & Weight		WP-1040-BRUSHED: 46.5*34*28.5, 65g WP-1040-BRUSHED-CRAWLER: 46.5*34*28.5, 70g

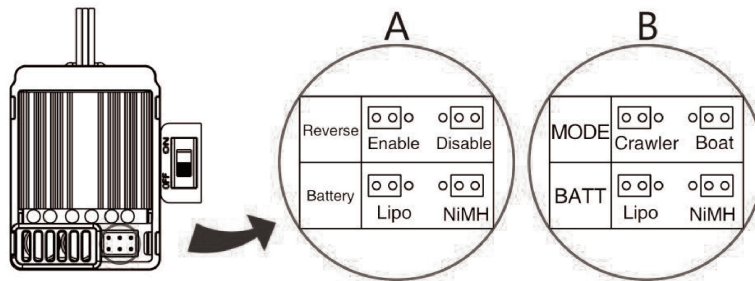

A:WP-1040-BRUSHED

B:WP-1040-BRUSHED-CRAWLER & BOAT

Trouble	Possible Reason	Solution
After power on, motor can't work, no sound is emitted, and LED is off.	The ESC doesn't get its working voltage; Connections between battery pack and ESC are broken.	Check the battery wires connection or replace the defective connectors.
	Switch is damaged.	Replace the switch.
After power on, motor can't work; red LED blinks.	Throttle signal is abnormal.	Check the throttle wire connection; make sure it is plugged into the throttle channel of the receiver.
	Automatic throttle range calibration is failed.	Set the "TRIM" of throttle channel to 0 or turn the knob to its neutral position.
The car runs backward while giving throttle. (The motor runs in the opposite direction.)	The wire connections between ESC and the motor need to be changed.	Swap two wire connections between the ESC and the motor.
The car can't go backward.	The jumper position is wrong.	Check the jumper and plug it to the correct position.
	The neutral point of throttle channel is changed or drifted.	Set the "TRIM" of throttle channel to 0 or turn the knob to its neutral position.
The car can't go forward, but can go backward.	The direction of throttle channel is not correct.	Reset the direction of throttle channel from original "NOR" to "REV", or from original "REV" to "NOR".
The motor doesn't work, but the LED in the ESC works normally.	The connections between motor and ESC are broken.	Check the connections and replace the defective connectors.
	Motor is damaged.	Replace the motor.
The motor suddenly stops running while in working state.	The throttle signal is lost.	Check the transmitter and the receiver. Check the throttle wire connection.
	Low voltage cut-off protection or Over-heat cut-off protection has been activated.	Replace the battery pack, or cool down the ESC.
The car cannot get top speed and the red LED doesn't solid on at full throttle.	Some setting in the transmitter are incorrect.	Check the settings. Set D/R, EPA, ATL to 100% or turn the knobs to maximum value. Set TRIM to 0 or turn the knob to its neutral position.
Motor is cogging when accelerated quickly.	The battery has limited discharge ability.	Use battery with better discharge ability.
	Motor RPM is too high, the gear ratio is too aggressive.	Use motor with lower RPM, or use smaller pinion to get softer gear ratio.
	Something wrong in the driving system of the car.	Check the driving system of the car.

Operating the vehicle

Step 1: turn on the transmitter, the headlamp of the transmitter will flash and enter the frequency matching mode.

Step 2: turn on the receiver switch, the headlight will flash and enter the frequency matching mode.

Step 3: when the transmitter and receiver are successful in frequency up, the front lights of the transmitter will be on for a long time, and the front lights of the vehicle will be off.

Assembling

Install the rearview mirrors and the top bow assembly as showned below.

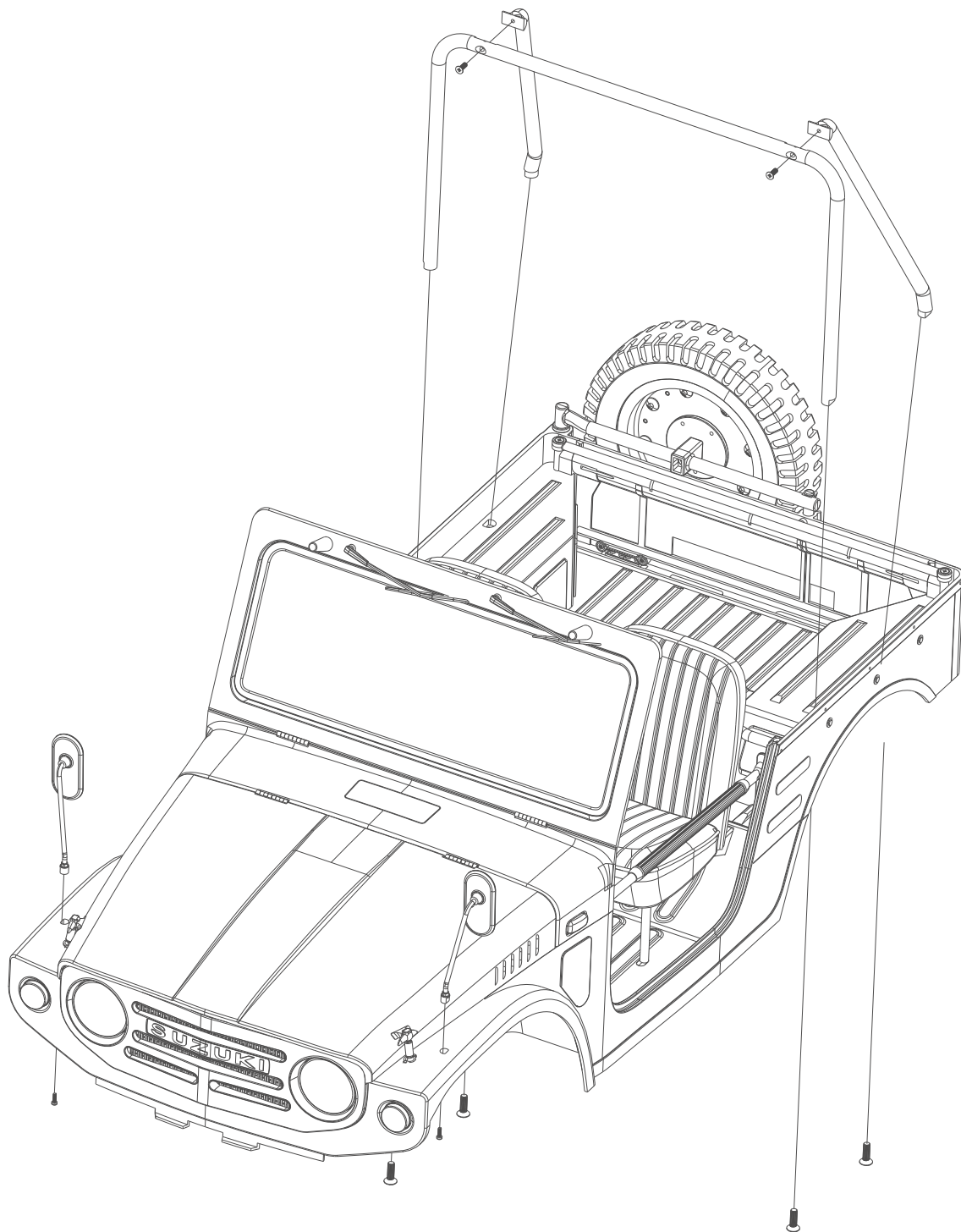

Setting the Gear Mesh

The gear mesh is the clearance between the pinion and spur gears in your vehicle. If the motor or gearing components are replaced, check that the gears are not meshing too tightly as this may cause premature wear.

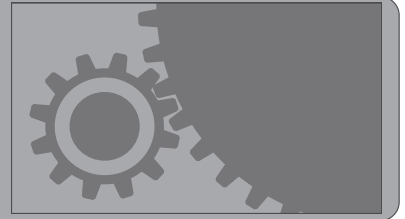

Charging the Battery

- Always charge LiPo batteries on non-flammable, heat-resistant surfaces.
- Always use a LiPo-safe bag or container while charging. Do not allow LiPo cells to overheat at any time. Cells which reach greater than 140 Fahrenheit (60°C) will usually become damaged and will catch fire.
- Do not charge the LiPo pack while it is still in the model. Never charge or store battery packs in a vehicle.
- Do not discharge LiPo; doing so will damage the battery.
- Do not expose LiPo cell to water or moisture at any time.
- Do not store battery near open flame or heater.
- Do not assemble LiPo cells or pre-assembled packs together with other LiPo cells or packs.
- Always store LiPo battery in a secure location away from children.
- Always remove the LiPo battery if model is involved in any kind of crash.
- Carefully inspect the battery and connectors for even the smallest damage.
- CAUTION: Cells may become hot after usage. Allow the pack to cool to room temperature prior to recharging.
- Do not allow the electrolyte to get into eyes or on skin. Wash affected areas immediately if they if they come into contact with electrolyte. Do not alter or modify connectors or wires of a LiPo battery pack.
- Always inspect the condition of the battery before charging and operating.
- Do not short circuit the LiPo battery.
- Do not have contact with a leaky/damaged battery directly.
- Do not charge battery out of recommended temperature range (0°C–45°C).

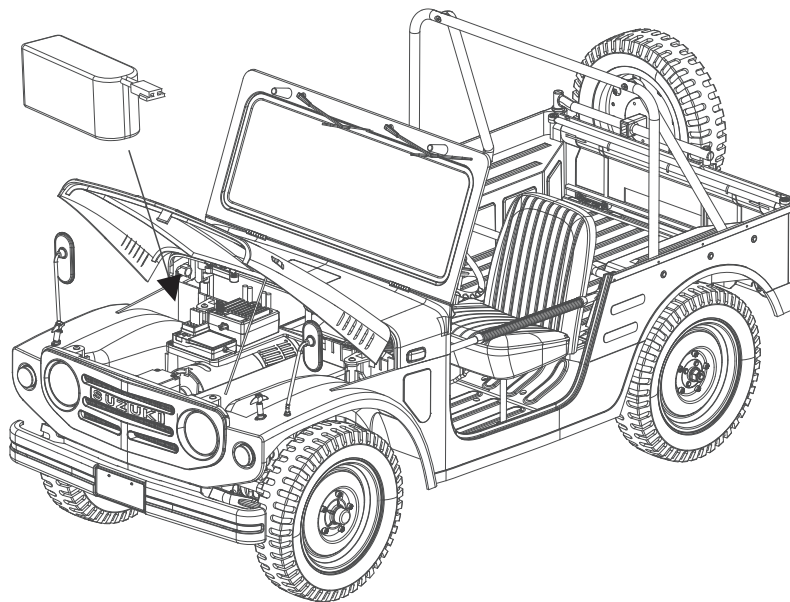
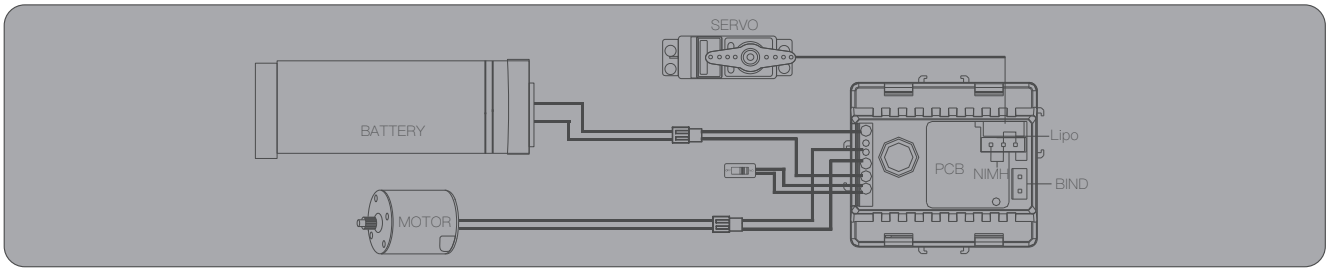

<p>! NOTE</p>	<p>1.If it is not in use for a long time, unplug and take off the battery to prevent battery leakage 2.Do not open, disassemble, or attempt to repair the battery.</p>
---------------	---

CE Warning

The antenna(s) used for this transmitter must be installed to provide a separation distance of at least 20 cm from all persons and must not be co-located or operating in conjunction with any other transmitter. End-users and installers must be provided with antenna installation instructions and transmitter operating conditions for satisfying RF exposure compliance.

Appendix 1 FCC Statement

FCC ID: 2AUBX-HT-TX02

This equipment has been tested and found to comply with the limits for a Class B digital device pursuant to part 15 of the FCC rules. These limits are designed to provide reasonable protection against harmful interference in a residential installation. This equipment generates, uses and can radiate radio frequency energy and, if not installed and used in accordance with the instructions, may cause harmful interference to radio communications. However, there is no guarantee that interference will not occur in a particular installation. If this equipment does cause harmful interference to radio or television reception, which can be determined by turning the equipment off and on, the user is encouraged to try to correct the interference by one or more of the following measures:

- Reorient or relocate the receiving antenna.
- Increase the separation between the equipment and receiver.
- Connect the equipment into an outlet on a circuit different from that to which the receiver is connected.
- Consult the dealer or an experienced radio/TV technician for help.

To assure continued compliance, any changes or modifications not expressly approved by the party responsible for compliance could void the user's authority to operate this equipment.

This equipment complies with Part 15 of the FCC Rules. Operation is subject to the following two conditions:

- (1) This device may not cause harmful interference.
- (2) This device must accept any interference received, including interference that may cause undesired operation.

Caution!

The manufacturer is not responsible for any radio or TV interference caused by unauthorized modifications to this equipment. Such modifications could void the user authority to operate the equipment.

1. The antenna(s) used for this transmitter must be installed to provide a separation distance of at least 20 cm from all persons and must not be co-located or operating in conjunction with any other transmitter. End-users and installers must be provided with antenna installation instructions and transmitter operating conditions for satisfying RF exposure compliance.
2. Move all your channels to the desired position.
3. Select [All channels] and then [Yes] in the confirmation box.

目录

产品介绍	16
发射机概览	16
油门扳机位置	22
车辆操作	25
车辆安装	25
齿轮齿盒设置	26
电池充电	26
轮胎组	27
车窗组	27
座椅组	28
转向拉杆组	28
方向盘舵机组	29
前桥组	29
后桥组	30
中传动牙箱	30
传动轴组	31
驱动牙箱	31
避振组	32
车壳半成品	32
车壳成品	33
配件明细表一	36
配件明细表二	37

产品介绍

吉姆尼，一款传奇车型，它的出现打破了人们对于硬派越野车的固有认知。凭借着小排量、小尺寸、低价格，以及独树一帜的市场定位，精准地填补了市场空白，并成为了众多越野爱好者承载梦想的可靠工具。

吉姆尼的前身是希望汽车的希望之星ON型4WD，1968年出售给铃木汽车。1970年经过铃木改进，搭载359cc两冲程直列双缸，车重仅600kg的LJ10问世。

FMS获得铃木公司授权打造的第一代吉姆尼LJ10和真车一样，采用金属大梁，非承载式底盘，前后钢板弹簧悬挂，万向节传动。比例则是完全精准的1/6，座椅采用软胶包裹，模拟真实座椅的柔软度和塌陷效果，搭配1/6人偶，呈现完美坐姿和行驶姿态。

电机、电调、接收机和电池全部整合到引擎盖下方，打开引擎盖即可看到所有设备，换电、设定、维护更加方便。

风挡可以向前放倒，后视镜采用真镜片制作，方向盘联动，两侧车门位置的安全杆也可以像真车一样放倒。

方向盘，微缩影仪表盘和机械按钮、手动排档、脚踏板组等内饰都精细做出像真件。

全尺寸备胎，备胎架向右侧开启后，尾门可以放倒，后斗空间得以完全呈现，搭载各类仿真零件十分方便，演出不同风格也能轻松实现。

黑色防滚架为可拆卸结构，方便升级改造不同材质，不同风格的防滚架。

灯光方面，车头灯默认常亮，从接收机取电，前后转向灯和尾灯预留灯珠位置，方便升级灯光系统。

发射机概览

FS-G4P是一款使用富斯最新自主研发的2.4GHz ANT蚂蚁版自动跳频数字系统的简版4通道发射机，外观采用跑车元素彰显速度、激情和力量，该款发射机还具备初学者模式方便入门玩家使用。

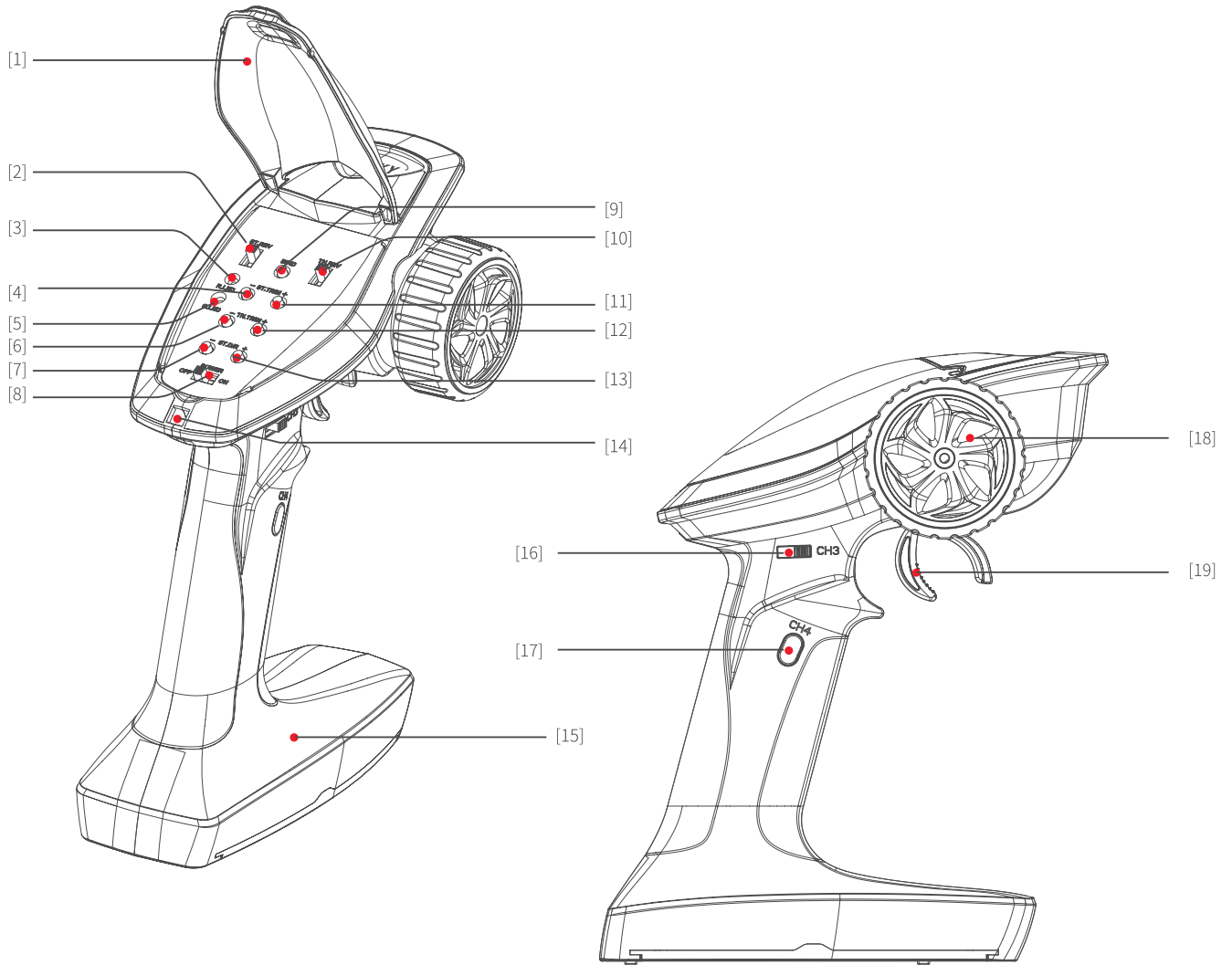







[1]	功能面板保护盖	[11]	方向微调按键 (ST.TRIM+)
[2]	方向倒置开关 (ST.REV)	[12]	油门微调按键 (TH.TRIM+)
[3]	电源指示灯红色LED (R.LED)	[13]	方向比例调节按键 (ST.D/R+)
[4]	方向微调按键 (ST.TRIM-)	[14]	挂绳孔
[5]	状态指示灯绿色LED (G.LED)	[15]	底座, 4*AA电池仓
[6]	油门微调按键 (TH.TRIM-)	[16]	三档拨动开关 (CH3)
[7]	方向比例调节按键 (ST.D/R-)	[17]	按键开关 (CH4)
[8]	电源开关	[18]	方向手轮, 左右各35度 (CH1)
[9]	对码按键 (BIND)	[19]	油门扣机, 前25度后12.5度 (CH2)
[10]	油门倒置开关 (TH.REV)		

使用前准备

开始操作前，请按照本章的顺序和指引安装电池、连接设备。

★发射机电池安装

 危险	仅使用厂家指定的电池。
 危险	请勿打开、拆卸或自行维修电池。
 危险	请勿挤压、刺穿或接触电池的金属端子。
 危险	请勿将电池置于高温环境或液体中。
 危险	如果不按照说明方法操作，可能导致操作者或他人遭受较大伤害。
 危险	请将电池存放在干燥阴凉的环境中。
 危险	如果电池损坏，请立即停止使用。

电池类型使用: AA电池

请按照以下步骤安装发射机电池:

- 1.打开电池仓盖。
- 2.将4颗电量充足的AA电池装入电池仓内，确保电池上的金属端子与电池仓内的金属端子接触。
- 3.盖好电池仓盖。

低电量报警:当电量低于4.2v时，面板上的G.LED慢闪报警提示。

操作指引

准备操作完成后, 您可以按照本章指引开始使用本产品。

1、开机

请按照以下步骤进行开机:

1. 检查系统状态, 确保 : 电池电量充足且安装正确。
2. 将开关拨到 [On] 位置, R.LED 灯常亮。
3. 连接接收机电源。

注意 : 为保障模型及人员安全, 使用时请先打开发射机再给接收机上电。

 警告	此时系统已启动, 请谨慎操作, 否则可能导致产品损坏或人员伤亡。
---	----------------------------------

 警告	为了您的安全请将发射机开关和油门打到安全位置。
---	-------------------------

2、对码 (发射机和接收机在出厂前已对码成功。)

如需更换其他的发射机或接收机, 请按照如下步骤进行对码:

1. 如需更换其他的发射机或接收机, 请按照如下步骤进行对码 : 进入对码状态后松开“BIND” 键;
2. 接收机上电自动进入对码 ;
3. 对码成功接收机 LED 指示灯慢闪, 发射机关机重启接收机指示灯常亮 ;

注意 : 对码时请先将发射机进入对码状态, 再将接收机进入对码状态。

- 此对码步骤仅适用于 FS-G4P 发射机与 FS-R4P 接收机对码, 不同的接收机对码方式不同, 请进入 FMS官网查询接收机说明书或其他相关资料, 进行操作。
- 由于产品处于不断更新状态, 请进入 FMS官网查询最新的发射机与接收机兼容表单。

3、遥感校准 (该功能可以用于方向手轮和油门扳机的中位角度修正。)

发射机在出厂前已校准完成, 如需要重新校准, 请按照以下步骤执行:

1. 同步将手轮顺时针打到最大、扣机往前推到底并开机, 进入校准模式功能 ;
 - R.LED和G.LED二闪一灭
2. 手轮校准: 操作手轮顺时针和逆时针转到最大最小 ;
 - R.LED红色常亮
3. 扣机校准: 往前往后推到最大最小 ;
 - G.LED绿色常亮
4. 校准完成后按“BIND” 键退出并保存数据。

4. 关机

请按照以下步骤进行关机:

1. 断开接收机电源。
2. 将开关拨到[OFF]位置, 使发射机关闭。



危险

关闭时, 请务必先关闭接收机电源, 再关闭发射机, 否则可能导致模型损坏、人员受伤。

系统功能

此章节主要介绍系统各项功能操作。

1、通道说明

该发射机共输出4个通道, 分配如下:

1. CH1: 方向手轮
2. CH2: 油门]扣机
3. CH3: 三档开关
4. CH4: 复位按键

注意: CH4 按键开机默认输出 1000us, 按压操作一下通道值翻转 - 次, 数值在 1000us/2000us 之间互相切换。

2、通道反向 (该功能用于调整舵机或马达的动作方向。)

按键ST.REV/TH.REV分别为CH1、CH2通道反向按键, 开关上拨表示反向, 下拨表示正常。

3、微调

按键ST.TRIM和TH.TRIM分别为CH1 (方向)和CH2 (油门)的微调按键。

调节范围: $-120\mu\text{s}$ ~ $+120\mu\text{s}$, 微调步进为 $4\mu\text{s}$;

ST.TRIM+/TH.TRIM+:增大微调值;

ST.TRIM-/TH.TRIM-:减少微调值。

LED指示情况:

操作- -次微调键G.LED闪烁- -次, 长按快闪

当微调值位于中点时G.LED慢闪2下

当微调值位于两端时($+120\mu\text{s}$ / $-120\mu\text{s}$), 微调无效且G.LED无指示(如微调值已调至 $+120\mu\text{s}$, 此时按ST.TRIM+/TH.TRIM+键无效且G.LED无指示)

4、方向比例

ST.D/R为CH1方向比例调节,默认为最大100%,步进为5%

调节范围:0-100%;

ST.D/R+:增加比例;

ST.D/R-:较小比例。

LED指示情况:

操作一次按键 G.LED 闪烁一次,长按快闪

当比例值位于两端时(0/100%),按键无效且 G.LED 无指示(如比例值已调至 100%,此时按 ST.D/R+ 键无效且 G.LED 无指示)

5、失控保护

此功能用于当接收机无法正常收到发射机的信号时,对应通道舵机移动至预先设定的位置,保护模型和操作人员的安

全。

功能设置:

发射机开机正常通讯状态下,将需要设置的通道保持在需要设定的失控保护值位置保持不动,同时长按对码键(BIND) 3S, G.LED 闪烁 2S 表示设置成功,即当接收机无法接收信号后,将按照设定的失控值输出。

注意:失控保护出厂默认无任何设置,无设置时失控接收机无有效信号输出。

6、初学者模式

初学者模式比较适合入门级玩家,通过对油门幅度的控制来提高操作的安全性。

初学者模式模式油门输出仅为 50%。

功能设置:

按住 CH4 键开机即可实现正常模式和初学者模式互相切换,开机时 G.LED 灯慢闪表示成功进入初学者模式。

注意:出厂默认为正常模式,开机时 G.LED 灯慢闪持续 3S,代表此次进入初学者模式。

产品规格

1、发射机规格 FS-G4P

产品型号	FS-G4P
通道个数	4
适配模型	车、船
无线频率	2.4GHz
发射功率	<20dBm
无线协议	ANT
遥控距离	>300m(空旷无干扰地面距离)
通道分辨率	1024 级
电池	6V DC 1.5AA*4
充电接口	无
续航时间	依电池类型
低电压报警	<4.2V
天线类型	内置单天线
数据接口	无
温度范围	-10°C ~ +60°C
湿度范围	20-95%
在线更新	无
遥控器颜色	黑
外形尺寸	160*193*97mm
机身重量	220g
认证	CE, FCC ID:N4ZG4P00

油门扳机位置

中位



前进方向的顶端

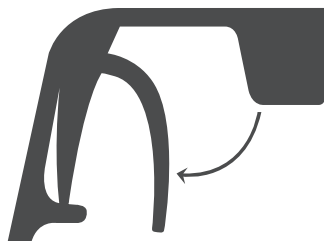

后退方向的顶端



型号		WP-1040-BRUSHED WP-1040-BRUSHED-Crawler&Boat *
正向持续/峰值电流 (10秒) 反向持续/峰值电流 (10秒)		40A / 180A 20A / 90A
支持电压范围		2-3节锂电 (Lipo) 或 5-9节镍氢 (NiMH) 电池
主要适用车型		普通版: 1/10 电房、电越、短卡、大脚、卡车 攀爬/船用版: 1/10 攀爬车、坦克及各种模型船
支持电机 T数	2节锂电 或6节镍氢	540或550尺寸电机≥12T 或RPM低于30000 @7.2V
	3节锂电 或9节镍氢	540或550尺寸电机≥18T 或RPM低于 20000 @7.2V
内阻 (单桥臂)		正转0.002欧姆, 反转0.004 欧姆
BEC输出		6V/2A (线性稳压BEC)
尺寸 (mm)		WP-1040-BRUSHED:46.5*34*28.5 WP-1040-BRUSHED-Crawler&Boat:46.5*34*28.5
重量		WP-1040-BRUSHED:65g WP-1040-BRUSHED-Crawler&Boat:70g

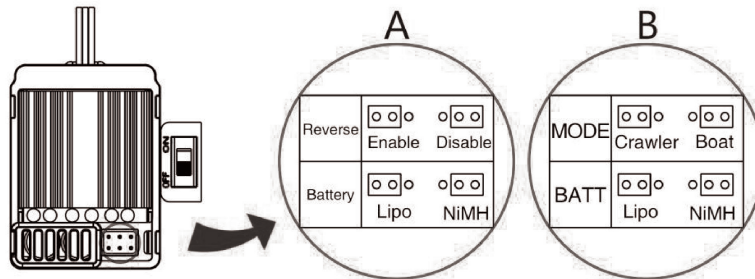

A:WP-1040-BRUSHED

B:WP-1040-BRUSHED-CRAWLER & BOAT

故障现象	可能原因	解决方法
上电后指示灯不亮，不自检，无鸣音。	1. 电调没有得到工作电源。 2. 电调开关损坏。	1. 检查电池到电调的电源输入通路是否有焊接不良情况，并重新焊好。 2. 更换电调开关。
上电后红色LED 闪烁，电机无法启动。	1. 电调油门线插反或通道插错。 2. 电调无法完成油门自检校调。	1. 将电调的油门排线按正确方向插到接收机的油门通道（Throttle, 通常为CH2）。 2. 将遥控器的油门通道的中点微调“TRIM”调为0 或相应旋钮调到中点位置。
遥控器做前进操作，车子反而倒退。	1. 遥控器油门通道方向设置错误或马达接线错误。	1. 将马达的两条线互换。 2. 将遥控器油门通道反向，从原“NOR”换为“REV”或从原“REV”换为“NOR”。
车子无法达到全速，油门打到最大，红灯不恒亮。	1. 遥控器设置错误。	1. 将遥控器油门通道的“D/R”、“EPA”、“ATL”等参数调到100%或相应旋钮调到最大位置，油门通道的中点微调“TRIM”调为0 或相应旋钮调到中点位置。
车子无法倒车。	1. 倒车选项跳线帽位置错误。 2. 油门中点偏移。	1. 将倒车选项跳线帽插入正确位置。 2. 将遥控器的油门通道的中点微调“TRIM”调为0 或相应旋钮调到中点位置。
车子正向加油不走，反向倒车却行走。	1. 遥控器油门通道方向设置错误。	1. 将遥控器油门通道反向换，从原“NOR”换为“REV”或从原“REV”换为“NOR”。
电机转动过程中，突然停转。	1. 油门信号丢失。 2. 电调进入电池低压保护或过热保护状态。	1. 检查遥控器电池电压是否过低。 2. 电调红灯闪烁表示低压或过热保护，请更换电池组或检查电调温度。
车子无法前进也无法倒车，指示灯正常。	1. 电调和马达之间的连接中断。 2. 马达损坏。	1. 检查马达和电调之间的接头，确保连接可靠。 2. 更换新马达。
电机启动时急加速，电机有卡住或停顿的现象。	1. 电池放电能力不够。 2. 电机转速过高，齿轮比搭配过于激进。 3. 车子传动系统有问题。	1. 更换放电能力强的电池。 2. 更换低速电机，或将减速比提高。 3. 检查车架传动系统是否顺畅。

车辆操作

步骤1：打开发射器，发射器前灯会闪亮，进入对频模式。

步骤2：打开接收器开关，车前灯会闪亮，进入对频模式。

步骤3：当发射器、接收器对上频成功时，发射器前灯会长亮，车前灯会关闭。

车辆安装

如图所示，安装后视镜及尾架。

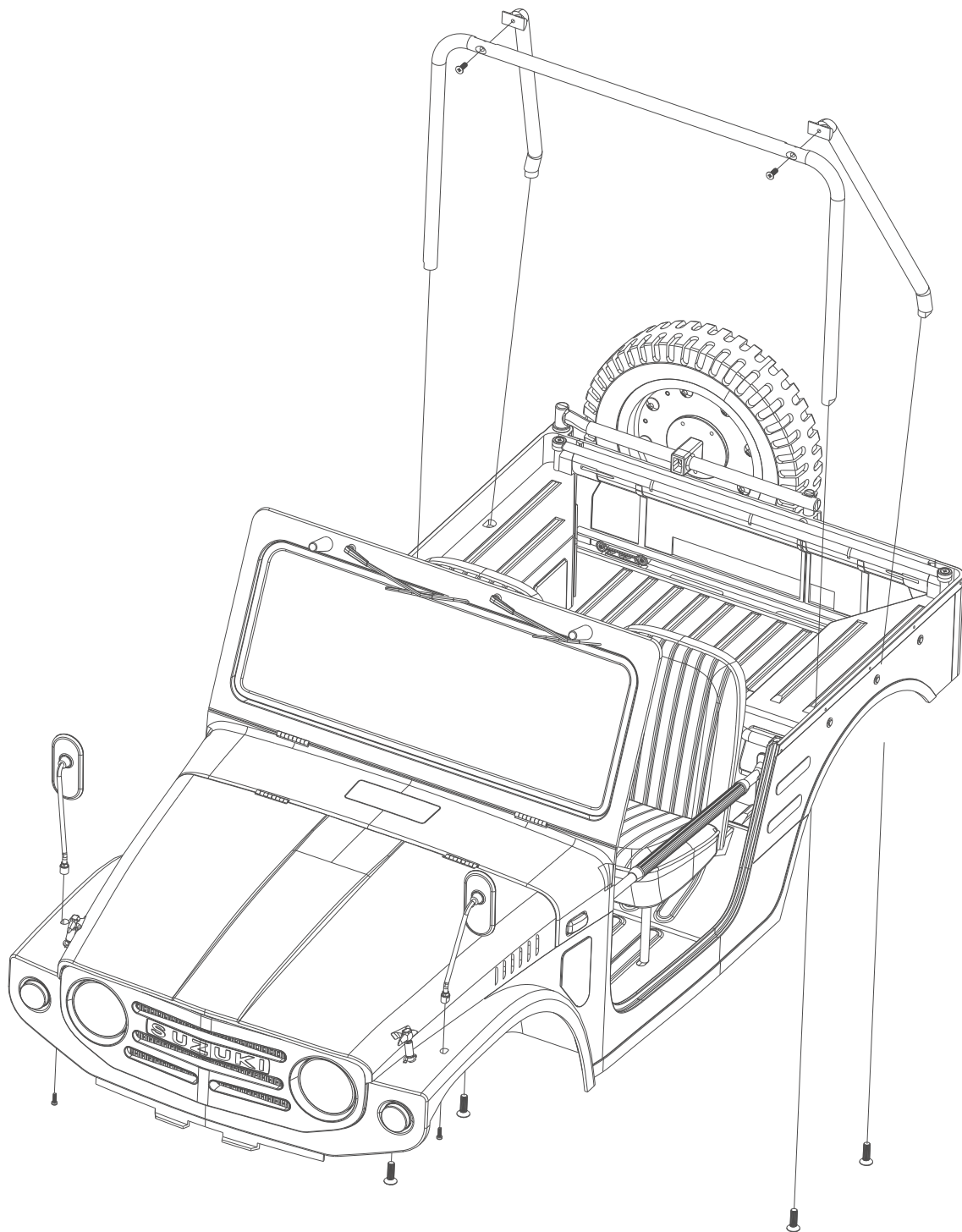

齿轮齿盒设置

齿轮啮合是模型车内小齿轮和直齿轮之间的间隙配合。如果更换电机或齿轮传动部件，请检查齿轮咬合是否过于紧密，如过于紧密，则可能导致过早出现磨损。

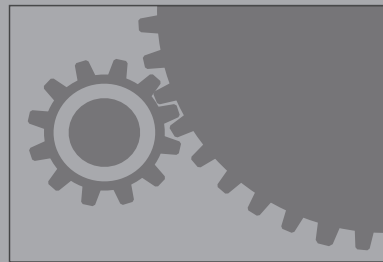

电池充电

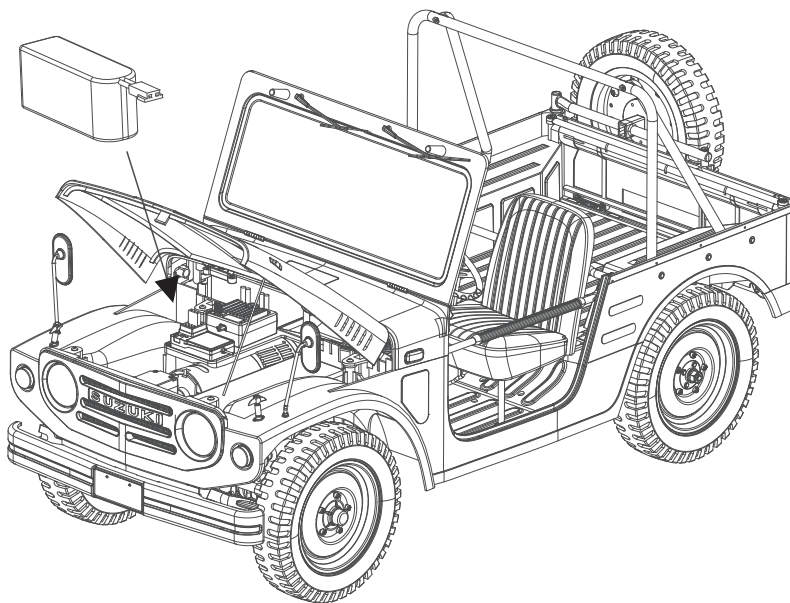

警告

1. 长期不使用时，应拔开并取出电池，以防电池漏液。
2. 请勿打开、拆卸或维修电池。

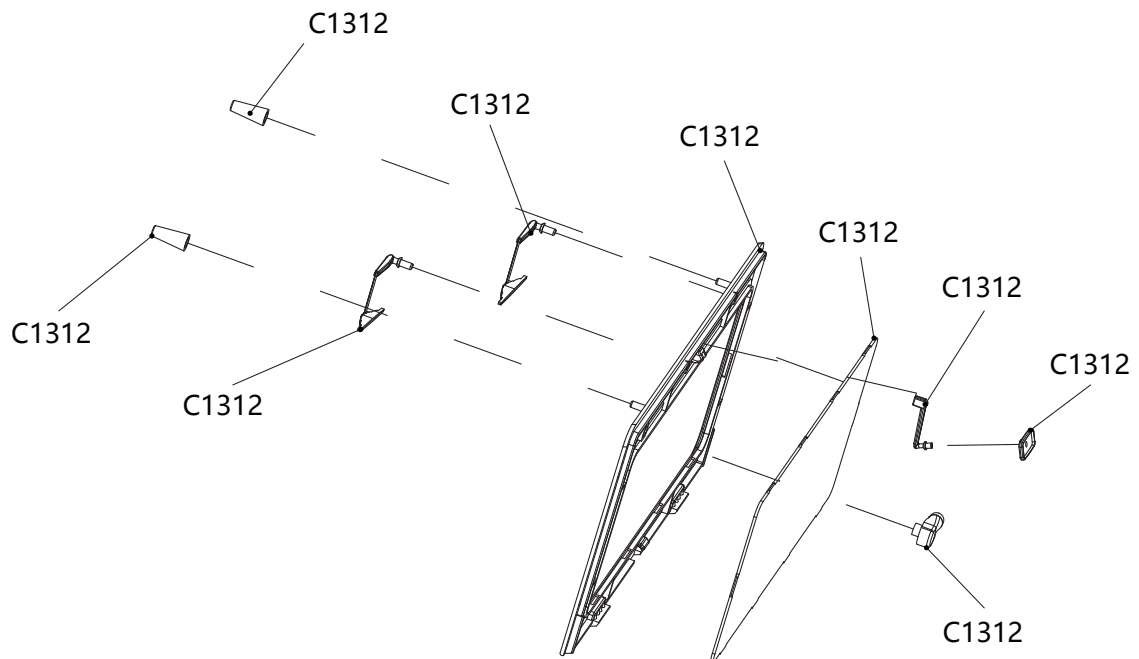
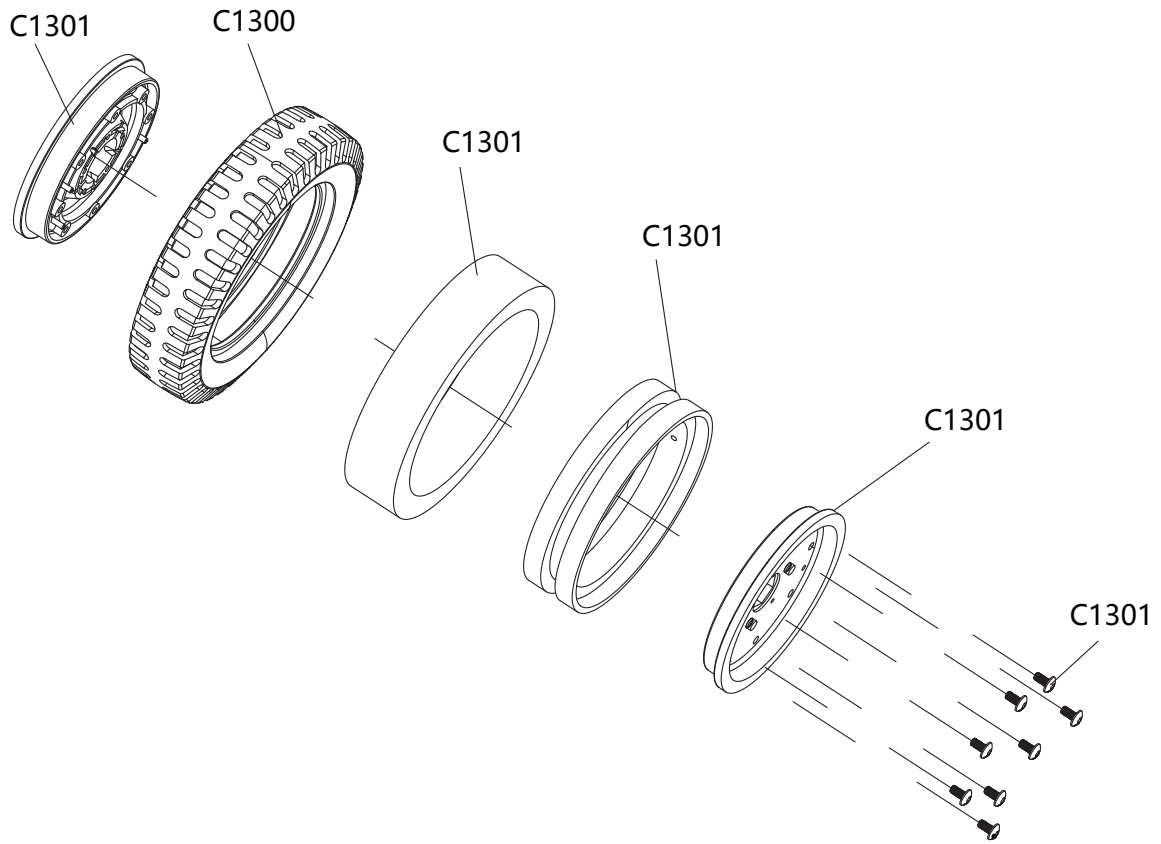

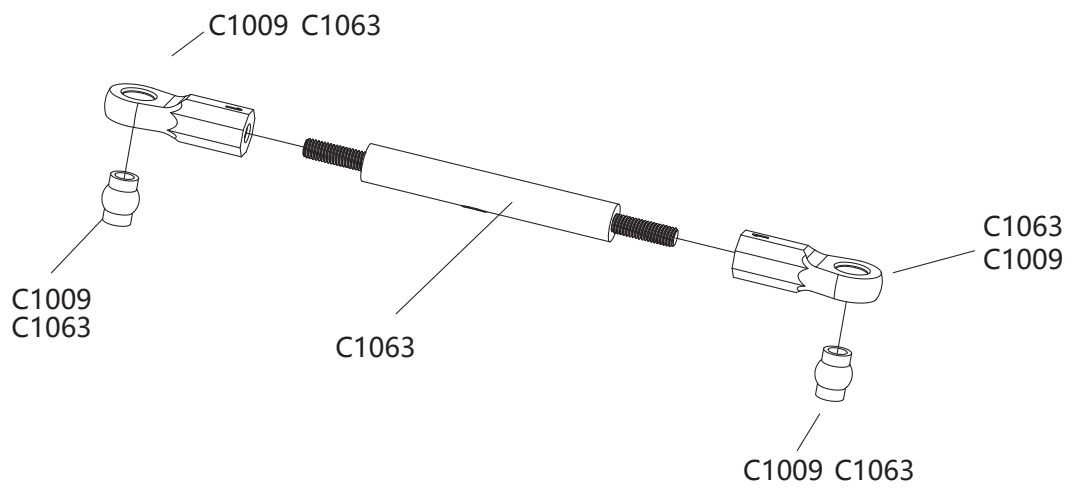
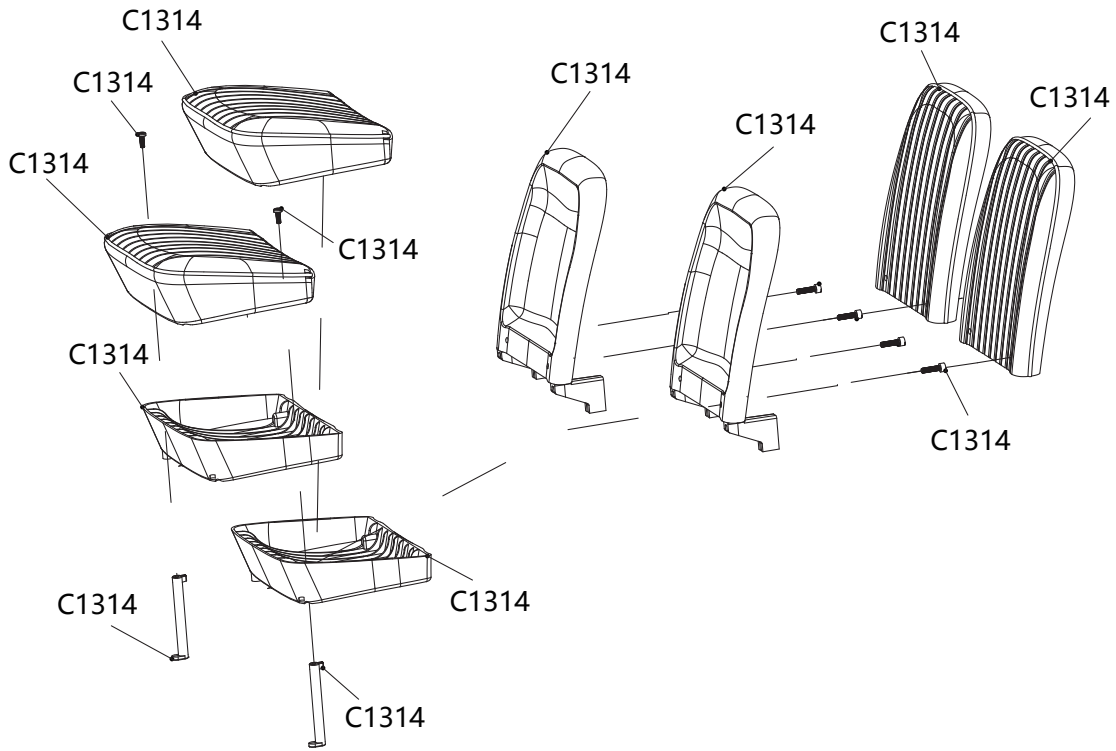

C1035

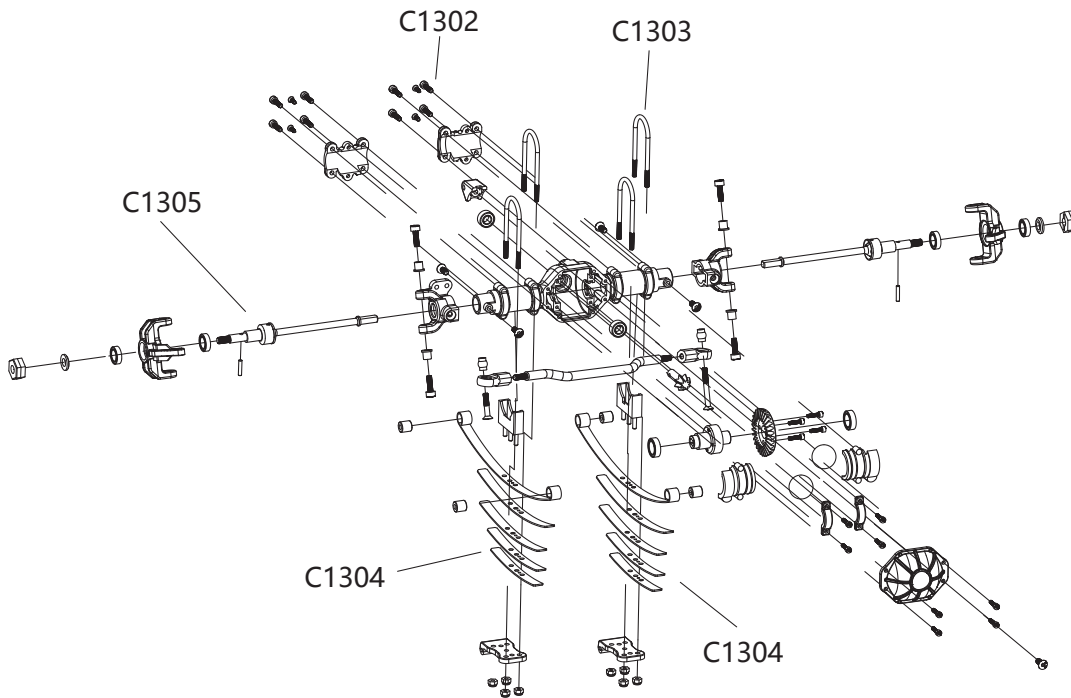
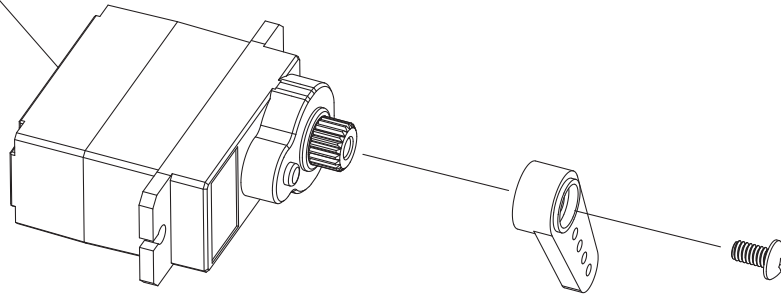

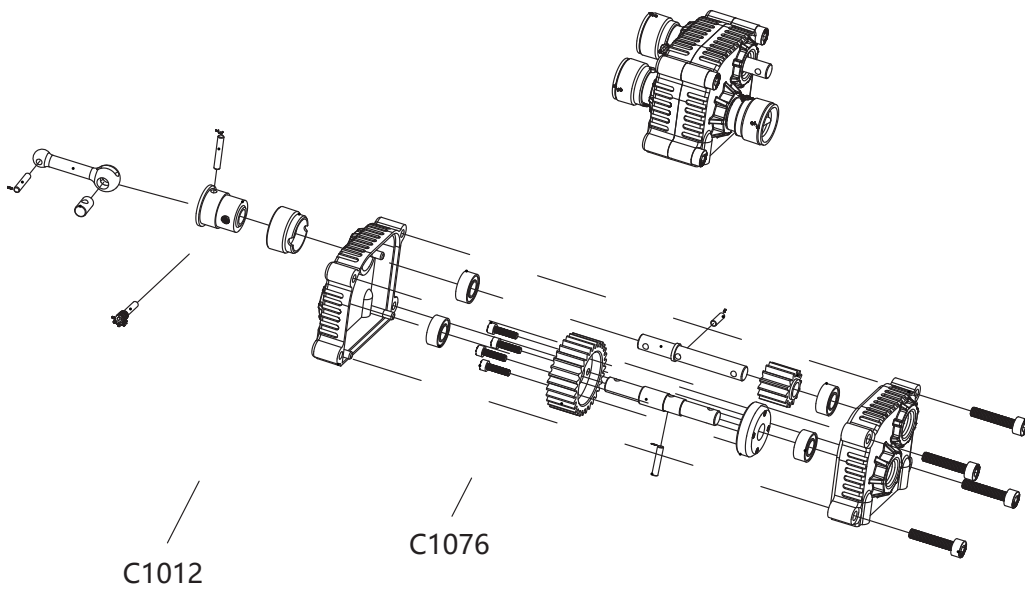
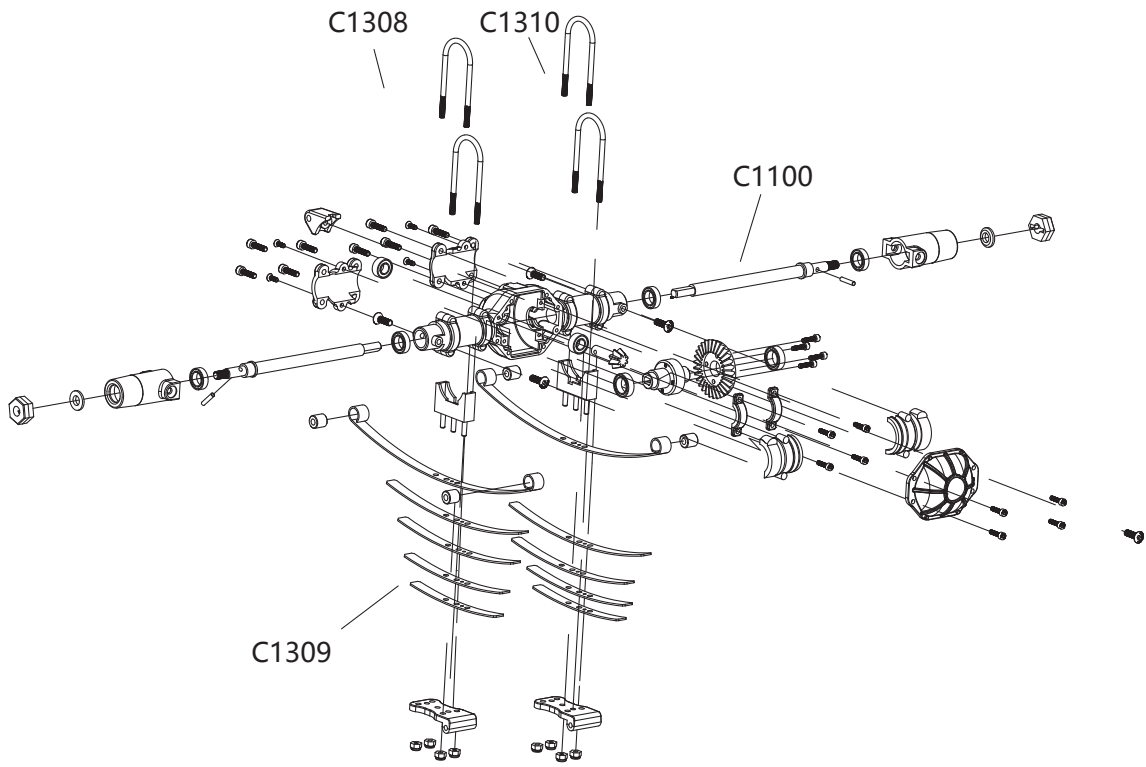

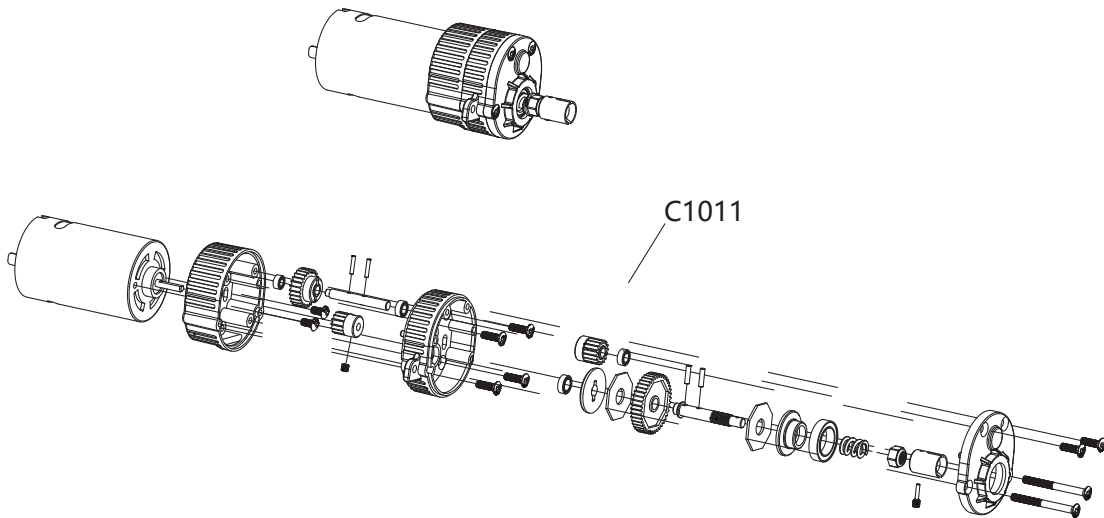
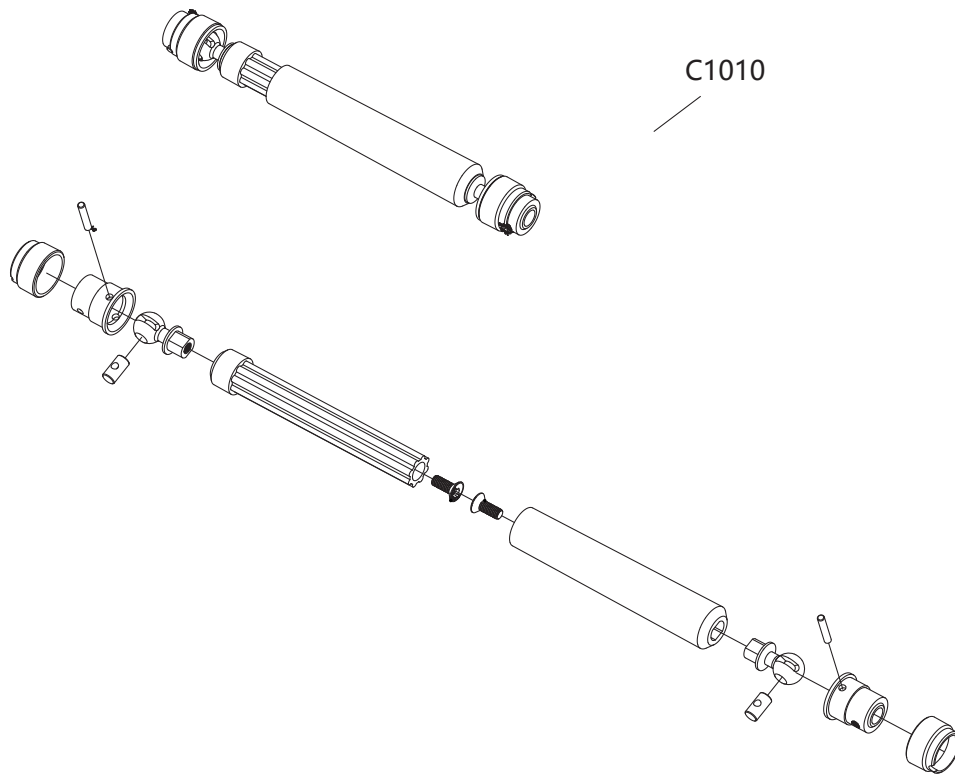

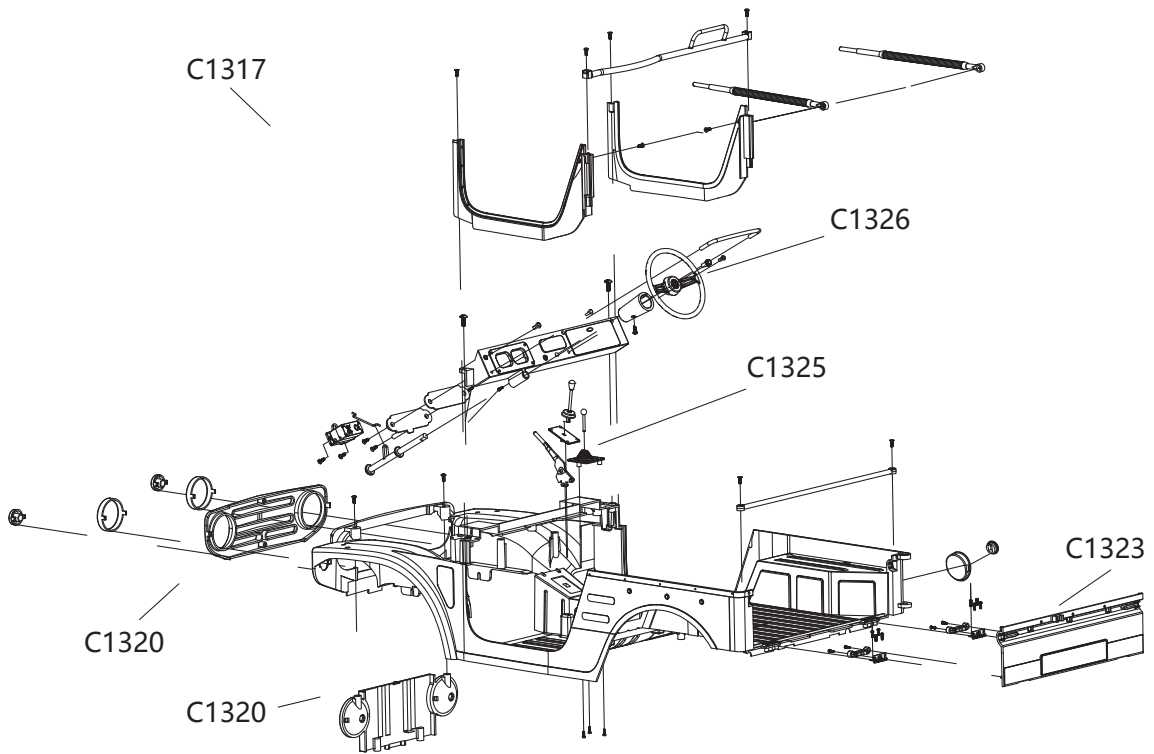
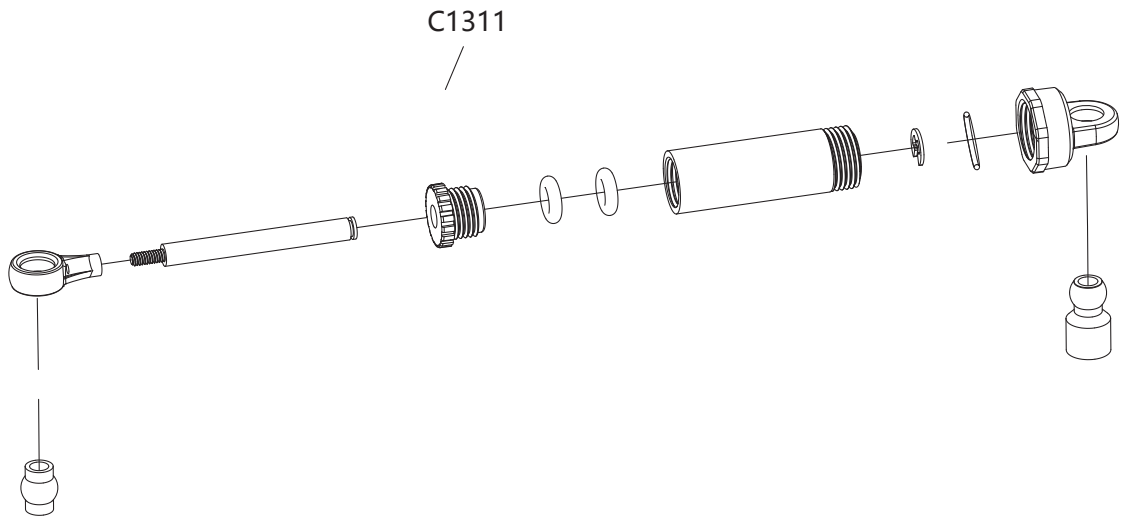

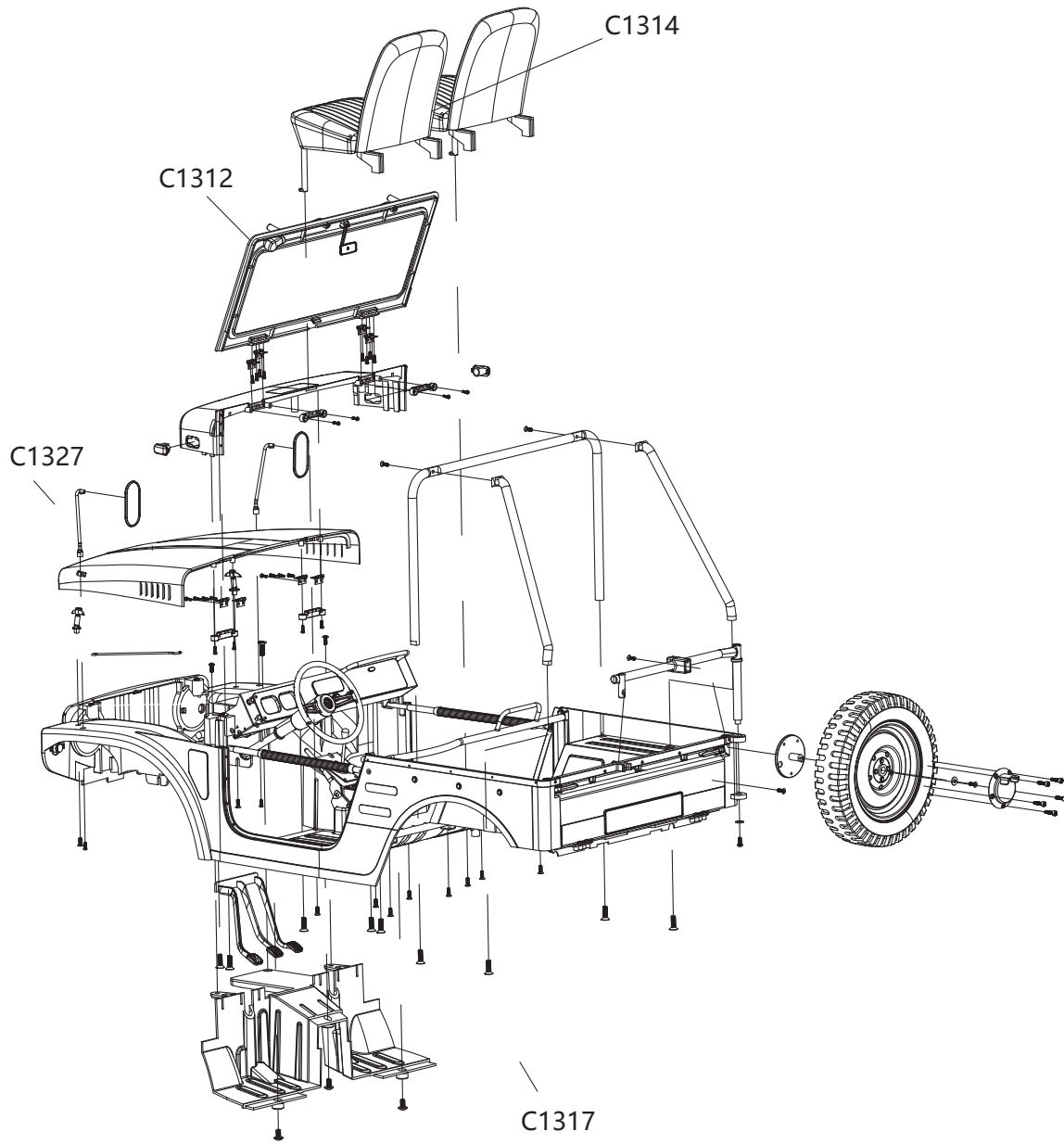

“S” for spare part

“O” for optional part

PART NUMBER	PRODUCT DESCRIPTION	S/O
C1011	MAIN GEAR BOX SET	
C1010	TRANSMISSION SHAFT ASSEMBLY	
C1012	TRANSMISSION GEAR BOX ASSEMBLY	
C1021	12mm WHEEL HEX SET	
C1300	1:6 JIMNY TYRES	
C1301	1:6 JIMNY WHEELS	
C1302	1:6 JIMNY FRONT AXLE ASSEMBLY	
C1303	1:6 JIMNY FRONT AXLE PLASTIC PARTS	
C1304	1:6 JIMNY FRONT AUTOMOBILE LEAF SPRINGS	
C1305	1:6 FRONT OUTDRIVE SHAFT ASSEMBLY	
C1016	1:6 STEERING C HUB PARTS	
C1063	1:6 STEERING LINK	
C1308	1:6 JIMNY REAR AXLE ASSEMBLY	
C1309	1:6 JIMNY REAR AUTOMOBILE LEAF SPRINGS	
C1100	1:6 Rear Wheel Shaft	
C1310	1:6 JIMNY REAR AXLE PLASTIC PARTS	
C1311	1:6 JIMNY OIL SHOCK ABSORBERS ASSEMBLY	
C1312	1:6 JIMNY WINDOW FRAME	
C1313	1:6 JIMNY WIPER SET	
C1314	1:6 JIMNY SEAT SET	
C1315	1:6 JIMNY FRONT BUMPER SET	
C1316	1:6 JIMNY REAR BUMPER SET	
C1317	1:6 JIMNY CAR BODY ASSEMBLY	
C1318	1:6 JIMNY MIRROR SET	
C1319	1:6 JIMNY WHEELS ASSEMBLY (1 Pair)	
C1320	1:6 JIMNY RADIATOR GRILLE SET	
C1321	1:6 JIMNY LENS SET	
C1322	1:6 JIMNY FUEL TANK COVER	
C1323	1:6 JIMNY REAR DOOR	
C1324	1:6 JIMNY REAR DOOR LINK	
C1325	1:6 JIMNY SHIFT BAR ARM SET	
C1326	1:6 JIMNY STEERING WHEEL SET	
C1327	1:6 JIMNY HOOD	
C1328	1:6 JIMNY HOOD LOCK	
C1329	1:6 JIMNY ROLL CAGE	
C1330	1:6 JIMNY SPARE TIRE RACK	
C1331	1:6 JIMNY HANDRAIL	
C1009	BALL CAP FOR LINKAGE & ROD	
C1020	1:6 SCREW NUT SET	
C1022	1:6 PIN LOCK SET	
C1023	1:6 BEARING SET	
C1066	1:6 SLIPPER SPRING	
C1067	1:6 SLIPPER PAD	
C1068	1:6 SPUR GEAR 42T 0.6	

“S” 为配件

“O” 为升级件

PART NUMER	PRODUCT DESCRIPTION	S/O
C1011	驱动牙箱组散件	
C1010	传动轴成品	
C1012	中传动牙箱成品	
C1021	12mm 车轮6角件	
C1300	1:6 吉姆尼轮胎	
C1301	1:6 吉姆尼车轮	
C1302	1:6 吉姆尼 前桥成品	
C1303	1:6 吉姆尼 前桥胶件	
C1304	1:6 吉姆尼 前钢板弹簧	
C1305	1:6 前轮传动总成	
C1016	1:6 转向C座件	
C1063	1:6 转向连杆	
C1308	1:6 吉姆尼 后桥成品	
C1309	1:6 吉姆尼 后钢板弹簧	
C1100	1:6 后轮轴	
C1310	1:6 吉姆尼 后桥胶件	
C1311	1:6 吉姆尼 避振器品成 (一对)	
C1312	1:6 吉姆尼 窗框	
C1313	1:6 吉姆尼 雨刷	
C1314	1:6 吉姆尼 座椅	
C1315	1:6 吉姆尼 前防撞	
C1316	1:6 吉姆尼 后防撞	
C1317	1:6 吉姆尼 车壳成品	
C1318	1:6 吉姆尼 高清镜	
C1319	1:6 吉姆尼 车轮成品(一对)	
C1320	1:6 吉姆尼 水箱	
C1321	1:6 吉姆尼 灯片	
C1322	1:6 吉姆尼 油箱盖	
C1323	1:6 吉姆尼 车尾门	
C1324	1:6 吉姆尼 车尾连杆	
C1325	1:6 吉姆尼 档杆	
C1326	1:6 吉姆尼 方向盘套件	
C1327	1:6 吉姆尼 车头盖	
C1328	1:6 吉姆尼 锁件	
C1329	1:6 吉姆尼 防滚架	
C1330	1:6 吉姆尼 防滚架	
C1331	1:6 吉姆尼 栏杆	
C1009	连杆波帽	
C1020	1:6 螺母包	
C1022	1:6 销针	
C1023	1:6 轴承包	
C1066	1:6 限滑器弹簧	
C1067	1:6 限滑片	
C1068	1:6 大齿42T 0.6	

DISTRIBUTOR

North America:
Horizon Hobby LLC
2904 Research Road
Champaign, IL 61822, USA
Tel.: 217-403-3584

Sweden:
Minicars Hobby Distribution AB
Annelundsgatan 17C
749 40 Enköping, Sweden
Tel.: +46-171-14 30 02

The United Kingdom:
CML Distribution Ltd
Saxon House, Saxon Business Park, Hanbury Road
Bromsgrove, Worcestershire
B60 4AD, England
Tel.: +44 (0)1527 575349

Australia:
Model Engines Pty Ltd
Unit 1/32 Bluett Drive
Smeaton Grange
NSW 2567 Australia
Tel.: +61(0)411128284

VERTEILER

Germany, Austria:
D-Power Modellbau
Sürther Str. 92-94
D-50996 Köln
Germany
Tel.: (0221) 346 641 57

DISTRIBUTEUR

France, Benelux:
Beez2B sprl
54 rue de Thy
B-1470 Baisy Thy
Belgique 3 Tél. : +32 2 376 71 82

Declaration of Conformity (DoC)

We,
Dongguan Solid Model Technology Co.,Ltd
3/F, Building B, 3rd Industry Zone,
Matigang, Dalingshan Town
Dongguan City of China 523810.

Phone:0769-86976655
Web:www.fmsmodel.com

declare under our responsibility that the product:
Type of Equipment: Driving System & 2.4GHz Control System
Brand Name: FMS
Compatiable for cars: 1:6 Jimny
Equipment Model: 10602



to which this declaration relates is in conformity with the essential requirements and other relevant requirements of the Directive 2014/53/EU, EMC Directive 2014/30/EU, EMC Directive 2014/53/EU, FCC Identifier 2AUBX-HT-TX02 , EU RoHS Directive 2011/65/EU and Council Directive 2014/30/EU. The product is in conformity with following standards and/or other normative documents:

ETSI EN 301 489-1 V2.2.3(2019-11)
ETSI EN 301 489-17 V3.2.4(2020-09)
EN 55032:2015+A11:2020
EN 55035:2017+A11:2020
EN61000-3-2:2014
EN61000-3-3:2013
EN : 62479:2010
ETSI EN 300 328 V2.2.2 (2019-07)



MADE IN CHINA