

**Flightline**  
RC.com

# F8F-1 BEARCAT

## USER MANUAL

1/9 SCALE

WINGSPAN:1200mm(47-1/4" )

LENGTH:930mm(36-1/2" )

WEIGHT:1530g(53.9 oz.)W/O BATTERY



**EPO**

**Scale Realism  
and  
Sport Performance**

EN 1~11

中 12~23

DE 24~41

Made in China



**FreeWing**  
www.sz-freeewing.com



### Brief History

The F8F "Bearcat" was Grumman's last piston engine fighter to conquer the skies. First taking flight in August 1944 and powered by a massive Double Wasp engine, the Bearcat's performance was superior to many jets of the same era. Over 1,200 Bearcats were produced, operating around the world and participating in conflicts from Korea to Vietnam. The F8F also served from 1946-1948 with the Blue Angels, the US Navy's premier flight demonstration squadron, and set the foundation for generations of inspiring excellence by Blue Angel pilots. In 2016, FlightLineRC commemorates the 70th Anniversary of the Blue Angels by presenting this electric flying model to inspire new generations to appreciate the historic F8F Bearcat.

### Overview

FlightLineRC presents an exciting 1/9 scale flying electric replica of the F8F-1 Bearcat. This EPO foam model assembles easily in minutes and features a scale profile with many plastic detail parts such as spring-loaded inner gear doors, highly detailed cowl and radial engine, and removable cannon barrels. The 1200mm wingspan is easy to transport and strategic carbon reinforcements provide lightweight strength. The Bearcat's magnetic hatch reveals a large battery compartment that can also accommodate a flight stabilization gyro (sold separately). Cooling airflow is channeled over the battery and ESC compartment. Large flaps help stabilize the aircraft for slow and controlled landings. Scale power is provided by a 3748-580KV brushless motor with 4-blade scale propeller, which provides impressive vertical climbing power and 120kph/75mph level speed on a 4s battery. An optional High Performance Power System Set provides 140kph/88mph level speed and increased vertical performance.

### Flight Features

FlightLineRC's F8F-1 Bearcat is a suitable aircraft for novice warbird pilots to advanced pilots. Its wide landing gear stance of 490mm provides stable ground handling especially on grass when compared to other aircraft with more narrow gear stances or smaller wheels. The power to weight ratio also allows for most any acrobatic maneuver you can imagine, yet the Bearcat's large wing and flying surfaces are most conducive to stable, scale flight, for an overall relaxing flying experience. Landing under power with full flaps can yield a very short landing length, which is ideal for pilots flying in confined areas.

### Color scheme introduction

The FlightLineRC F8F-1 Bearcat arrives completely painted in dark blue, with green gear wells. Included in the box are two optional decal sets:

1. Blue Angels Demonstration Team, 1946 (including our special 70 anniversary decal)
2. US Naval Reserve, Olathe, Kansas, 1948

Other decal sets are also sold separately to further customize your model. Please contact your FlightLineRC ([www.motionrc.com](http://www.motionrc.com)) dealer for more information.

**⚠ NOTE:** This is not a toy. Not for children under 14 years. Young people under the age of 14 should only be permitted to operate this model under the instruction and supervision of an adult. Please keep these instructions for further reference after completing model assembly.

### Note:

1. This is not a toy! Operators should have some basic experience. Beginners should operate only under the guidance of an professional instructor.
2. Before beginning assembly, please read through the instructions carefully and follow the instructions through the build.
3. Freewing and it's vendors will not be held responsible for any losses due to improper assembly and operation.
4. Model airplane operators must be at least 14 years of age.
5. This airplane is made with EPO material, covered with surface spray paint. Don't use chemicals to clean as it may cause damage.
6. You should avoid flying in areas such as public places, areas with high voltage power lines, nearby highways or airports or any other areas where laws and regulations clearly prohibit.
7. Do not fly in bad weather conditions, including thunderstorms, snow, etc...
8. Lipo batteries should be properly stored in a fire safe container and be kept at a minimum 2M distance away from and flammable or explosive materials
9. Damaged or scrap batteries must be properly discharged before disposal or recycling to avoid spontaneous combustion and fire.
10. At the Flying Field, properly dispose of any waste you have created, don't leave or burn your waste.
11. Ensure that your throttle is in the low position and that your radio is turned on before connecting your Lipo battery.
12. Do not try to catch the airplane when flying low or landing. Wait for the airplane and its propeller to come to a complete stop.

## Catalog

- |   |   |
|---|---|
| <b>2 Product basic information</b>          | <b>7 Control board use introduction</b> |
| <b>2 Package list</b>                       | <b>7 Parameter of motor</b>             |
| <b>3 PNP install instructions</b>           | <b>8 Install power system</b>           |
| <b>4 Servo instructions</b>                 | <b>9 Center of Gravity</b>              |
| <b>5 Pushrod instructions</b>               | <b>10 Control direction test</b>        |
| <b>6 Landing gear assemble instructions</b> | <b>11 Dual rates</b>                    |
| <b>7 Battery Installation</b>               | <b>11 Installing the Plastic Hinges</b> |

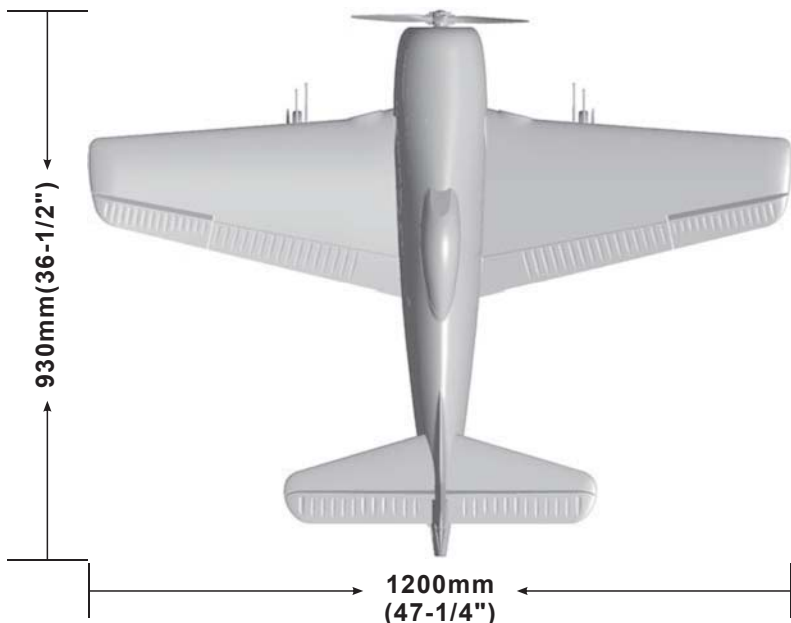

Wing loading: 76g/dm<sup>2</sup>  
 Motor: 3748-580KV brushless motor  
 Propeller: 4-blade 12x7  
 ESC: 60A brushless ESC  
 Servo: 9g MGx2, 9g plasticx4  
 Weight: 1530g (w/o battery)

Aileron: Yes  
 Elevator: Yes  
 Rudder: Yes  
 Flap: Yes  
 Landing gear: Retract landing gear  
 Main landing gear cabin door  
 Material: EPO

**High speed DIY spare-parts**

(The following are DIY spare parts, contact your distributor to purchase these items separately)

*3648-880KV brushless motor*  
*2-blade 12x8 propeller.*

**⚠ Note:** The parameters in here are derived from test result using our accessories. If use other accessories, the test result will be different. Any problem since of using other accessories, we are not able to provide technical support.

**Package list**



Different equipment include different spareparts. Please refer to the following contents to check your sparepart list.

No.	Spareparts name	PNP	ARF Plus	ARF
1	Fuselage	Pre-installed all electronic parts	Pre-installed servo	No electronic equipment
2	Main wing	Pre-installed all electronic parts	Pre-installed servo	No electronic equipment
3	Horizontal tail	Pre-installed all electronic parts	Pre-installed servo	No electronic equipment
4	Decals / Manual	✓	✓	✓
5	Control board	✓	✓	✓

No.	Spareparts name	PNP	ARF Plus	ARF
6	Propeller and parts	✓	✓	✓
7	Spinner and parts	✓	✓	✓
8	Carbon tube	✓	✓	✓
9	Glue and Screws	✓	✓	✓
10	Pushrod/Plastic parts	✓	✓	✓

**Install main wing**

- A-Carbon tube (Ø8x255mm)
- B-Servos wire
- C-Servo Wire Slots
- d

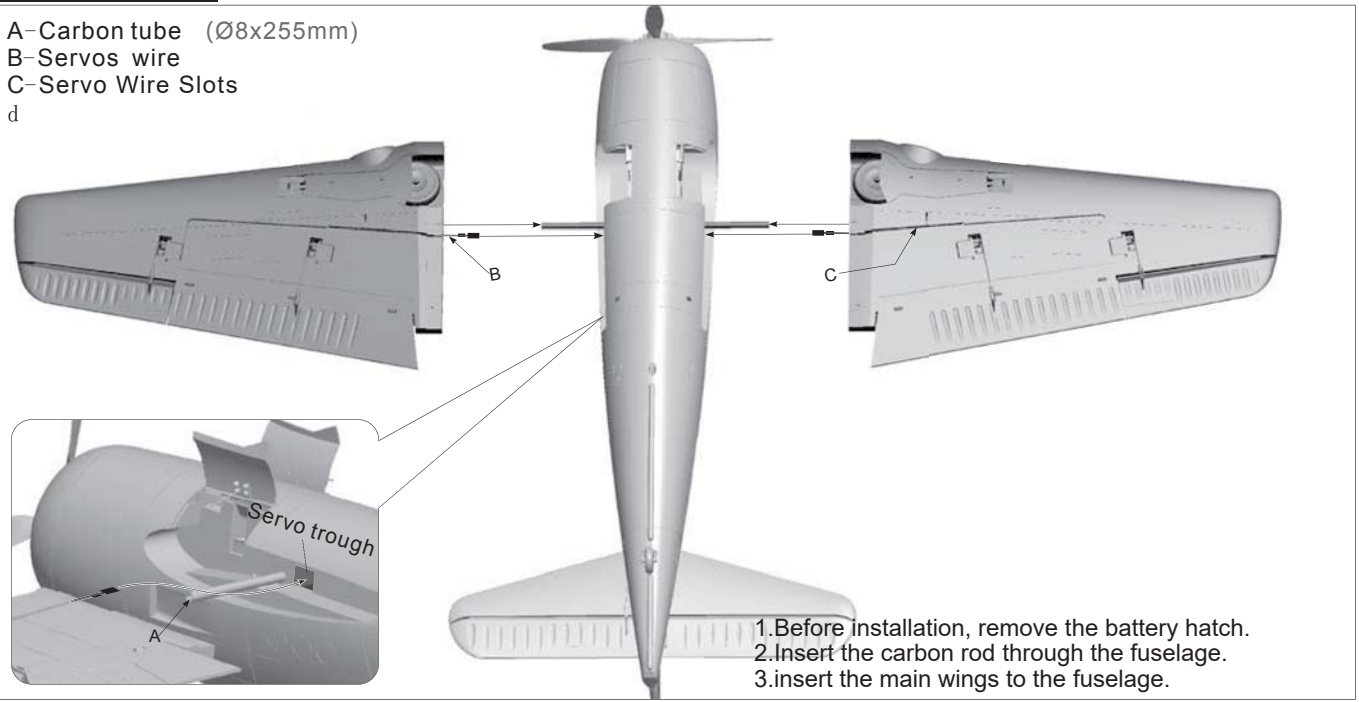

1. Before installation, remove the battery hatch.
2. Insert the carbon rod through the fuselage.
3. Insert the main wings to the fuselage.

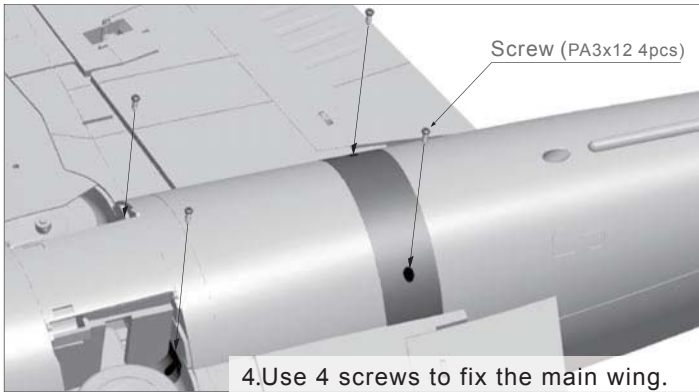

4. Use 4 screws to fix the main wing.



5. Insert the guns to the main wing carbon tube holes.

**Install elevator**

1. Install the left/right elevator on the tail fuselage, as shown in the picture
2. Use 4 screws to affix the elevator to the fuselage.

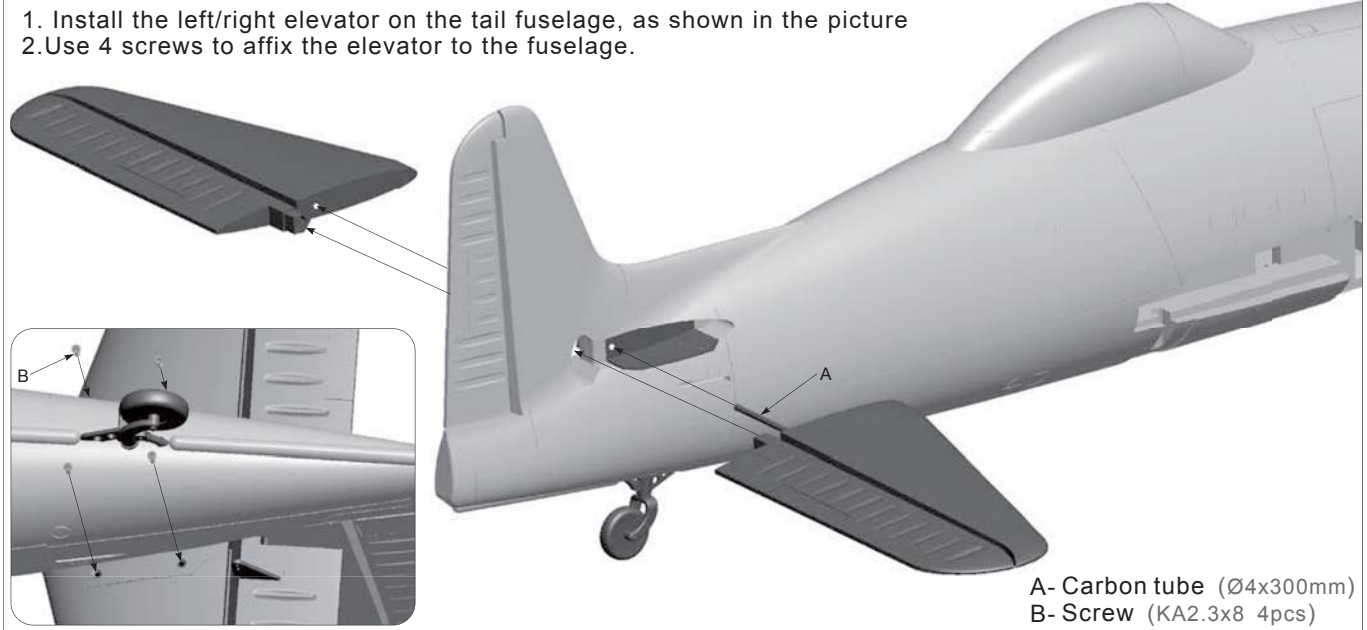

- A- Carbon tube (Ø4x300mm)
- B- Screw (KA2.3x8 4pcs)



**Install elevator/rudder pushrod**

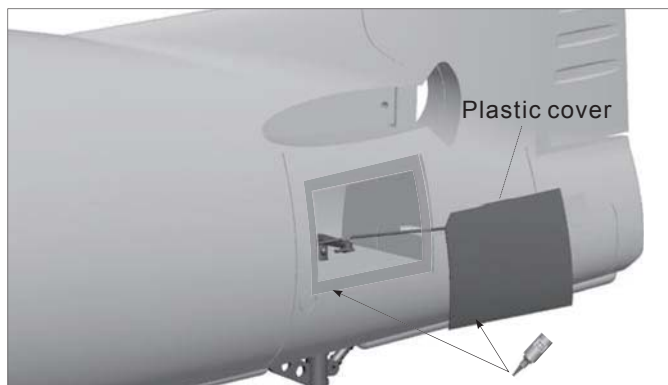
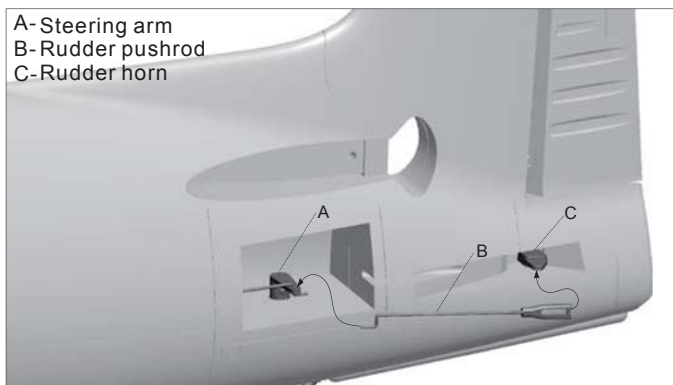
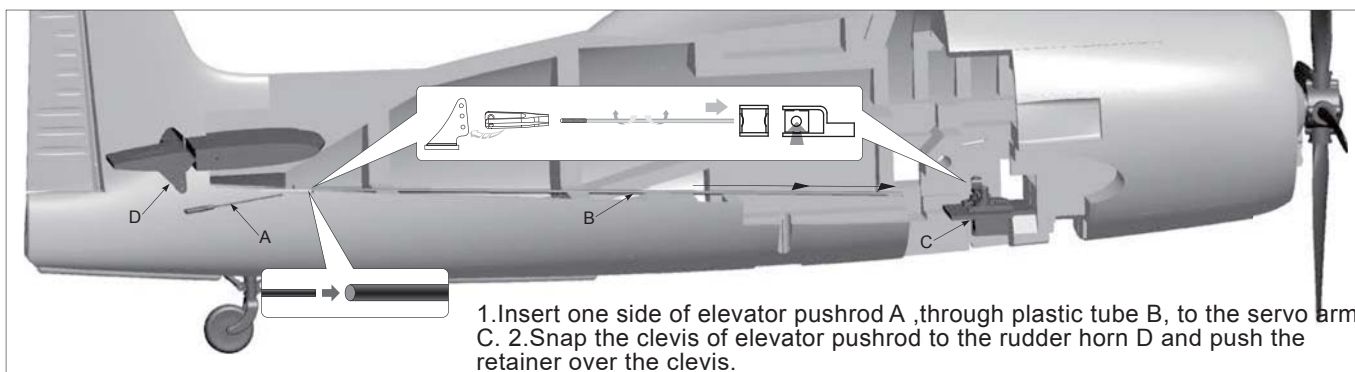

1. Use rudder pushrod to connect the steering arm to the rudder horn.
2. Use glue to attach the plastic cover (as shown in the photo above.)

**⚠ Note:** when installing the rudder pushrod, make sure that the tail wheel is centered, then adjust the clevis so that the pushrod attaches to the rudder so it is centered as well.

**Servo introduction**

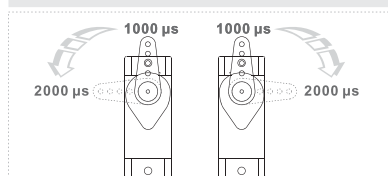

A positive or reversed servo is defined as:  
 when a signal from 1000us to 2000us is applied, if the servo rotates in a clockwise direction, it's positive.  
 If the servo rotates in counter clockwise direction, it's reversed.

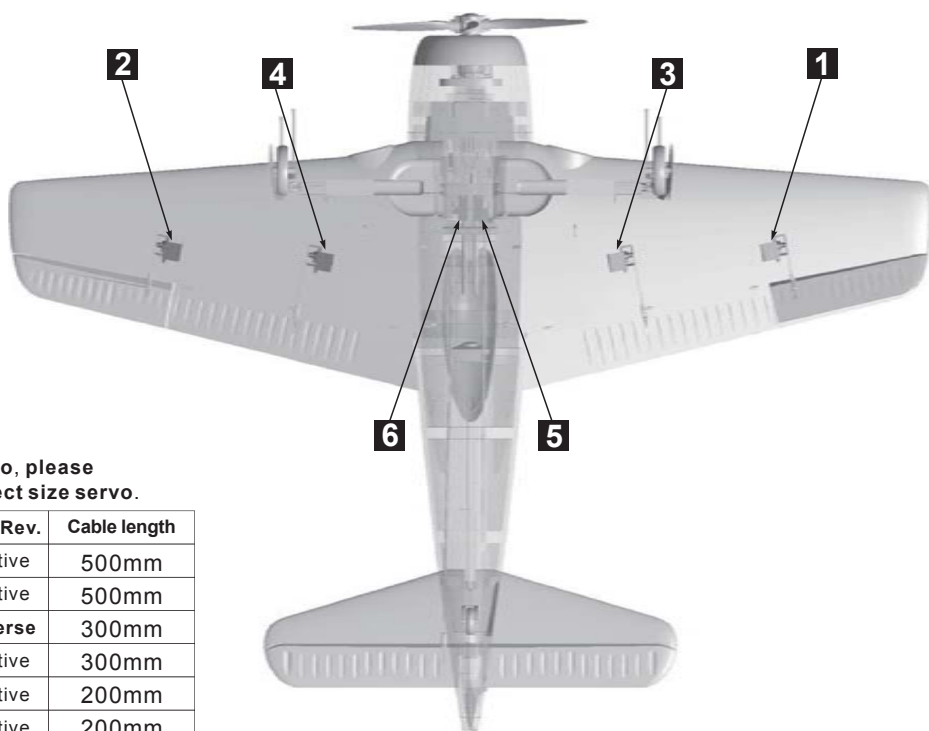

If you need to purchase other brand servo, please refer to the following list to choose correct size servo.

Position	Model	No.	Pos./Rev.	Cable length
Aileron(Left)	9g Digit-Plastic	1	Positive	500mm
Aileron(Right)	9g Digit-Plastic	2	Positive	500mm
Flap(Left )	9g Digit-Plastic	3	<b>Reverse</b>	300mm
Flap(Right)	9g Digit-Plastic	4	Positive	300mm
Rudder	9g Digital MG	5	Positive	200mm
Elevator	9g Digital MG	6	Positive	200mm

## Install main wing servos

1. Use a servo tester or radio to center the servo.
2. Use glue to install the servo and aileron horn on the main wing.
3. Route the servo cables through the wiring slots. After installing all the servos, apply the covering decal.
4. Attach the pushrod to the servo, adjust the length to center the control surface, then attach the clevis to the control horn.
5. Repeat these four steps for the other wing.

A - 9g servo  
 B - Main wing pushrod  
 C - Aileron horn  
 D - Main wing servo trough

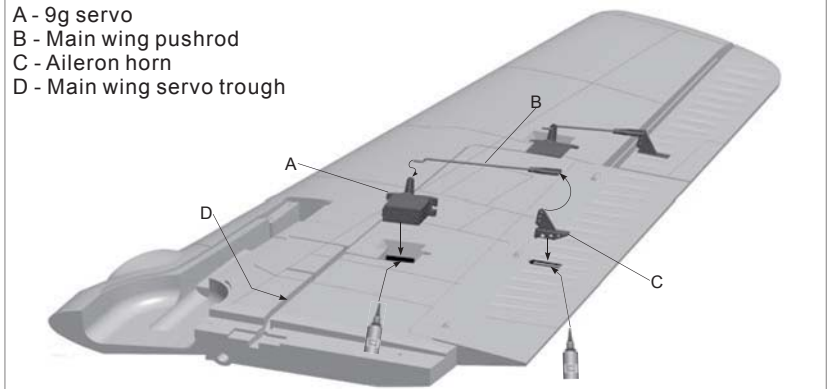

## Install the servo of Elevator/rudder

1. Use a servo tester or radio to center the servo.
2. Use screw A to affix the 9g servo to the wooden base.
3. Route the servo cable under the wooden base to the battery compartment.

**⚠ Note:** If you choose to use a non factory servo, the servo's dimensions may be different. If that is the case, you will need to modify or remove the wooden base and attach the servo to a better position.

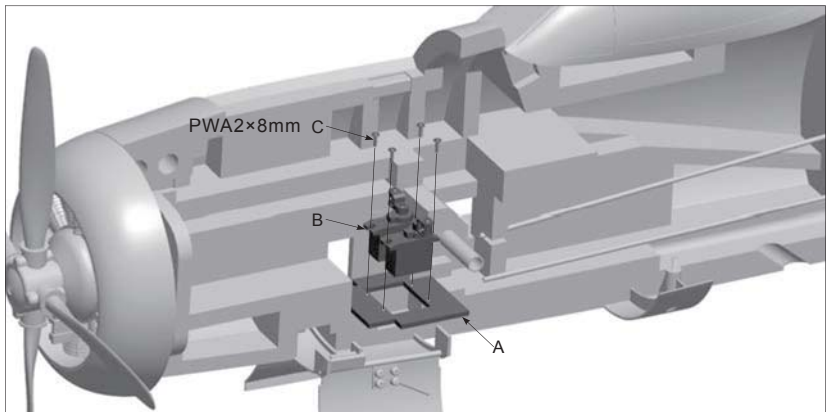

## Pushrod instructions

### Steering pushrod size

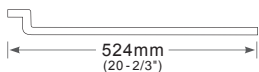

Pushrod diameter Ø1.2mm

### Steering pushrod mounting hole



### Rudder pushrod size

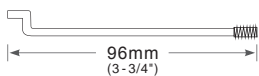

Pushrod diameter Ø1.2mm

### Rudder pushrod mounting hole



### Elevator pushrod size

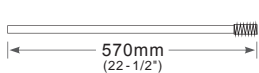

Pushrod diameter Ø1.2mm

### Elevator pushrod mounting hole



### Aileron pushrod size

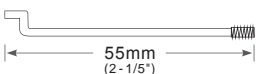

Pushrod diameter Ø1.2mm

### Aileron pushrod mounting hole



### Flap pushrod size

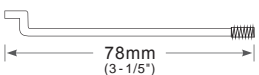

Pushrod diameter Ø1.2mm

### Flap pushrod mounting hole



## Nose Landing Gear Assemble

Please assemble, disassemble the nose landing gear according to the following photo.

- A - Nose gear main supporting rod
- B - Nose wheel (Ø65×16mm)
- C - Wheel-chocks (Ø5.5×Ø4.2mm)
- D - Jimi screw (M3×3mm)
- E - Nose gear cabin door A
- F - Screw- (PB2.3×4mm)
- G - Retract servo.
- H - Screw (M3×3mm)
- I - Screw (KA2.6×12mm 4pcs)
- J - Nose landing gear
- K - Landing gear mount
- L - Cabin door mount
- M - Nose gear cabin door B
- N - Cabin door pushrod (65×10mm 2pcs)

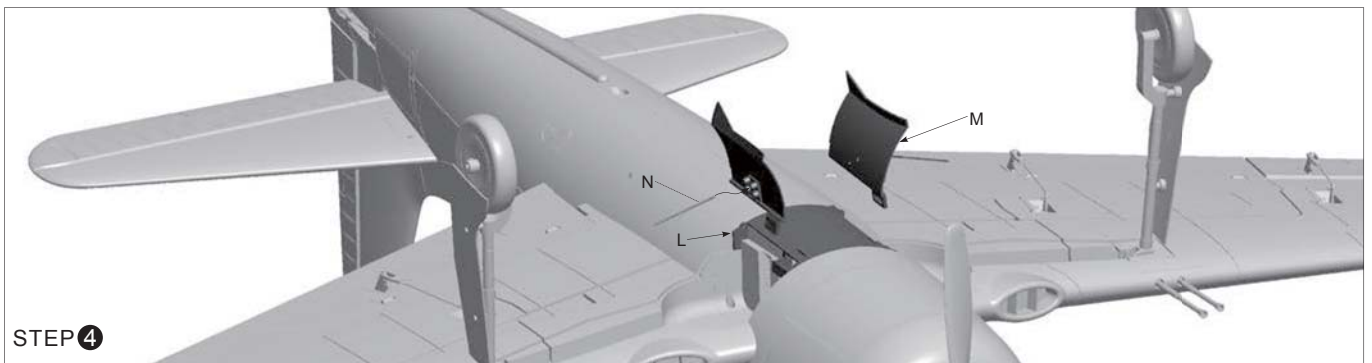
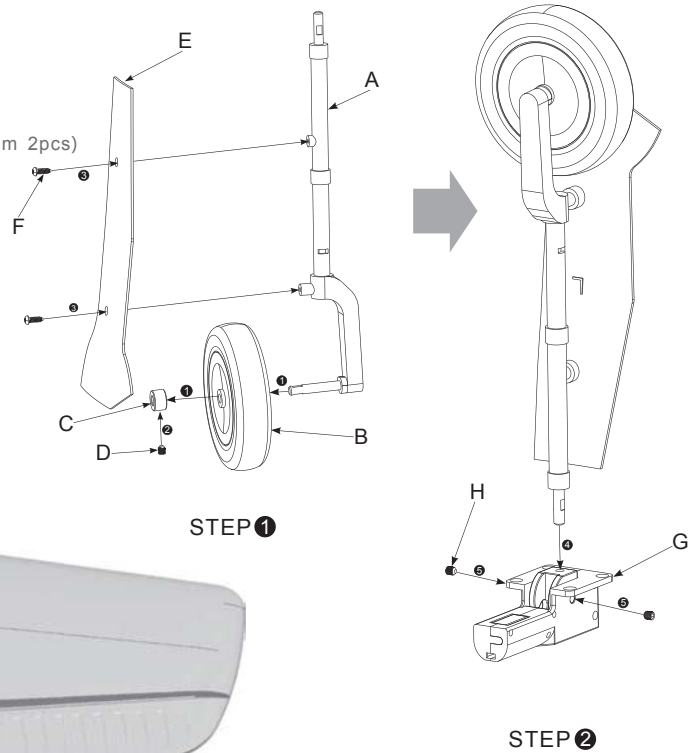
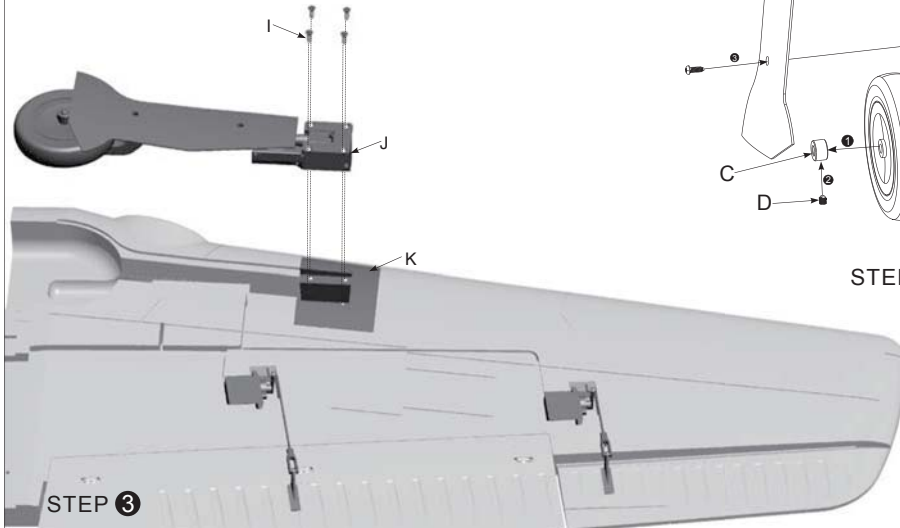

## Install the tail gear set

1. Refer to the right photo, install the tail landing gear set.
2. Insert the tail gear set C to the fixed plastic part B, and then insert the assembly to the tail steering arm A.
3. Use screw D to fix the tail steering arm.

- A - Rear wheel (Ø35×10mm)
- B - Rear gear supporting rod
- C - Rear wheel shaft
- D - E-buckle (Ø5×Ø2mm)

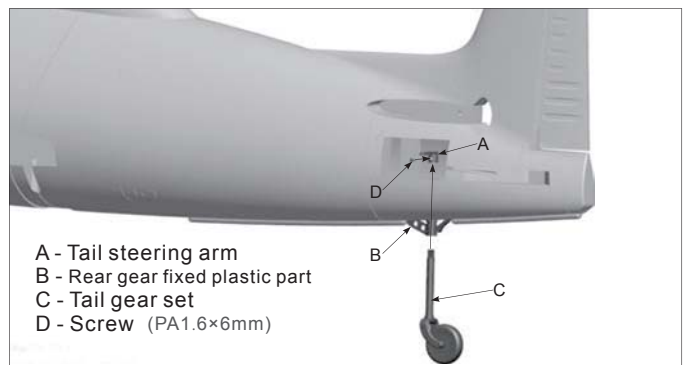
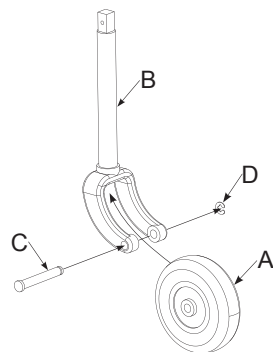

## Install on battery

EN

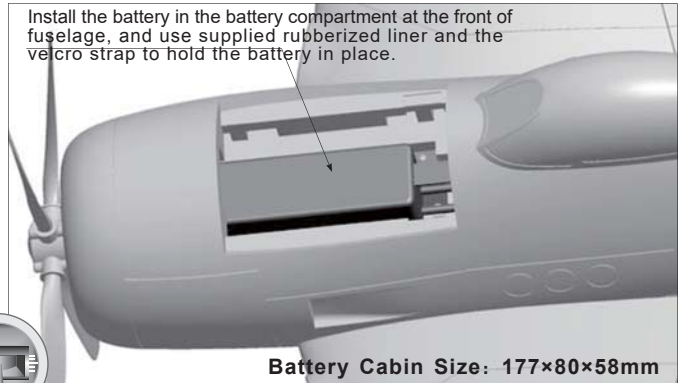
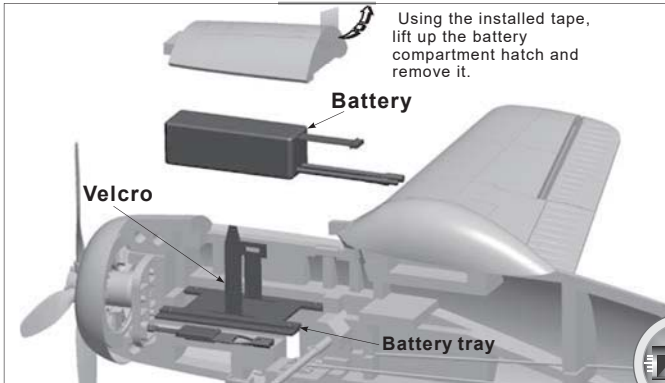

Before connecting the battery and receiver, please switch on the transmitter and make sure the throttle stick is in the lowest position.

The battery capacity and discharge rate we advise is in the following:  
**4S 14.8V 2600mAh ~ 4S 14.8V 4000mAh**  
**Discharge rate of C ≥ 35C**

## Control board use introduction

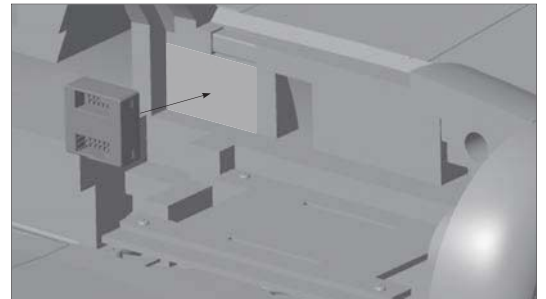
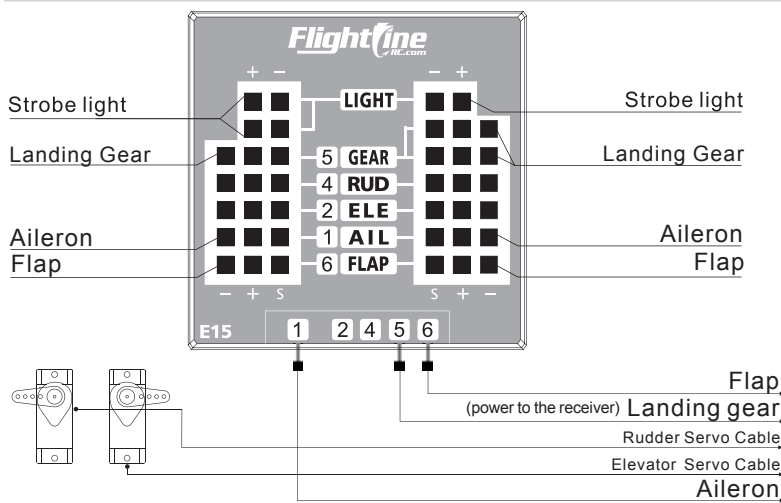

Refer to the markings on control board, connect all cables to the control board. After connecting wires, use glue to affix the control board, to the side of the fuselage.

Note: This model comes with a slightly different control board. It has outputs for Ailerons, Flaps and Landing Gear only. Connect all other control inputs directly to the receiver.

## Parameter of Motor

### Motor shaft

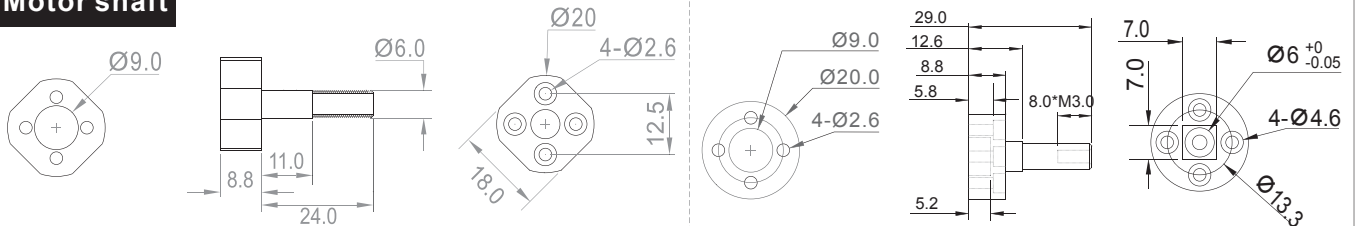

### X-fixed base

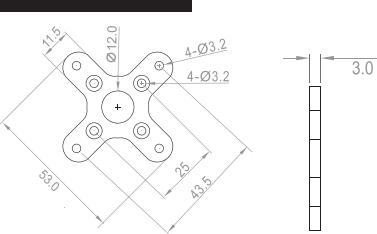

### Motor size

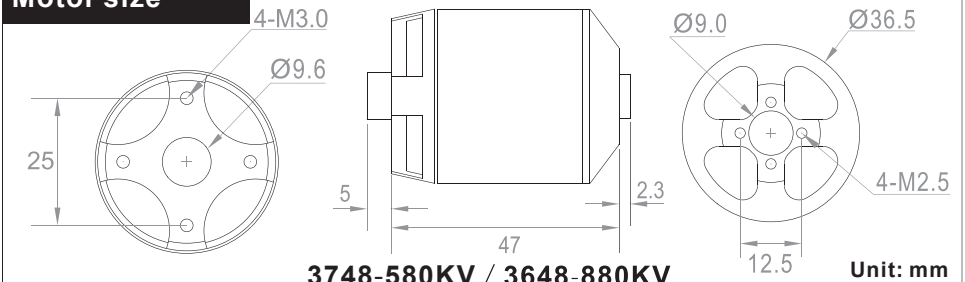

Item No.	KV Value	Volute (V)	Current (A)	Pull (g)	Motor Resistance	Weight (g)	No Load Current	Propeller	ESC
MO137481	580RPM/V	14.8	41	2500	0.02 Ω	170	2.3A/10V	4-Blade12×7	≥60A
MO136484	880RPM/V	14.8	53	2600	0.02 Ω	165	2.3A/10V	2-Blade12×8	≥60A



## Install power system

EN

- A- Screw (KM3×5mm 4pcs)
- B- Motor X-fixed base
- C- 3748-580KV out-runner motor
- D- Propeller folder
- E- Screw (HM2.5×10mm 4pcs)

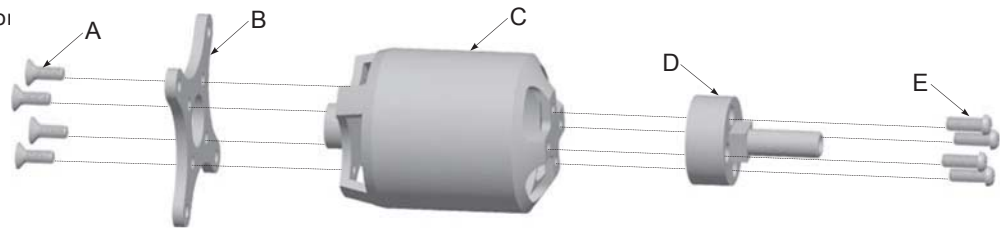

- A- Motor fixed mount
- B- Screw (PA3×12mm 4pcs)
- C- Radial Engine Cover
- D- Screw (PWA2×8mm 4pcs)

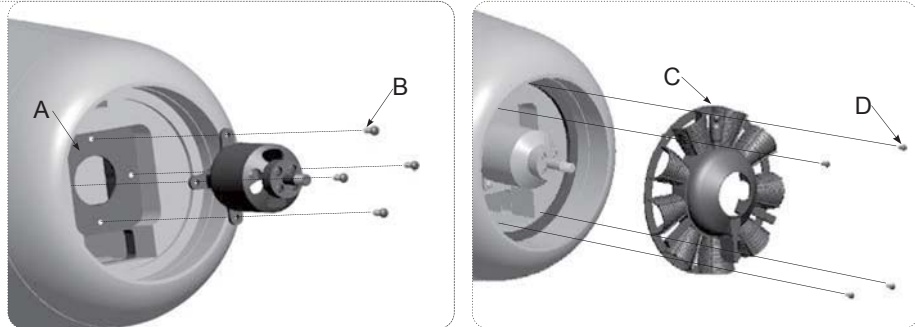

- A- Spinner
- B- Propeller (12×7 4pcs)
- C- Propeller fixed plate
- D- Screw (KA2.3×20mm 8pcs)
- E- 3748-580KV brushless motor
- F- Screw (PM3×10mm 1pcs)

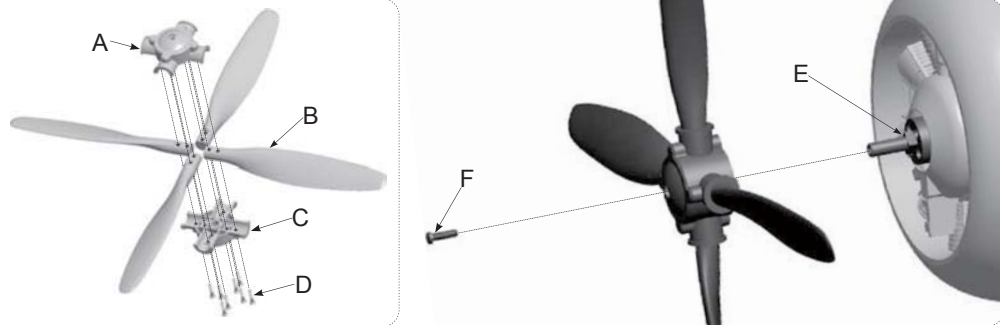

## Install 2-blade propeller high power system

- A- Screw (KM3×5mm 4pcs)
- B- Motor X-fixed base
- C- 3648-880KV out-runner motor
- D- Propeller folder
- E- Screw (HM2.5×10mm 4pcs)

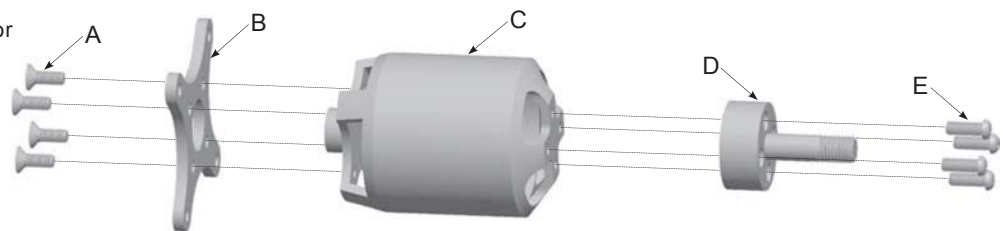

- A - 3648-880KV brushless motor
- B - 2-blade propeller (12×8)
- C - Washer (Φ14x1.5xΦ6.2)
- D - Motor Shaft

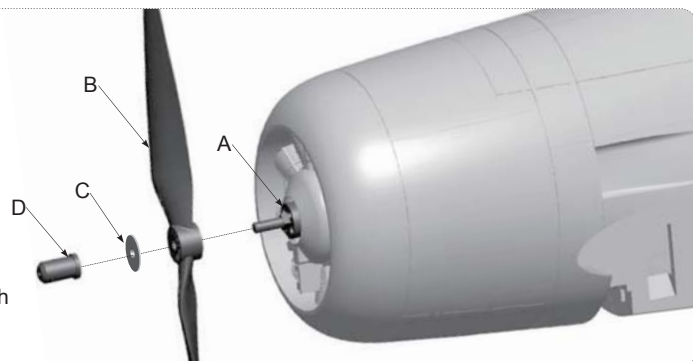

We offer a 2-blade high power system for this airplane which can improve the flight performance. Contact our distributor for more information or to purchase this upgrade.

## Install the power system

EN

### Install the ESC

- A-Screw (PWA3×8mm 4pcs)
- B-Battery tray
- C-ESC
- D-Tray holder

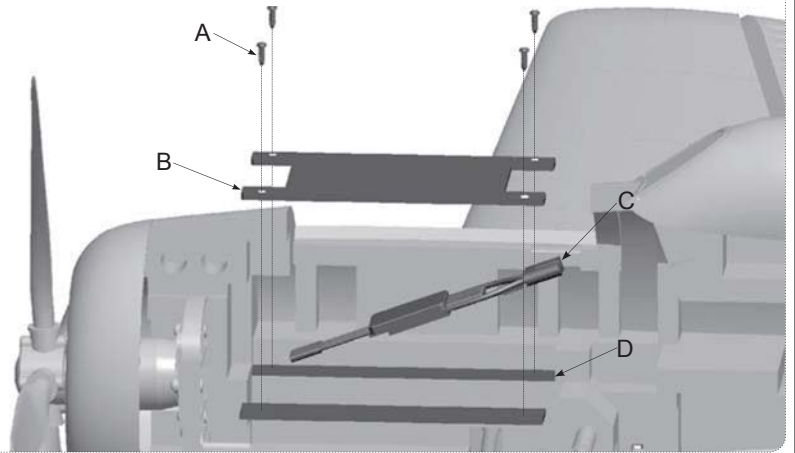

Put the ESC under the battery tray, there are specially designed vents to cool the electrical components

## Center of Gravity

Correct center of gravity is directly related to the success of the flight, please refer to the following CG diagram to adjust your plane's center of gravity.

- You can move the center of gravity by moving the battery, a suitable material such as stick on lead weight pad can be used.

85mm  
(3-3/8")

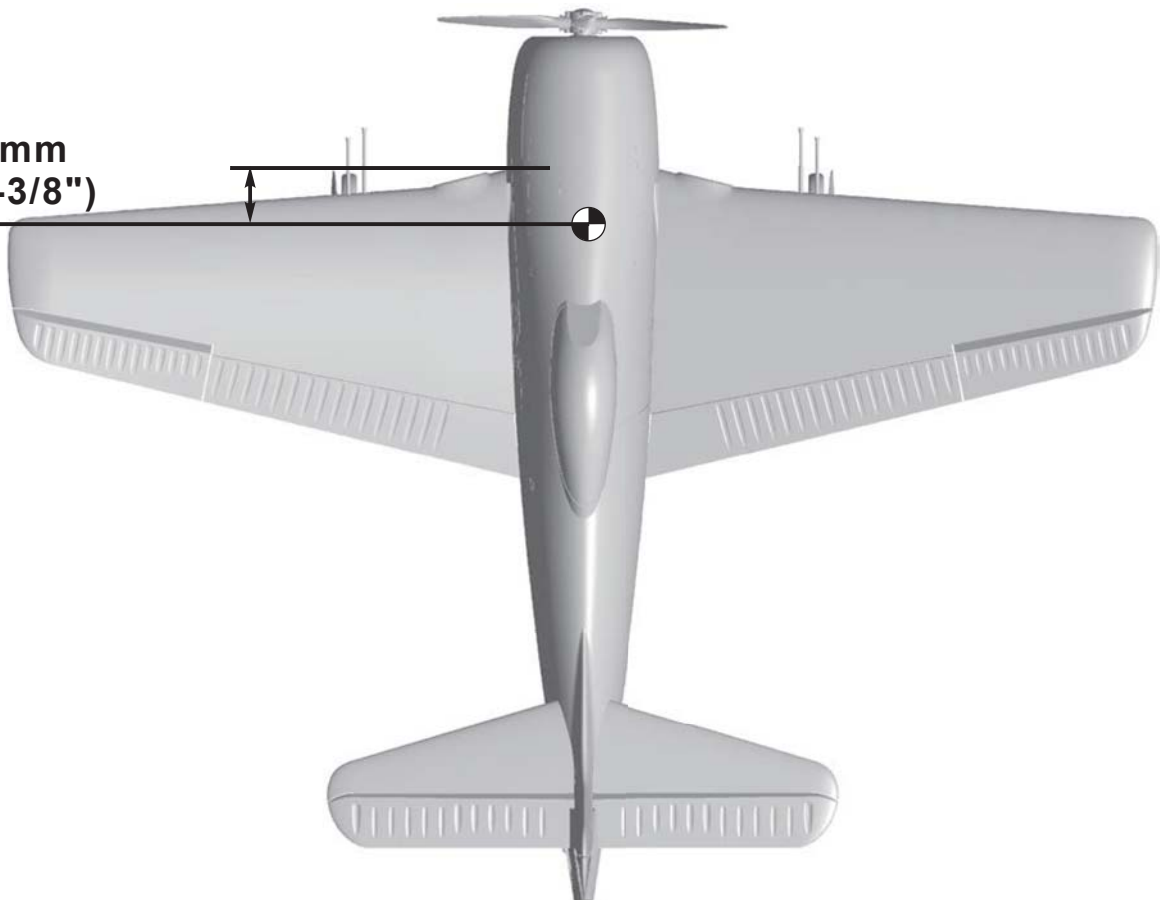

After assembly, before the first flight, with the propeller removed, power on the radio and connect a fully charged battery to the ESC. Then use the radio to check the control surface movement

## Aileron

Stick Left



Stick Right



## Elevator

Up Elevator

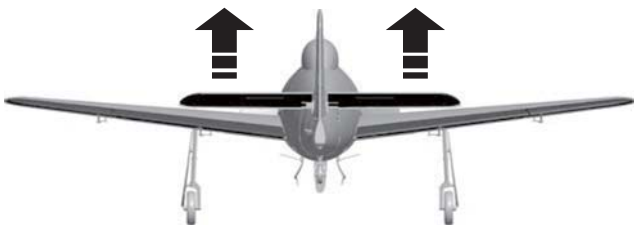

Down Elevator

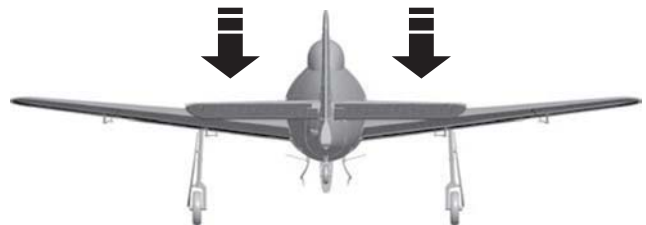

## Rudder

Stick Left

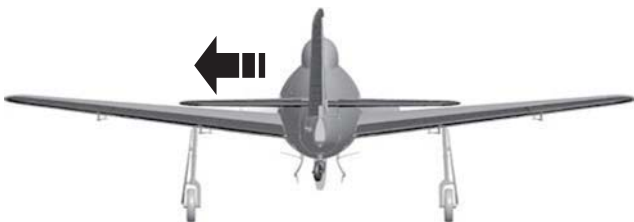

Stick Right

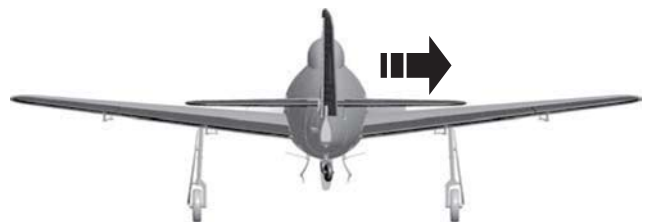

## Optional Flaps

Flaps down



According to our testing experience, according to the following parameters to set the aileron/elevator rate, it will be useful for flight. In low rate, its good for flight control and its suitable for the initial flight or less skilled players. According to your own circumstance, choose one rate in flight.

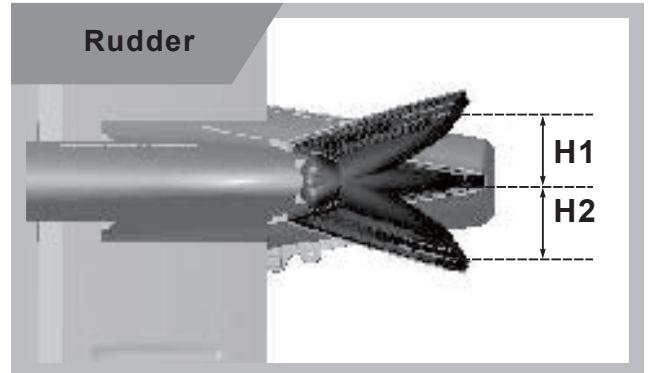
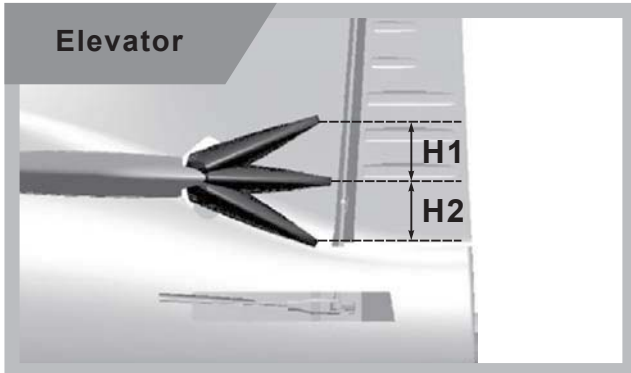
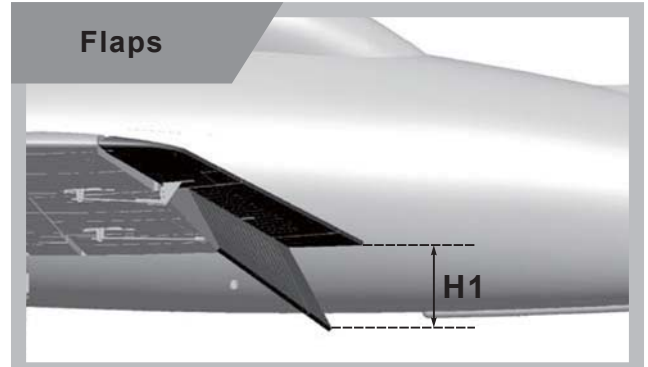
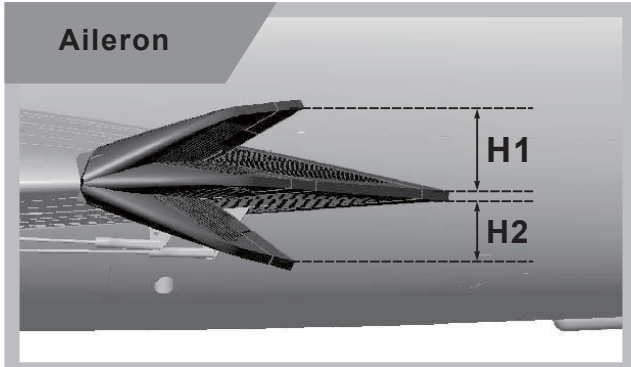

	Aileron	Elevator	Rudder	Flaps
<b>Low Rate</b>	H1/H2 20mm/20mm D/R Rate : 80%	H1/H2 20mm/20mm D/R Rate : 90%	H1/H2 16mm/16mm D/R Rate : 80%	H1 20mm
<b>High Rate</b>	H1/H2 25mm/25mm D/R Rate : 100%	H1/H2 23mm/23mm D/R Rate : 100%	H1/H2 20mm/20mm D/R Rate : 100%	H1 30mm

## Install the plastic hinges

The surface controls use a no-hinge connection design. It has proven to be a reliable design, however, we don't exclude the possibility, while in use, that errors causing the surfaces to tear or break may occur. So, we have included one set of plastic pin hinges, to provide convenience if repairs are needed. Please refer to the instructions below:

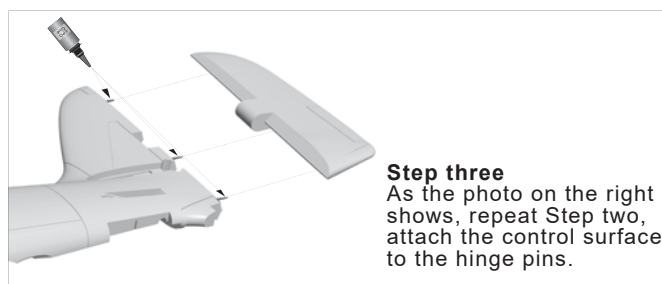
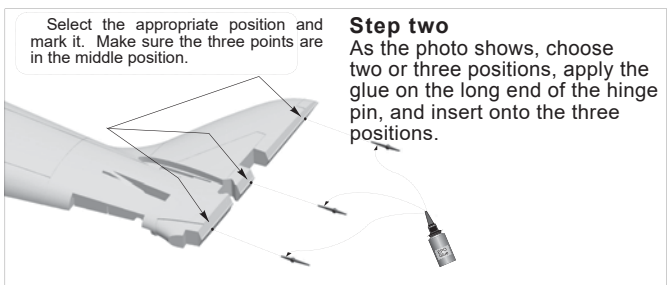





**„Wünsch Dir viel Spass mit dem  
gekauften Produkt.“**



**Modellneuheiten sowie unseren Europa-Shop  
findest Du unter:**

**[www.freewing.eu](http://www.freewing.eu)**



**[www.facebook.com/freewing.eu](http://www.facebook.com/freewing.eu)**

**Shenzhen Freewing Model Co.,Ltd  
HK Freewing Model International Limited**

East2/F,No.5 Blog.DongLongXing Industry Park,Huaning Road,Dalang  
Longhua Town,Baoan,Shenzhen,China