

F-16 FIGHTING FALCON

User Manual

WINGSPAN: 955MM(37.6 ")

LENGTH: 1457MM(57.4 ")

EMPTY WEIGHT: 3156G (W/O BATTERY)



EN 1~11

中 12~22

- 1 Introduction
- 2 Product basic information
- 2 Package list
- 3 PNP Assembly instructions
- 3 Install Fuselage
- 3 Install Speed brake
- 4 Install the Horizontal tail
- 4 Install the Vertical tail
- 5 Install the Main Wing
- 6 Install nose cone and decorated parts
- 7 Battery instructions
- 7 Important additional notes
- 8 Center of gravity
- 9 Control direction test
- 10 Dual rates
- 11 Servo direction
- 11 Motor specification

- 12 前言
- 13 产品规格参数
- 13 包装列表
- 14 PNP组装步骤介绍
- 14 机身组装
- 14 减速板组装
- 15 平尾组装
- 15 垂尾组装
- 16 主翼组装
- 17 仿真小配件、机头罩安装
- 18 电池介绍
- 18 舵面控制钢丝尺寸及安装孔位
- 19 重心示意图
- 20 模型舵面测试
- 21 舵量范围
- 22 舵机介绍
- 22 电机介绍

Thank you for purchasing our Freewing 90mm EDF super scale electric model jet---F16C "Fighting Falcon" V2. Before assembling this jet, please carefully read the instruction manual and assembly video, and assemble, set up, and debug it in the correct way. During this process, if you encounter special problems that cannot be solved on your own, please contact the dealer immediately or directly contact us for assistance.

The size of the new F-16C Falcon V2 model jet has not changed and is still produced in a 1/10 ratio. The wingspan is 955mm, the length is 1457mm, and EPO is the main material. However, 95% of its components are manufactured using new molds. Compared to the old version, it feels like a complete transformation, achieving a leapfrog upgrade. The V2 version of F-16C has the following improvements and optimizations compared to the previous generation:

- | | |
|--|--|
| -New camouflage color scheme | -The mounting type (including the auxiliary fuel tank) adopts a slide rail quick release structure |
| -Add plastic protective covers for edge wings | -Quick disassembly of front and rear fuselage |
| -Add plastic protective covers along the edge of the battery compartment | -Add electric scale speed brakes |
| -Add wing corner protective covers | -Add hidden auxiliary air inlet |
| -Add fuselage markings and rivet details | -Enhance the structural strength of landing gear fixed mounts |
| -Landing gear shape adjustment | -Change the cabin door to the plastic cabin door made of molds |
| -Painting and coloring of landing gear | -Scale LED light group |
| -Application of plastic parts in other detailed positions | -Improved V2 version cockpit latch |
| -Optional scale instrument panel and scale seat | -Increase battery compartment space to accommodate 8S batteries. |
| -Adopting QUICK portable install structure of main wing | -Aerodynamic performance optimization |

It can be seen that the new V2 version of the F-16C model aircraft not only has a more exquisite appearance, but also will bring us a more convenient operating experience and a better flying experience. In terms of power, there will be two versions to choose from:

The 6S standard version equipped with E72216 power system (3668-1960KV in-runner motor, 12-blade duct fan) and 120A brushless ESC. The maximum level flight speed is 185KPH.

8S upgraded version, equipped with E72215 power system (4075-1350KV in-runner motor, 12-blade duct fan with metal frame), 120A brushless ESC. The maximum level flight speed is 210KPH, with strong power and extremely strong long-term vertical climbing ability!

The F-16C fighting falcon V2 model jet has further optimized the aerodynamic design, providing excellent stability during flight. Compared to the older version, the flight quality has been greatly improved. The new landing gear has not only been improved in terms of appearance, but also made targeted improvements by statistically analyzing past problems, making it more sturdy and durable. The newly added electric speed brake can effectively reduce flight speed and better assist landing.

Thank you again. We hope that this new remade V2 version of F-16C "Fighting Falcon" can bring you a better experience. We wish you a successful flight!

Note:

- 1.This is not a toy! Operator should have a certain experience, beginners should operate under the guidance of professional players.
- 2.Before install, please read through the instructions carefully and operate strictly under instructions.
- 3.Cause of wrong operation,Freewing and its vendors will not be held responsible for any losses.
- 4.Model planes' players must be on the age of 14 years old.
- 5.This plane used the EPO material with surface spray paint, don't use chemical to clean, otherwise it will damage.
- 6.You should be careful to avoid flying in areas such as public places,high-voltage-intensive areas,near the highway, near the airport or any other place where laws and regulation clearly prohibit.
- 7.You cannot fly in bad weather conditions such as thunderstorms,snows....
- 8.Model plane's battery, don't allowed to put in everywhere. Storage must ensure that there is no inflammable and explosive materials in the round of 2M range.
- 9.Damaged or scrap battery should be properly recycled, it can't discard to avoid spontaneous combustion and fire.
- 10.In flying field, the waste after flying should be properly handled,it can't be abandoned or burned.
- 11.In any case, you must ensure that the throttle is in the low position and transmitter switch on, then it can connect the lipo-battery in aircraft.
- 12.Do not try to take planes by hand when flying or slow landing process. You must wait for landing stop, then carry it.

⚠ NOTE: This is not a toy. Not for children under 14 years. Young people under the age of 14 should only be permitted to operate this model under the instruction and supervision of an adult. Please keep these instructions for further reference after completing model assembly.



6S Standard Version

Wingload: 205g/dm²
 Wing Area: 18.8dm²
 Servo: 9gHybrid digital servo(6pcs)
 17gMG digital servo(3pcs)
 23gMG digital servo(2pcs)
 Motor: 3668-1960KV I/R Motor
 Ducted fan: 90mm 12-blade fan
 ESC: 120A Brushless (Thrust Reverse Function)
 Weight: 3156g(w/o Battery,missile / missile:184g)
 Li-Po Battery: 6S 5000-6000mAh
 Landing gear: electric retracts and aluminum shock absorber struts, scale decorated part

8S Upgrade Version

Motor: 4075-1350KV I/R Motor
 Ducted fan: 90mm 12-blade fan
 Weight: 3300g(w/o Battery,missile / missile:184g)

Other features

Cabin doors: front and rear complete
 cabin doors, servo control
 Navigation lights: LED navigation lights
 Other:Speed brake

Simulated cockpit 3D printing set (need to purchase separately)

Note: The parameters in here are derived from test result using our accessories. If use other accessories, the test result will be different. Any problem since of using other accessories, we are not able to provide technical support.

Package List

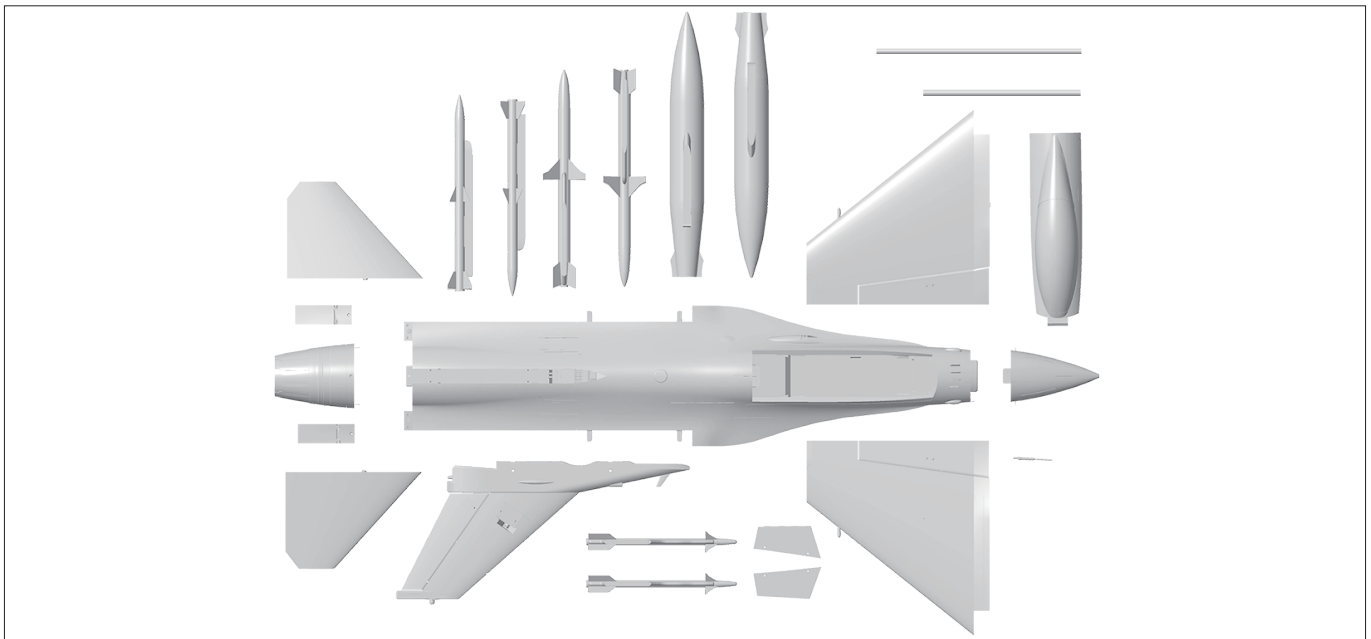

Different equipment include different spareparts. Please refer to the following contents to check your sparepart list.

NO.	Name	PNP	ARF Plus	NO.	Name	PNP	ARF Plus
1	Fuselage	Pre-installed all electronic parts	Pre-installed servo	6	Cockpit,Nose cone	✓	✓
2	Main wing	Pre-installed all electronic parts	Pre-installed servo	7	Fins,carbon tube	✓	✓
3	Horizontal tail	Pre-installed all electronic parts	Pre-installed servo	8	Part bag	✓	✓
4	Vertical tail	Pre-installed all electronic parts	Pre-installed servo	9	Missile	✓	✓
5	Speed brake	✓	✓	10	Manual	✓	✓

Install Fuselage

As the photo show:

1. Use glue to fix the 【Conical plastic part】 on two carbon tubes respectively;
2. Align the carbon tube with the fuselage, and push the rear fuselage into its installation position;
3. After installed the rear fuselage onto the front fuselage, tighten it with two screws.

Screw (KM 3*7mm 2PCS)

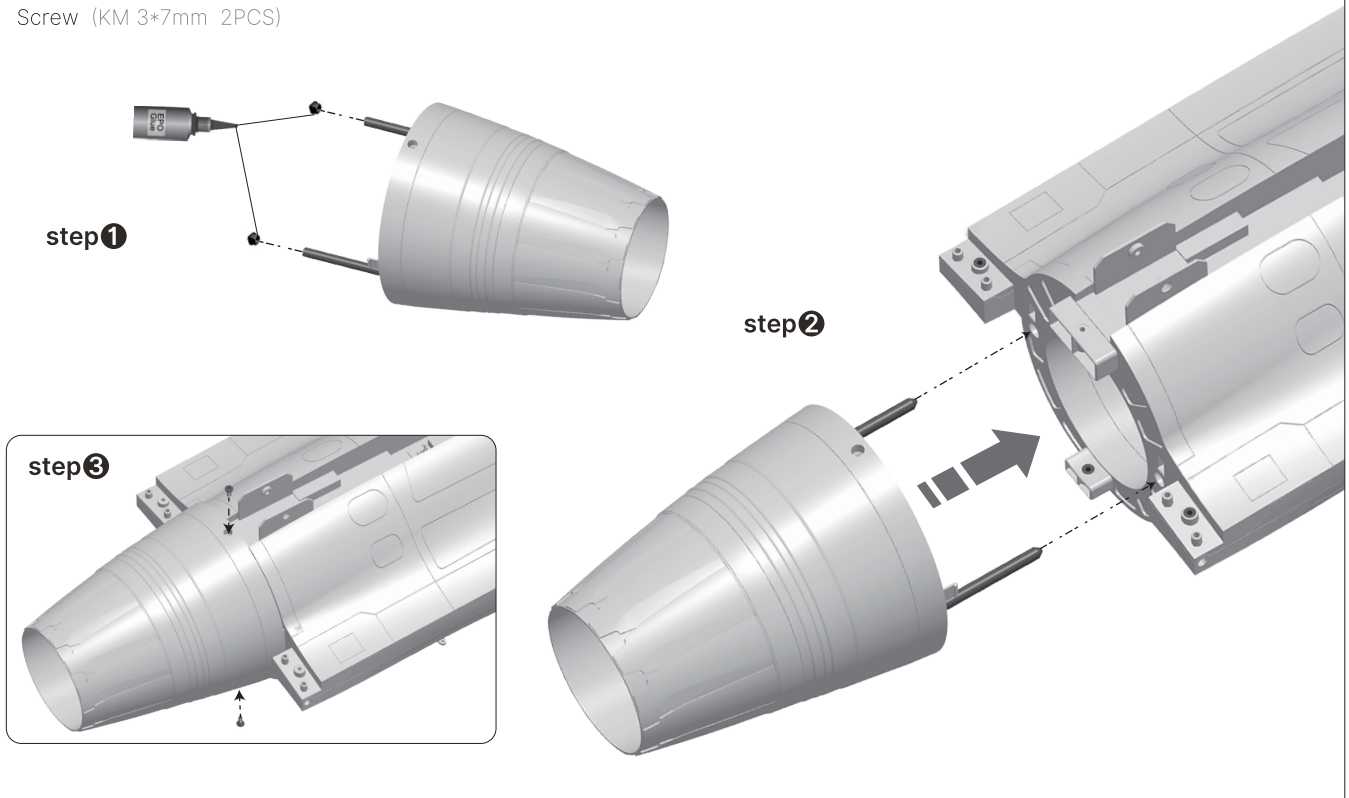

Install Speed brake

As the photo show:

1. Place the speed brake on the fixing hole of fuselage and secure it with screws to prevent it from falling off.

Screw (KM 3*7mm 2PCS)

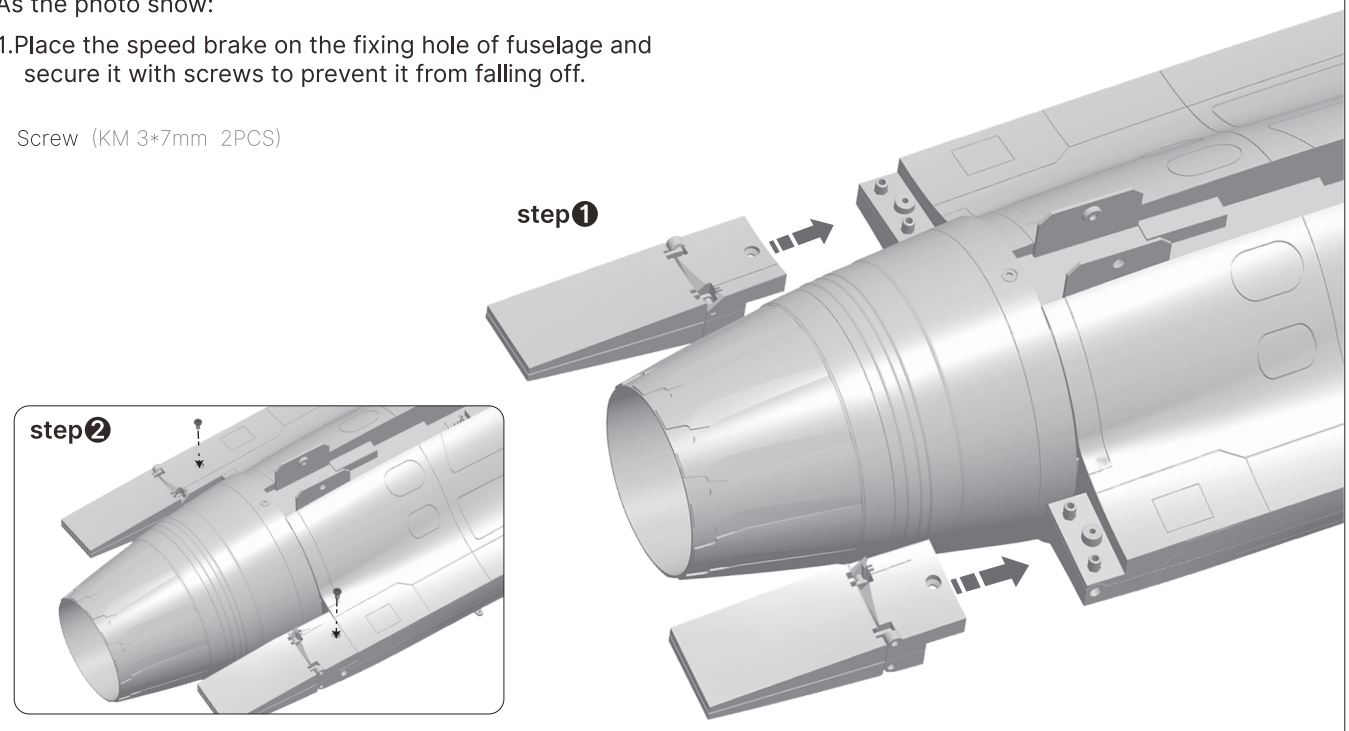

Install the Horizontal tail

As the photo show:

1. Flip the fuselage with the belly facing upwards; Insert the elevator rotating shaft into the fuselage until it reaches the bottom, and then fix it with two screws to prevent it from falling off.
2. Put the elevator fixing ring (screw hole facing upwards) into the elevator installation groove; Wrap it together with the horizontal tail on the rotating shaft at the end of the fuselage until it reaches the bottom.
3. Screw the screw into the locking hole on the fixing ring to prevent the horizontal tail from falling off. (First, lock the screw into the horizontal tail fixing ring, and then place it into the horizontal tail installation slot for easier installation.)
4. Repeat the above steps and install the other side with a horizontal tail.

Screw ①(KA3*10mm 4PCS) ② (M3*3mm 2PCS)

⚠ Attention: The diameter of the screw here is small, and it can be tightened slightly during the tightening process. Do not use excessive force to cause the screw to slip.

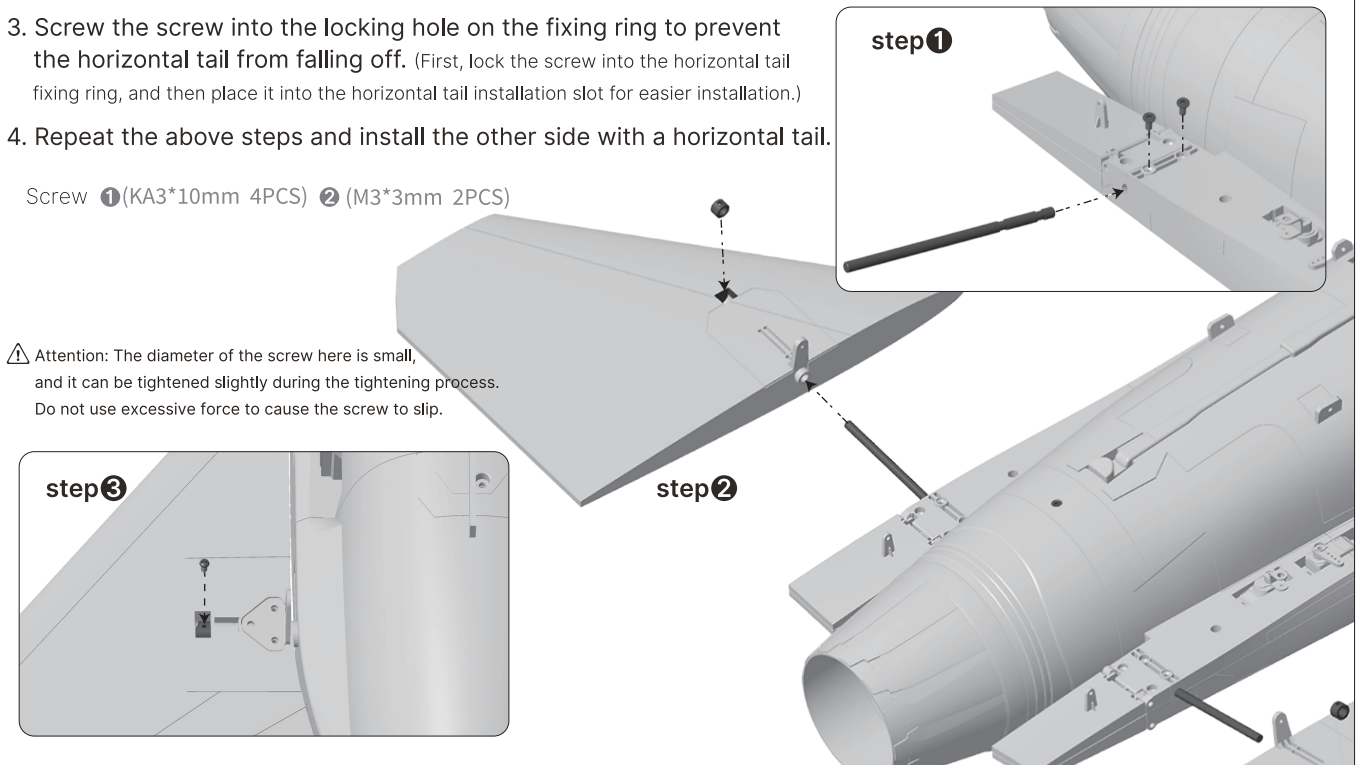

Install the Vertical tail

As the photo show:

1. Insert the rudder servo wire and LED light wire onto the tail wing control board;
2. After installed the vertical tail onto the fuselage, tighten it with four screws.

Screw (KM 3*7mm 4PCS)

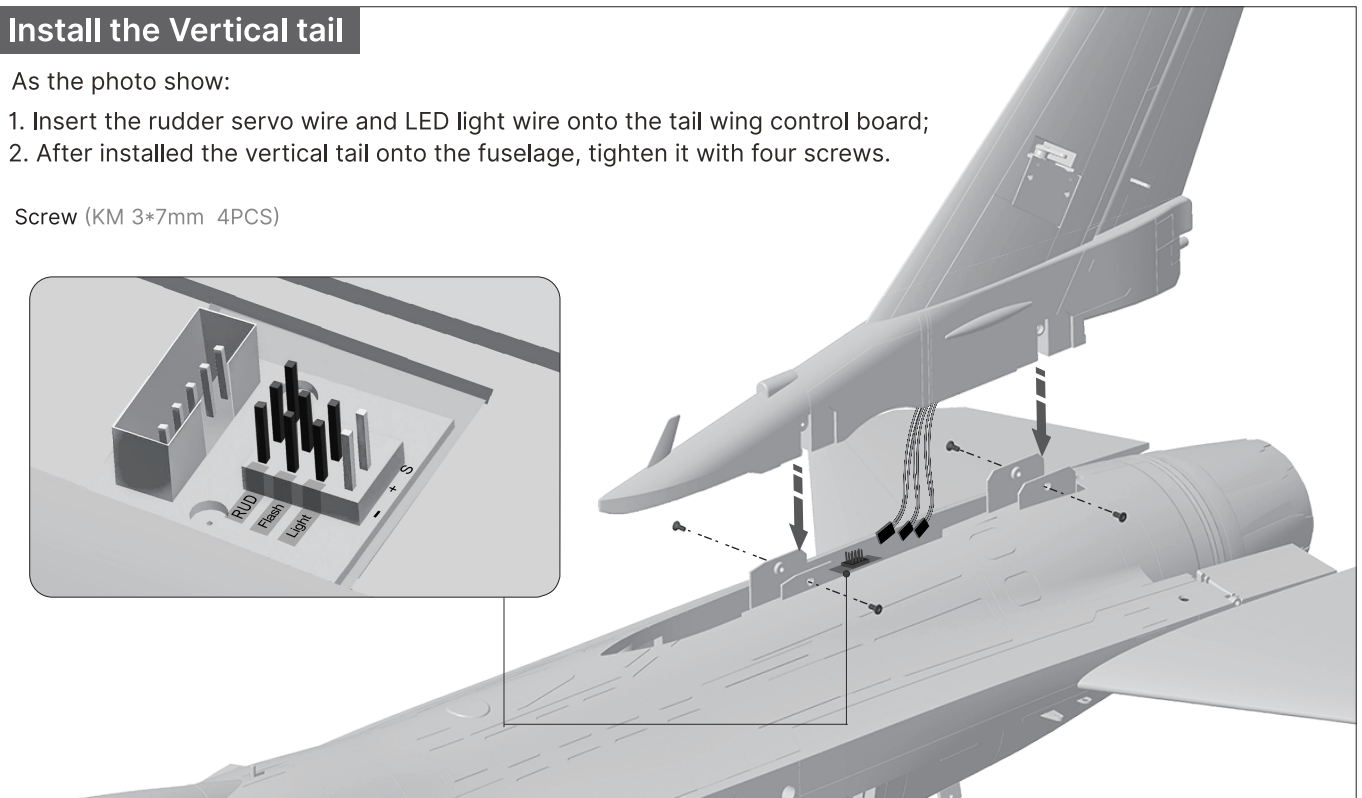
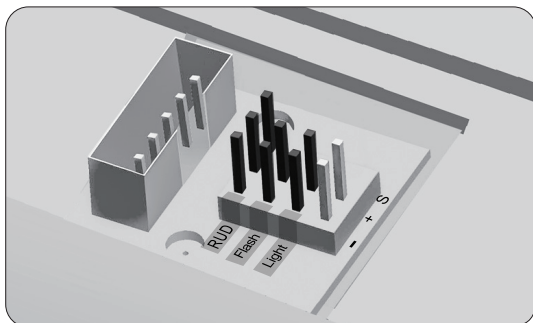

Install the Main Wing

As the photo show:

1. Use glue to fix the **Conical plastic part** on two carbon tubes respectively;

Carbon tube ①(Ø8*600mm 1PCS) ②(Ø8*400mm 1PCS)

Conical plastic parts (Ø8mm 4PCS)



2. Install the carbon tube on the fuselage;
3. Align the carbon tube on both sides with the main wing, connect the cables to the main wing control board, and push the main wing into the installation position on the fuselage;
4. When a slight "click" sound is heard, it indicates that the main wing has been installed;
5. Check and confirm that the latch lever on the lower surface of the main wing has been reset and locked^① (repeat this step for the other side of the main wing)

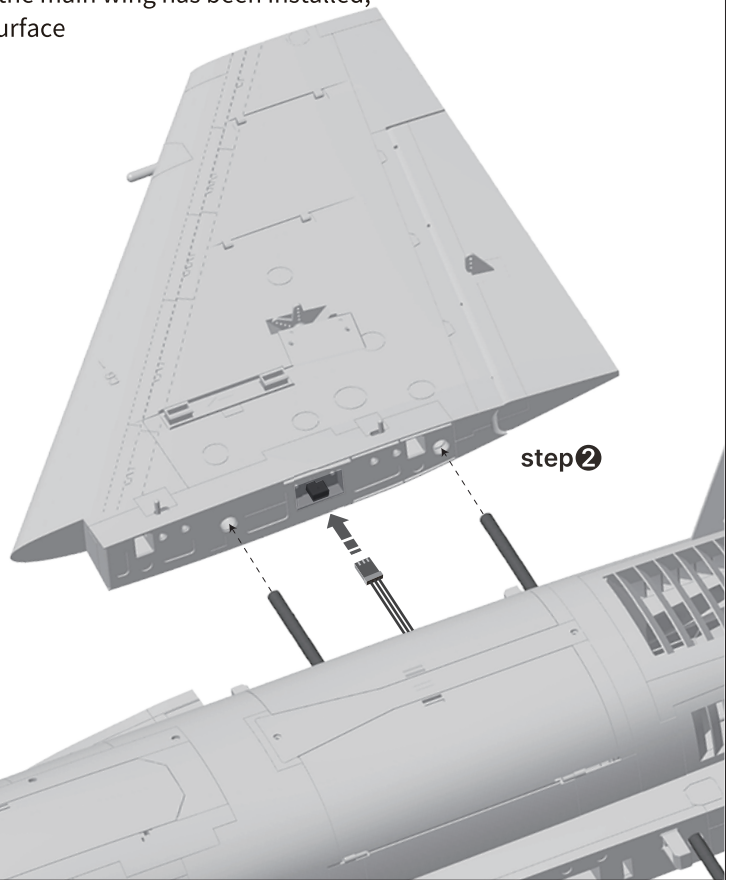
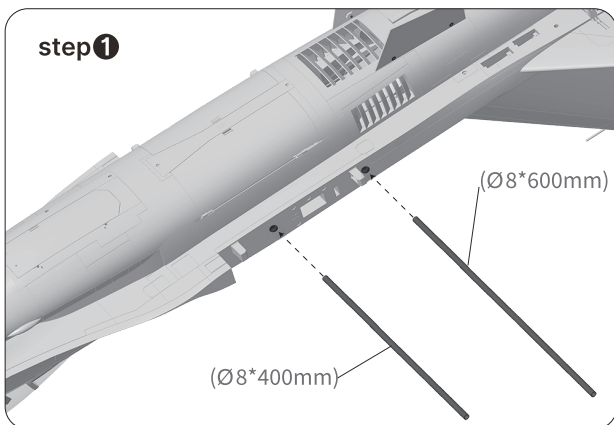

- ① Three different states of the latch toggle lever is as the photo shown:

Latch toggle lever lock status

As the photo show, the front/rear lever is in outside end point

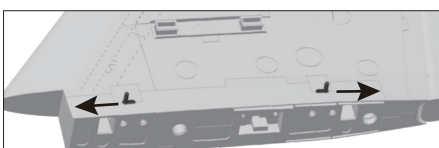

When unlocking, it is necessary to manually push the front and rear toggle levers towards the middle at the same time.

Latch toggle lever unlock status

As the photo show, the front/rear lever is in inside end point

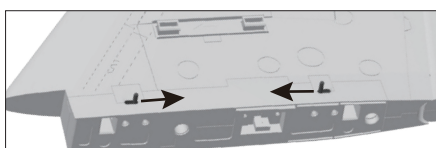

The latch toggle lever abnormal status

As the photo show, the front/rear lever is not in outside or inside end points

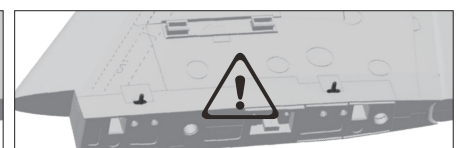

After installed the main wing, please check carefully. If happen the abnormal status, it is necessary to manually push the latch toggle lever to reset.

Install nose cone

As the photo show:

1. Insert the airspeed tube directly into the nose cone;
2. Refer to the diagram on the right and insert the sensor simulation component into the nose cone with glue;
3. Install the nose cone onto the fuselage

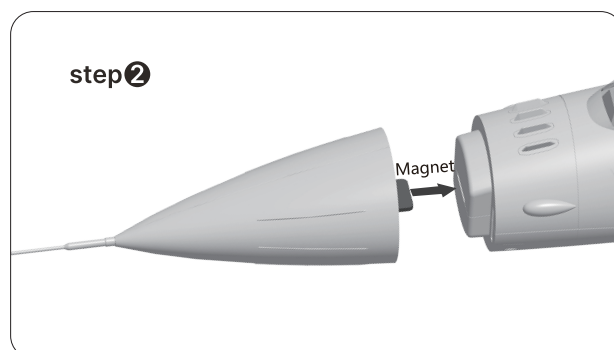
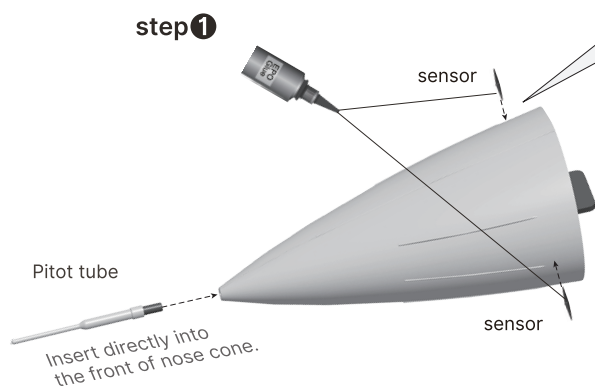
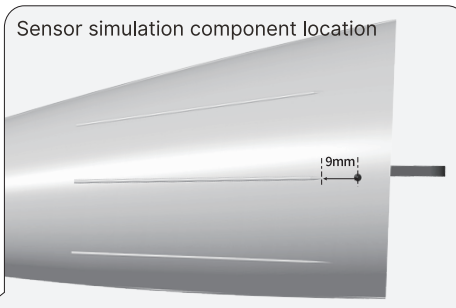

Install the pylons with screws on the main wing. The auxiliary fuel tanks and missile are both fixed with plastic slide rail structures, as shown in the picture below, and installed in designated positions.

Install missiles

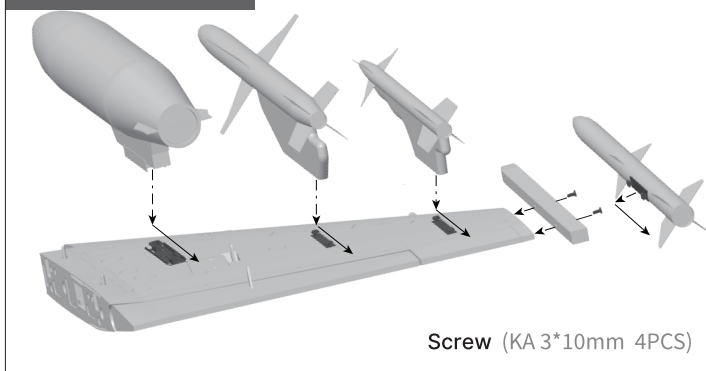

Install the fins

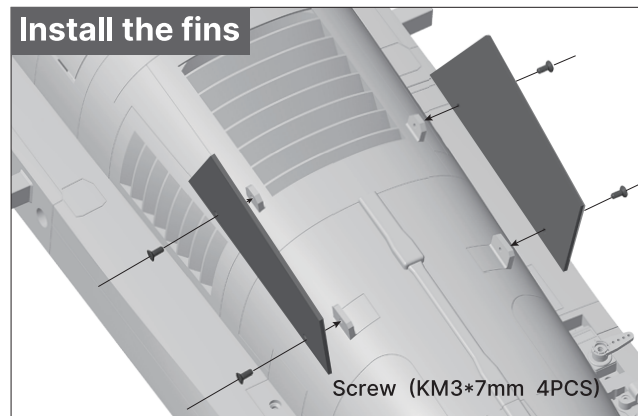

Install other accessories

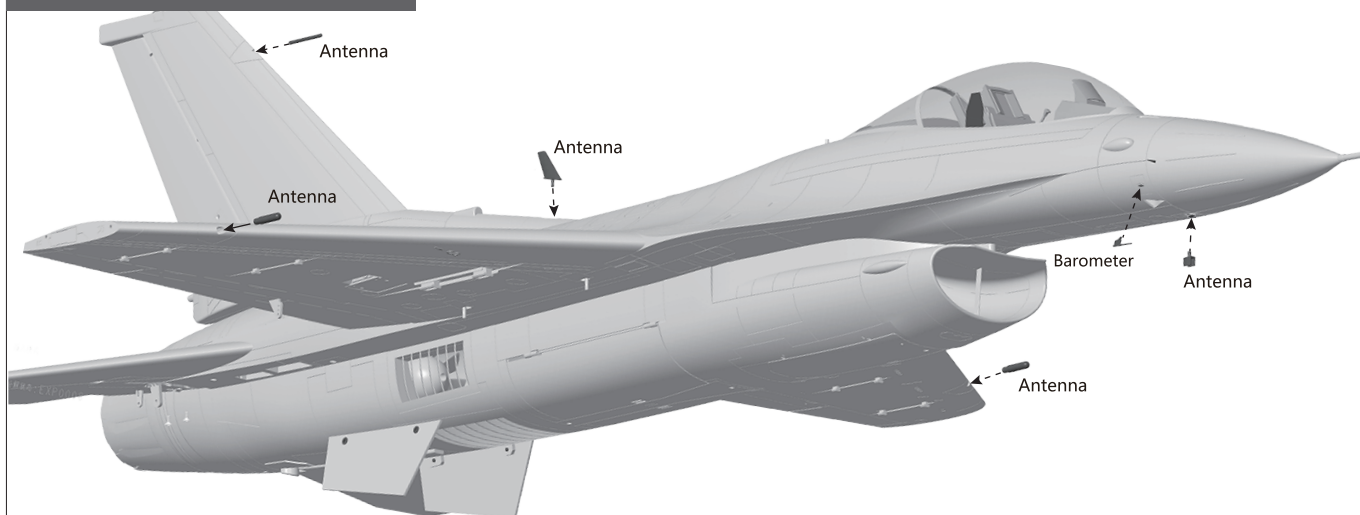

Install Battery

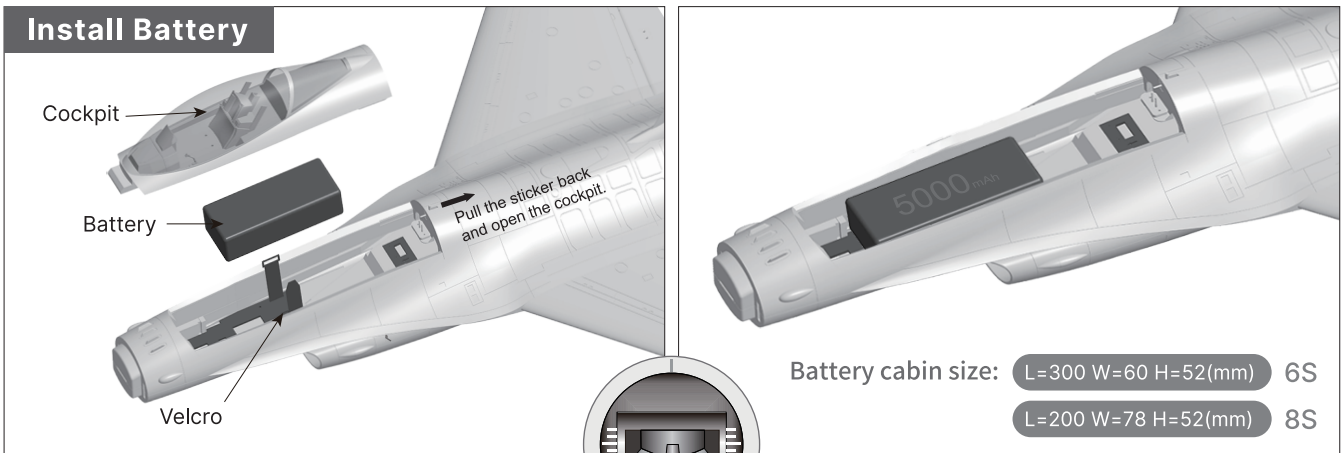

Battery cabin size: L=300 W=60 H=52(mm) 6S
L=200 W=78 H=52(mm) 8S

Before connecting the battery and receiver, please switch on the transmitter power and make sure the throttle stick is in the lowest position. Bind your receiver to your transmitter according to your transmitter's instruction manual.

We recommend the following LiPo battery:
6S 22.2V 5000mAh~6S 22.2V 6000mAh (1pcs)
8S 29.6V 4500mAh~8S 29.6V 5500mAh (1pcs)
Discharge rate of C ≥35C

Pushrod instructions

Aileron pushrod length

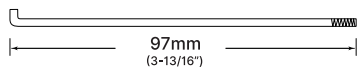

Pushrod diameter Ø1.5mm

Aileron pushrod mounting hole

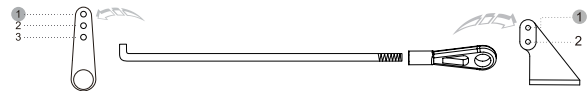

Rudder pushrod length

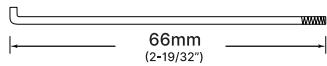

Pushrod diameter Ø1.5mm

Rudder pushrod mounting hole

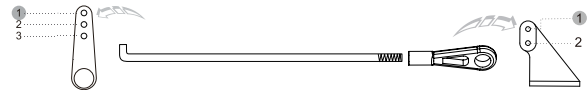

Elevator pushrod length

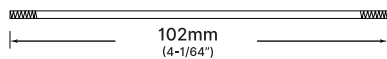

Pushrod diameter Ø2.0mm

Elevator pushrod mounting hole

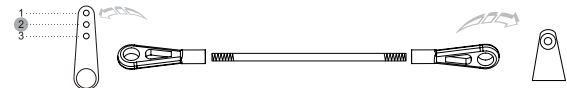

Nose Cabin door pushrod length

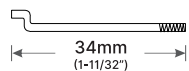

Pushrod diameter Ø1.2mm

Nose cabin door pushrod mounting hole



Rear cabin door pushrod length

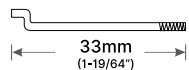

Pushrod diameter Ø1.2mm

Rear cabin door pushrod mounting hole



Speed brake pushrod length

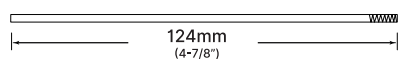

Pushrod diameter Ø1.2mm

Speed brake pushrod mounting hole



Nose gear steering pushrod length

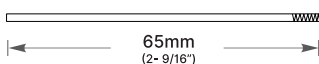

Pushrod diameter Ø1.5mm

Nose gear steering pushrod mounting hole



Important additional notes

The Y-type clevis used in this product is equipped with a transparent silicone ring for secondary reinforcement, which can effectively prevent the clevis from accidentally loosening.

As shown in the following figure, when you buckle the clevis into the control surface horn, use the silicone ring to cover the clevis.

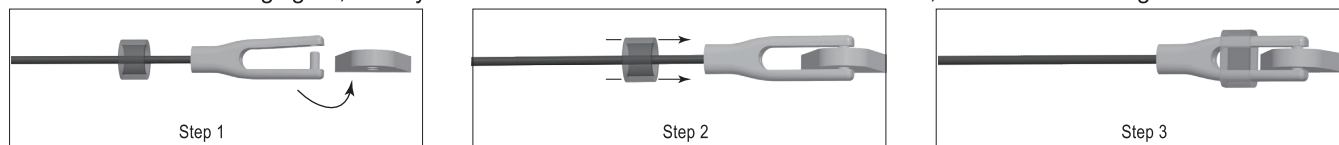

Center of Gravity

Correct Center of Gravity ("CG") is critical for enabling safe aircraft stability and responsive control. Please refer to the following CG diagram to adjust your aircraft's Center of Gravity.

- Depending on the capacity and weight of your chosen flight batteries, move the battery forward or backward to adjust the Center of Gravity.
- If you cannot obtain the recommended CG by moving the battery to a suitable location, you can also install a counterweight to achieve correct CG. However, with the recommended battery size, a counterweight is not required. We recommend flying without unnecessary counterweight.

As the photo show, We marked the center of gravity on the bottom of the Main wing. Please confirm the CG based on this marked position.

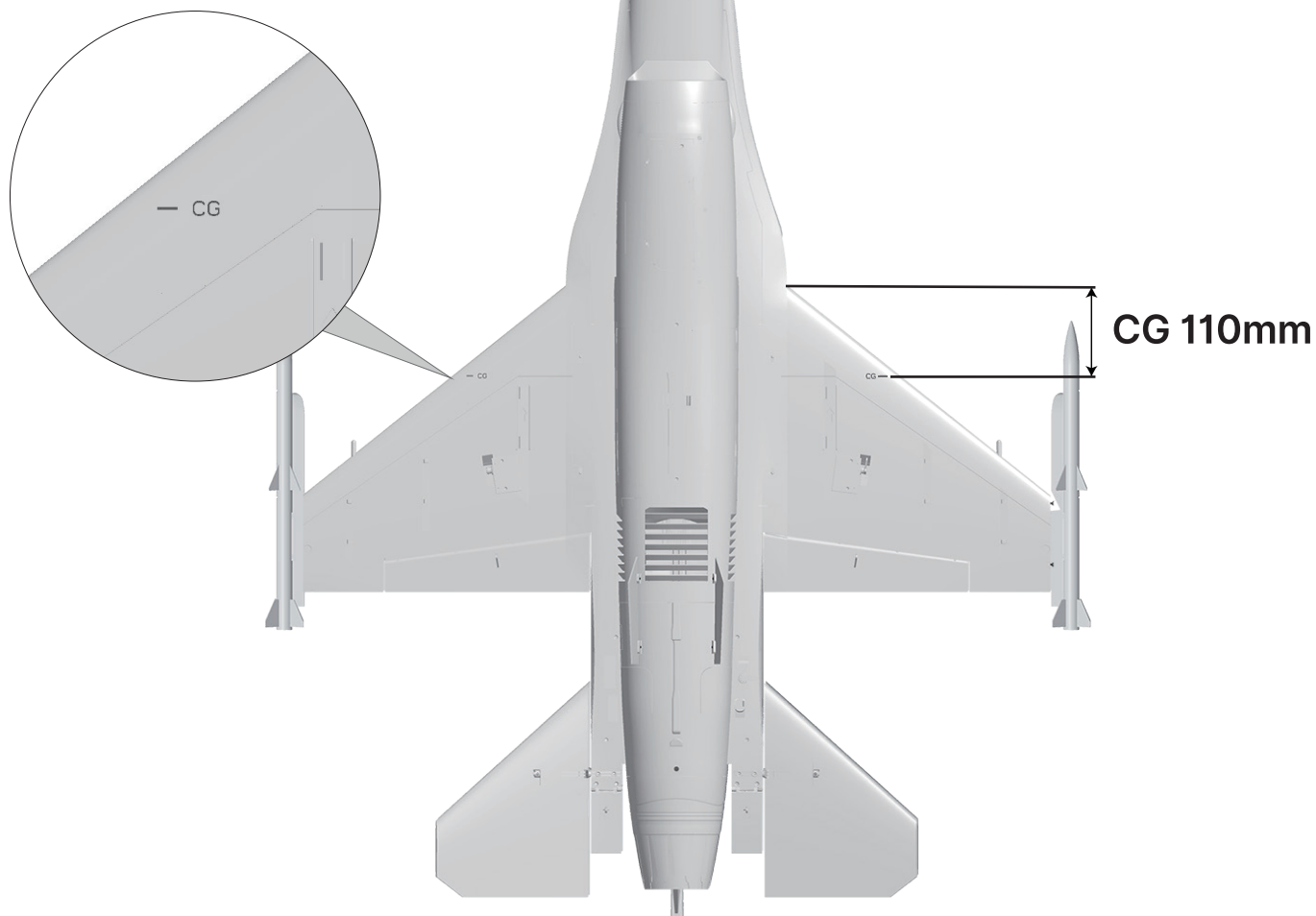

After installed this F-16 model plane, please connect to the receiver and power on, then adjust it.

1. When all channels of radio are fine tuned to zero and the control stick is centered: check whether each control surface on the aircraft is in the center position. If it is found that the control surface is not in the center position, please adjust the control rod to center it;
2. Please refer to the diagram below and use the radio to test each control surface to ensure that its movement direction matches the diagram. If the opposite movement occurs, first check whether the relevant channel in the radio has enabled the reverse function; If the problem persists, please contact us for assistance in resolving it.

Aileron

Stick Left

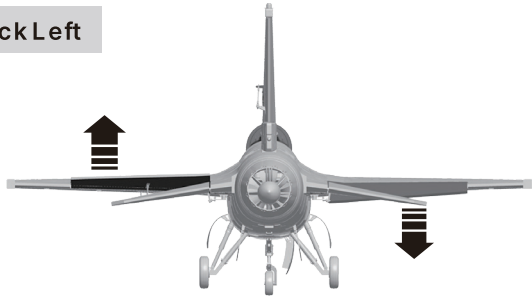

Stick Right



Rudder

Stick Left



Stick Right



Elevator

Stick down

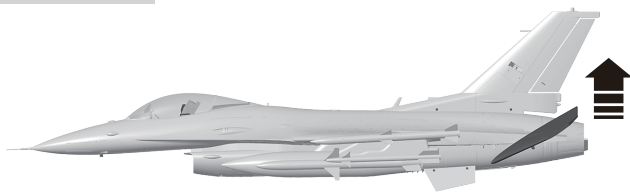

Stick up

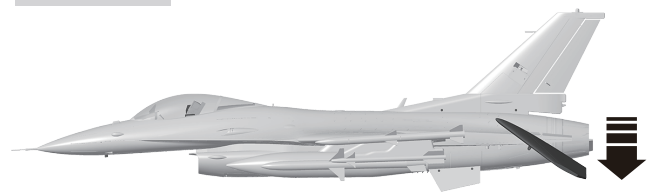

Remote Control EXP Setting Suggestion

1. Aileron EXP curve is shown as below :

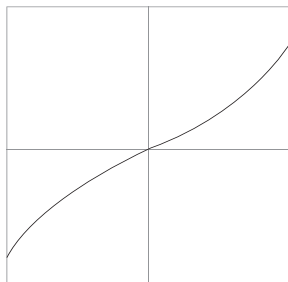

Futaba brand Remote Control : EXP A -30
EXP B -30

Spektrum brand Remote Control : EXPO 30% 30%

2. Elevator EXP curve is shown as below :

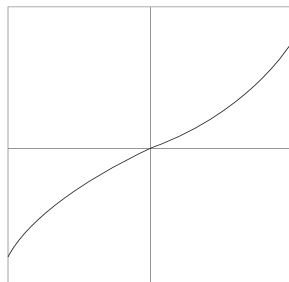

Futaba brand Remote Control : EXP A -30
EXP B -30

Spektrum brand Remote Control : EXPO 30% 30%

3. Rudder EXP curve is shown as below :

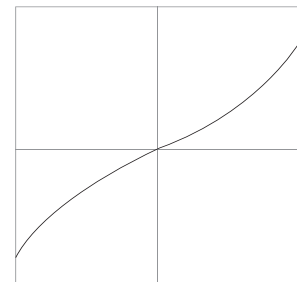

Futaba brand Remote Control : EXP A -30
EXP B -30

Spektrum brand Remote Control : EXPO 30% 30%

Dual Rates

According to our testing experience, use the following parameters to set Aileron/Elevator Rate. Program your preferred Exponential % in your radio transmitter. We recommend using High Rate for the first flight, and switching to Low Rate if you desire a lower sensitivity. On successive flights, adjust the Rates and Expo to suit your preference.

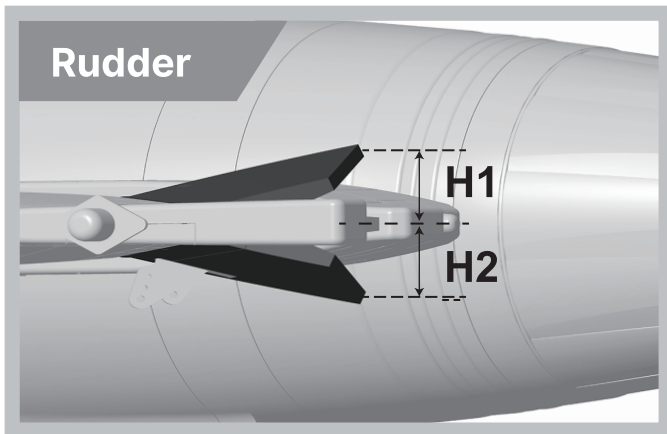
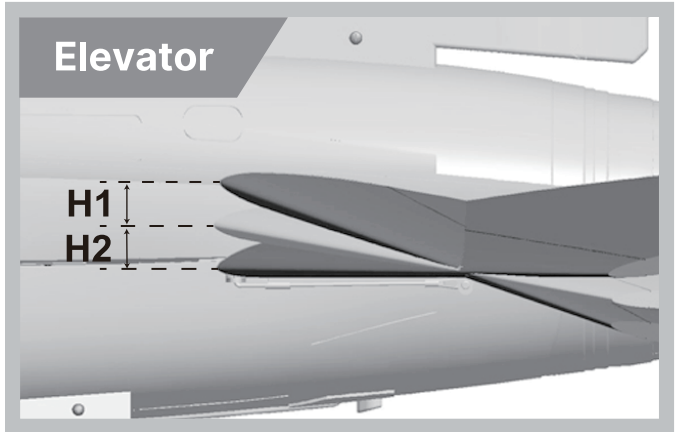
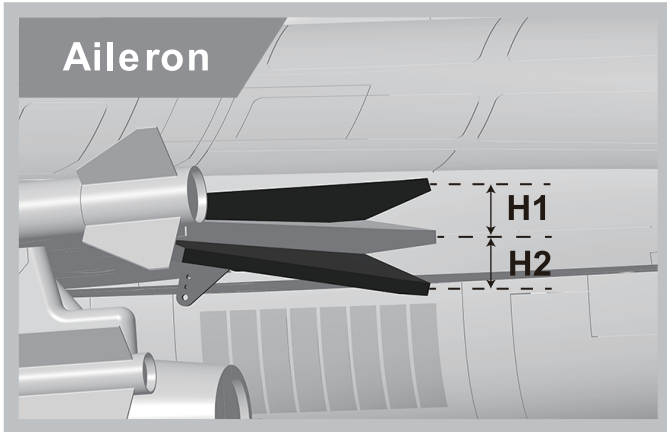

	Aileron (Measured closest to the fuselage)	Elevator (Measured closest to the fuselage)	Rudder (Measured from the bottom)
Low Rate	H1/H2 28mm/28mm D/R Rate: 80%	H1/H2 28mm/28mm D/R Rate: 80%	H1/H2 24mm/24mm D/R Rate: 80%
High Rate	H1/H2 35mm/35mm D/R Rate: 100%	H1/H2 33mm/33mm D/R Rate: 100%	H1/H2 28mm/28mm D/R Rate: 100%

Important Flight Notes:

1. Please refer to the right photo and adjust the elevator to the correct center position.

Distance from the leading edge of the horizontal tail root (at the forefront position) to the upper surface of the fuselage: 19mm

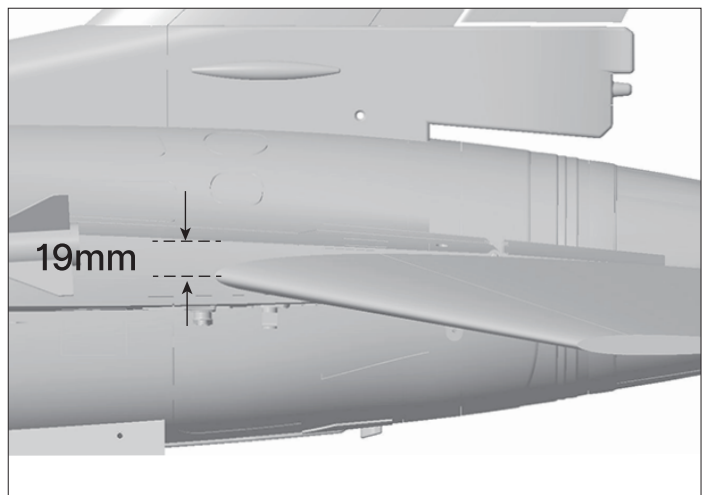

Servo Direction

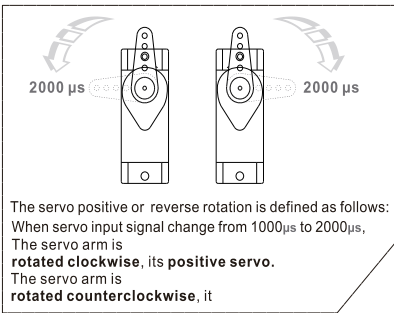

If you need to purchase another brand's servo, please refer to the following list to choose a suitable servo.

Position	Servo regulation	No.	Pos. / Rev.	Cable length
Nose gear steering servo	9g Digital-Hybrid	1	Positive	200mm
Nose cabin door	9g Digital-Hybrid	2	Reverse	200mm
rear cabin door (L)	9g Digital-Hybrid	3	Positive	200mm
rear cabin door (R)	9g Digital-Hybrid	4	Reverse	200mm
Aileron(L)	17g Digital-MG	5	Positive	200mm
Aileron(R)	17g Digital-MG	6	Positive	200mm
Rudder	17g Digital-MG	7	Positive	200mm
Elevator(L)	23g Digital-MG	8	Positive	100mm
Elevator(R)	23g Digital-MG	9	Reverse	100mm
Speed brake(L)	9g Digital-Hybrid	10	Positive	100mm
Speed brake(R)	9g Digital-Hybrid	11	Reverse	100mm

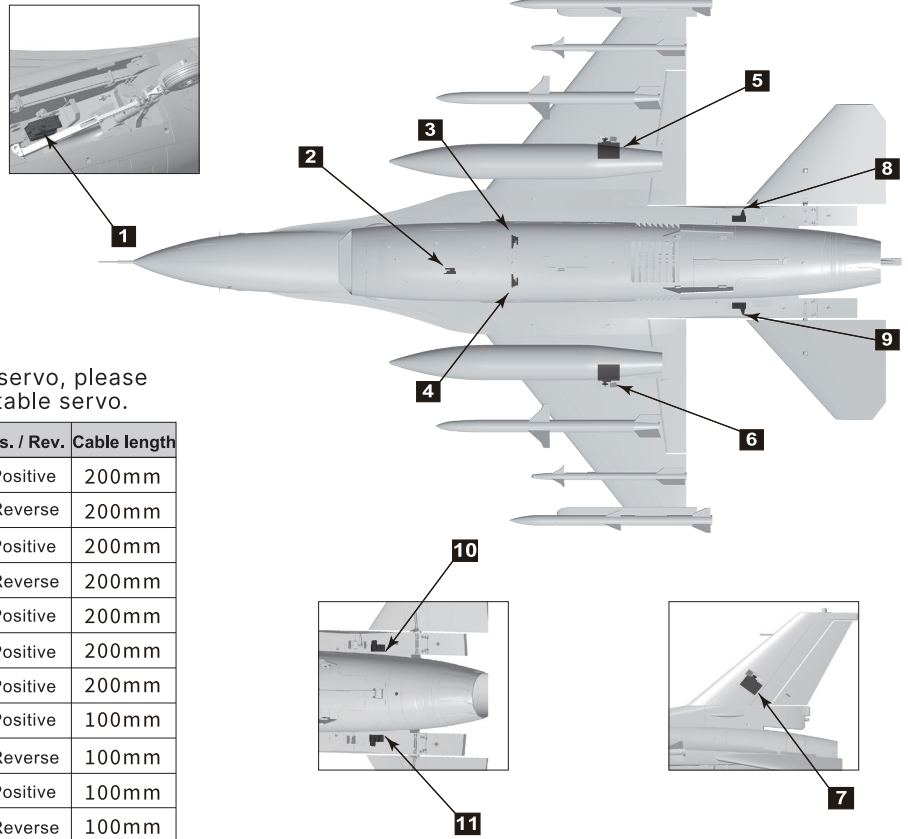

Motor Specification

3668-1960
 Item No.:MI036681

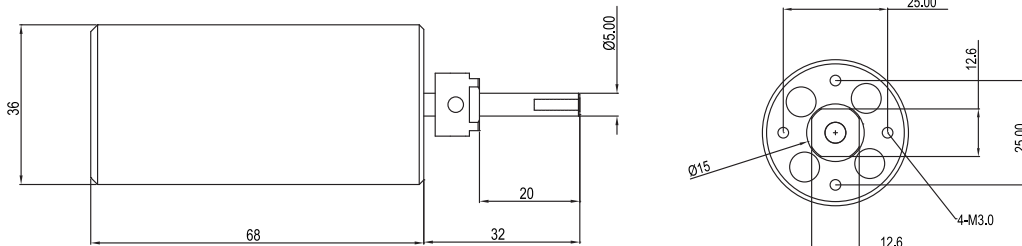

6S

3668-1960KV

Item No.	EDF Fans	Use voltage (V)	Current(A)	Max power (W)	Thrust(g)	Efficiency (g/w)	Motor(KV)	Use ESC (A)	Weight (g)
E72216	90mm 12-Blade	22.2	120	2660	3700	1.4	3668-1960	120	454

Item No.:MI040754
4075-1350kv

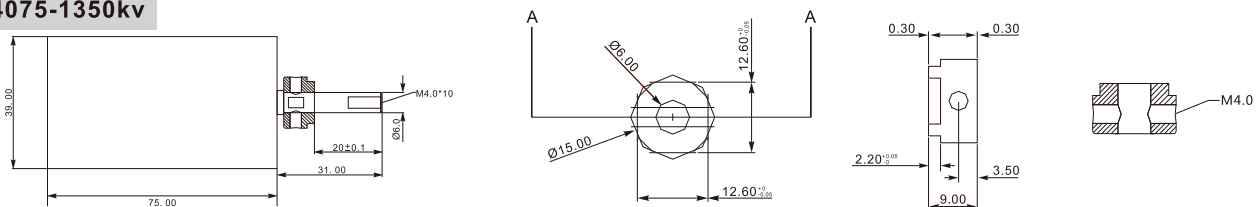

8S

Unit :mm

Item No.	EDF Fans	Use voltage (V)	Current(A)	Max power (W)	Thrust(g)	Efficiency (g/w)	Motor(KV)	Use ESC (A)	Weight (g)
E72215	90mm 12-Blade	29.6	115	3400	4700	1.39	MI040754 4075-1350KV	120	558

欢迎您购买飞翼90系列F-16C“战隼”V2版模型飞机。在您组装这架飞机前，请认真阅读说明书和组装视频，按照正确的方式进行组装、设定与调试。在此过程中，如遇特殊问题且无法自行解决的，请立即联系经销商，或直接联系我们，寻求帮助。

新的F-16C“战隼”模型飞机V2版本尺寸并未改变，依旧采用1/10比例制作。翼展955mm，机长1457mm，EPO为主要机体制作材料。不过，其95%的零部件，均使用新的模具制造。相比旧版本，宛如脱胎换骨，实现了飞跃性的升级。V2版本的F-16C，与前一代相比，有以下改进及优化内容：

- | | |
|------------------|---------------------|
| -新的迷彩涂装 | -挂载类（含副油箱）采用导轨式快拆结构 |
| -增加边条翼塑料保护罩 | -前、后机身快拆 |
| -增加电池舱边沿塑料保护罩 | -增加电动仿真减速板 |
| -增加机翼边角保护罩 | -增加隐藏式机背进气道 |
| -增加机体刻线及铆钉细节 | -增强起落架固定座结构强度 |
| -起落架外形调整 | -舱门更改为模具制作的塑料舱门 |
| -起落架喷漆上色 | -仿真LED灯组 |
| -其它细节位置塑料件的运用 | -改进后的V2版座舱插销 |
| -可选配的仿真仪表台及仿真座椅 | -增加电池舱空间，适应8S电池 |
| -采用QUICK一代主翼快拆系统 | -气动性能优化 |

由此可见，全新V2版本的F-16C模型飞机，不仅仅拥有更加精致的外观，还将给我们带来更便捷的操作体验、以及更好的飞行感受。在动力方面，将有二个版本可以选择：

6S标准版，搭载E72216动力组（3668-1960KV内转电机，12叶塑料涵道），120A无刷电调。最大平飞速度185KPH
8S升级版，搭载E72215动力组（4075-1350KV内转电机，12叶金属外框涵道风扇），120A无刷电调。最大平飞速度210KPH，动力强劲、拥有极强的长时垂直爬升能力！

飞翼F-16C“战隼”V2版本，进一步优化了飞机的气动性设计，飞行过程中，拥有非常好的稳定性，较旧版本，飞行品质有了较大提升。新的起落架，不仅在外形方面进行了改进，同时，对以往的问题进行统计、分析，作出了针对性的改进，使其更加坚固、耐用。新加入的电动减速板，能够有效降低飞行速度，可以更好地辅助降落。

再次感谢您，希望这款全新的重制V2版F-16C“战隼”，能够带给您更好地体验，预祝您首飞成功！

重要提示

- 1.模型飞机不是玩具,操作者需要具备一定的经验;没有经验的初学者,必须在有丰富经验的专业人士指引下,逐步学习!
- 2.在组装之前,必须认真阅读产品说明书,严格按照说明书指示操作。
- 3.飞翼模型及其销售商,对于违反说明书的要求操作而造成的损失、将不负任何法律责任!
- 4.模型飞机的使用年龄必须是14岁以上的儿童或者成人。
- 5.此模型产品使用EPO材料制成,表面喷涂油漆,不可随意使用化学制剂擦拭,否则会损坏模型产品。
- 6.不可以公共场合、高压线密集区、高速公路附近、机场附近或者其它法律法规明确禁止飞行的场合飞行。
- 7.不可以雷雨、大风、大雪或者其它恶劣气象环境下飞行。
- 8.模型飞机的电池产品,不可以随意乱扔,乱放。存放时,必须保证周边2M范围内,无易燃、易爆物体。
- 9.损坏或者报废处理的模型飞机电池,应妥善回收处理,不准随意抛弃,避免自燃而引发火灾。
- 10.在飞场飞行时,应做到妥善处理飞行后所产生的垃圾,不可随意抛弃、焚毁模型及其配件。
- 11.在任何情况下,都必须保证油门杆处于起始位、发射机处于打开状态时,才能连接模型飞机内部的动力电池。
- 12.无论是模型飞机是在正常飞行过程中,或者是在缓慢降落过程中,都不要尝试用手去回收模型。必须等模型降落停稳以后,再进行回收!

⚠ 注意：模型产品是具有一定危险性的产品，请禁止14岁以下的儿童玩耍，14岁以上的儿童，请在有飞行经验的成人指导下使用，无飞行经验的购买者，应当在具有一定电动涵道飞机飞行经验的成人指导下使用！组装模型前，请仔细阅读说明书，按照说明书的要求进行安装。进行调试和飞行时，请根据说明书指示的参数进行调整。



6S标准版

翼载荷: 205g/dm²
 翼面积: 18.8dm²
 舵机: 9g数字混合齿(6pcs)17g数字金属齿(3pcs)
 23g数字金属齿(2pcs)
 电机: 3668-1960KV内转无刷电机
 涵道风扇: 90mm 12叶涵道组
 电调: 120A无刷电调 (带反推刹车功能)
 重量: 3156g(不含电池、导弹/导弹: 184g)
 电池范围: 6S 5000-6000mAh
 起落架: 电动涡轮收放、铝合金减震组仿真装饰

8S升级版

电机: 4075-1350KV内转无刷电机
 涵道风扇: 90mm 12叶涵道组
 重量: 3300g(不含电池、导弹/导弹:184g)

其他说明

舱门: 前、后完整舱门、舵机控制
 航灯: 仿真LED航灯
 其他: 减速板
 仿真座舱3D打印套件 (另行选购)

注意: 此处各项参数,均使用本公司配件测试得出,如果使用副厂配件,会有所差异。使用副厂配件时所产生的问题,我们将无法给予技术支持!

产品包装清单

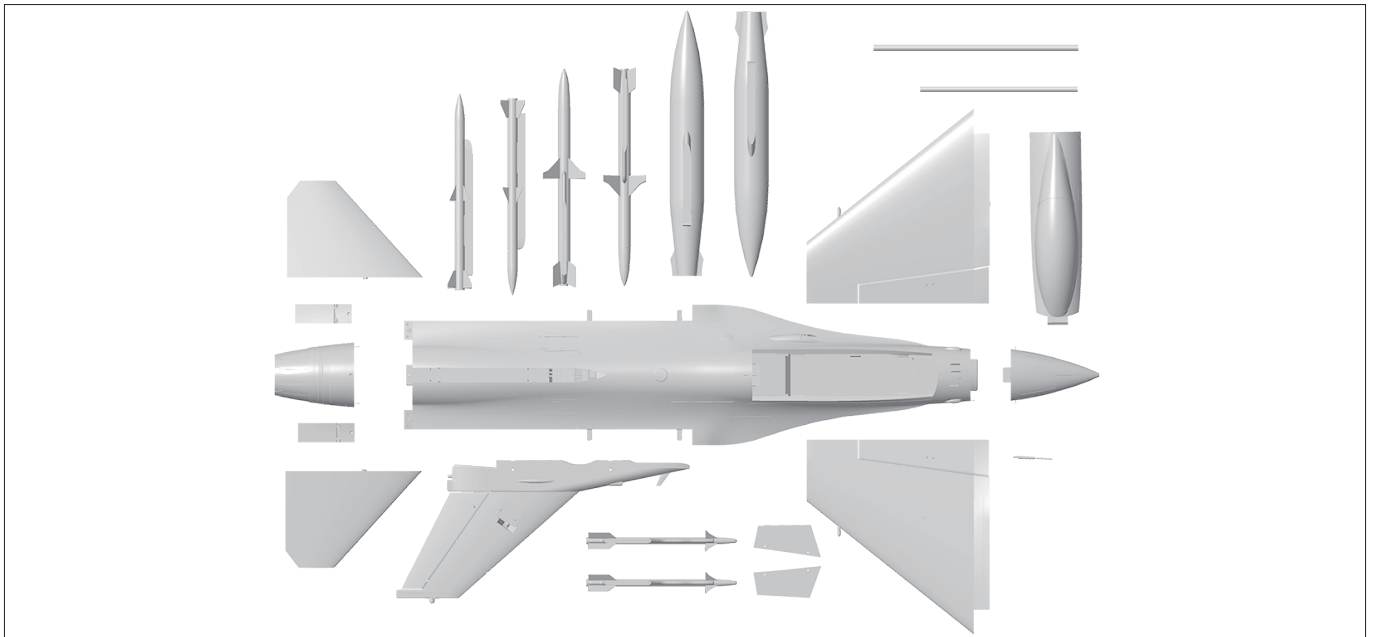

打开产品包装,核对包装清单。(不同配置的版本,包含内容不同!)

序号	配件名称	PNP	ARF Plus	序号	配件名称	PNP	ARF Plus
1	机身	预装所有电子设备	预装舵机	6	座舱、机头罩	✓	✓
2	主翼	预装所有电子设备	预装舵机	7	腹鳍、碳纤维管	✓	✓
3	平尾	预装所有电子设备	预装舵机	8	附件包	✓	✓
4	垂尾	预装所有电子设备	预装舵机	9	导弹	✓	✓
5	减速板	✓	✓	10	说明书	✓	✓

机身组装

如图所示：

- 1.使用胶水把【导向锥】分别固定在两条碳管上；
- 2.将碳管对准机身后，把后段机身推入到机身的安装位置上；
- 3.后段机身安装到机身后，用两颗螺丝紧固好。

螺丝 (KM 3*7mm 2PCS)

步骤①

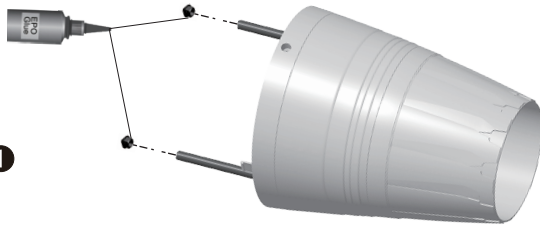

步骤②

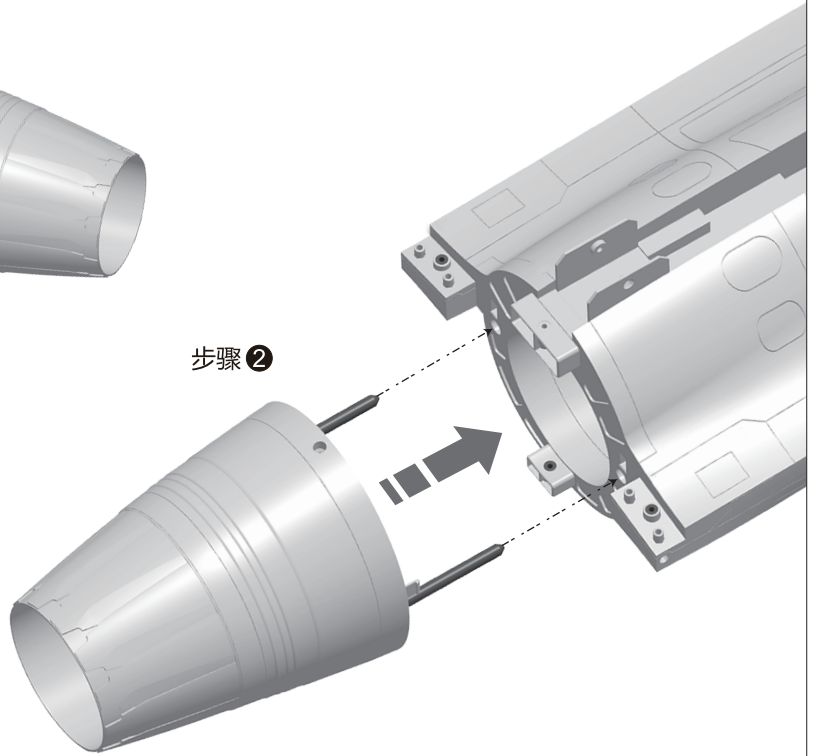

步骤③

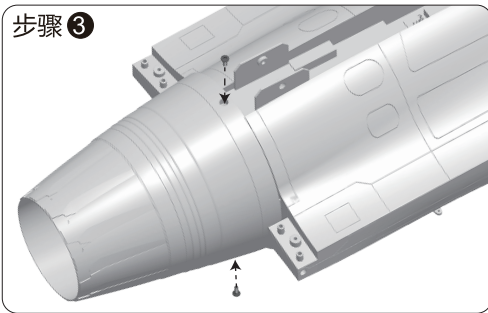

减速板组装

如图所示：

- 1.将减速板套在机身固定孔上，然后用螺丝固定，防止脱落。

螺丝 (KM 3*7mm 2PCS)

步骤①

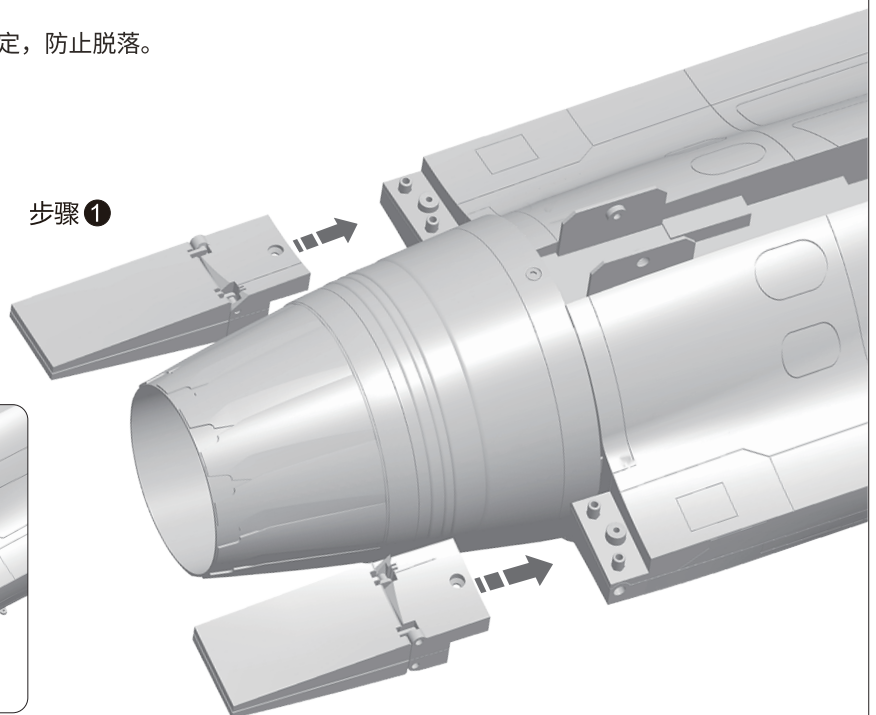

步骤②

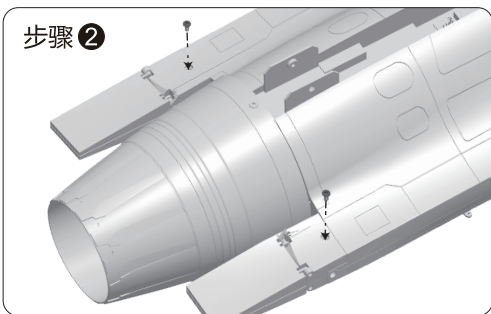

平尾组装

如图所示：

1. 翻转机身，机腹朝上；将平尾旋转轴插入机身直到底部为止，然后用两颗螺丝固定，防止脱落。
2. 将平尾固定圈(螺丝孔朝上)沉入平尾安装槽内；与平尾一并套在机身端旋转轴上,直到底部为止。
3. 螺丝从固定圈上的螺丝孔处拧入锁紧，防止平尾脱落。(先将螺丝锁入平尾固定圈，再放入平尾安装槽内更便于安装。)
4. 重复以上步骤，安装另一侧平尾。

螺丝 ① (KA3*10mm 4PCS) ② (M3*3mm 2PCS)

⚠注意：此处螺丝直径较小，紧固过程中稍微拧紧即可，切勿过度用力，造成螺丝滑牙。

步骤①

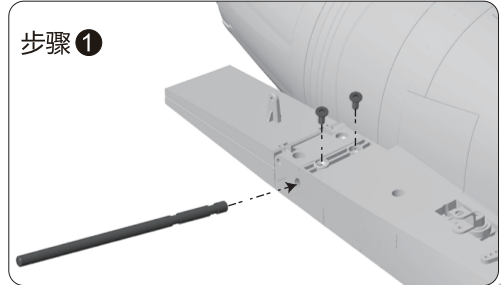

步骤②

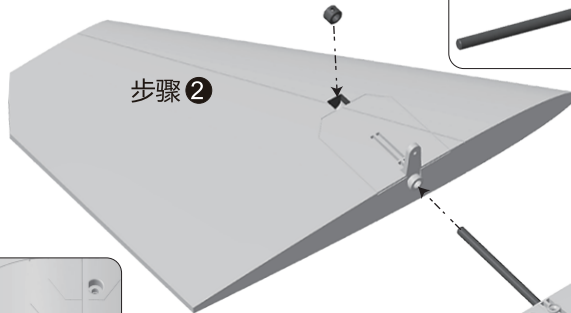

步骤③



垂尾组装

如图所示：

1. 将垂尾的舵机线与LED灯线插在尾翼转接板上；
2. 垂尾安装到机身后，用四颗螺丝紧固。

螺丝 (KM 3*7mm 4PCS)

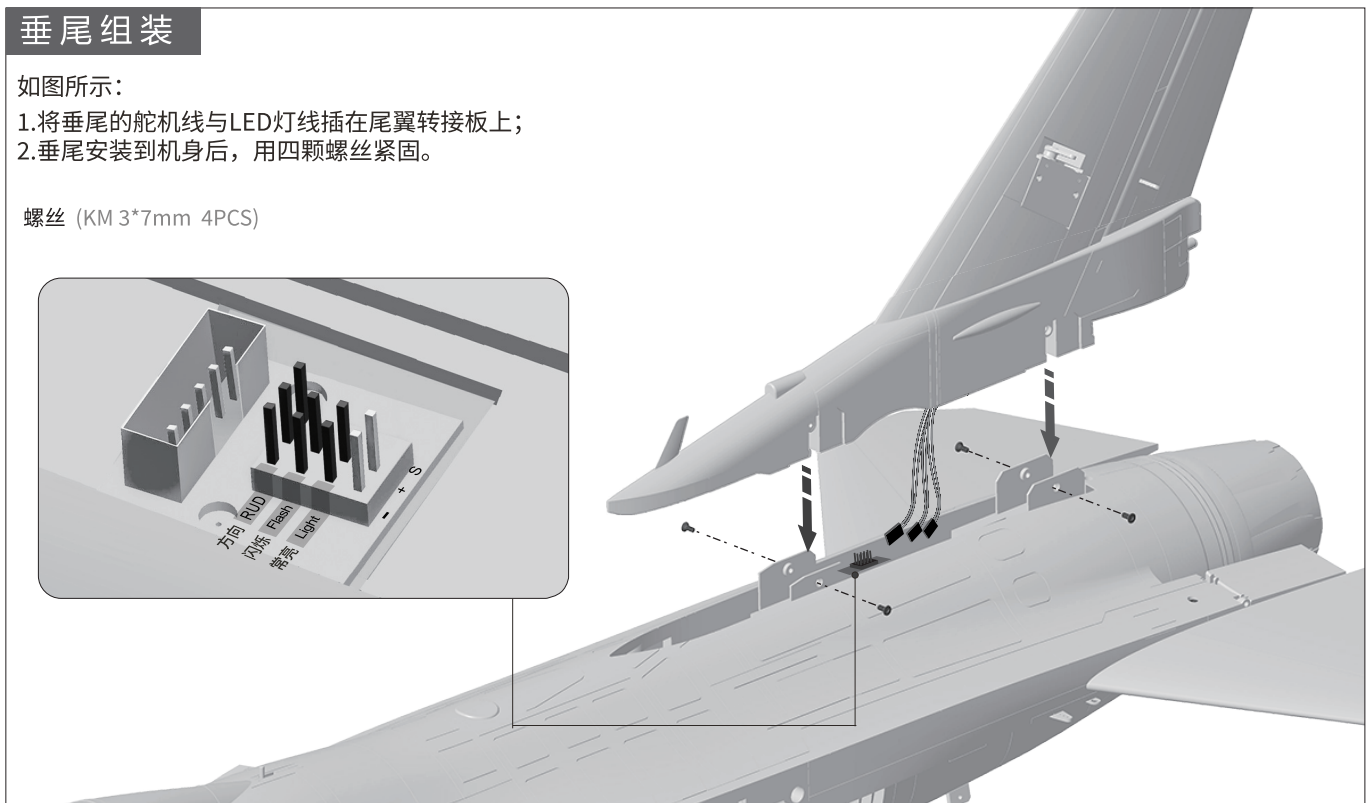
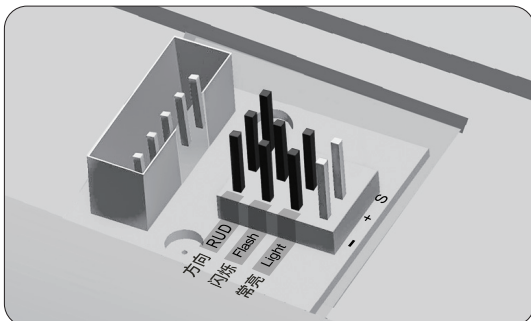

主翼组装

如图所示：

1.使用胶水把【导向锥】分别固定在两条碳管上；

碳纤管 ①(Ø8*600mm 1PCS) ②(Ø8*400mm 1PCS)

导向锥 (Ø8mm 4PCS)



- 2.把碳纤管安装在机身上；
- 3.将两侧碳管对准主翼，排线接入主翼侧面转接板后，把主翼推入到机身上的安装位置上；
- 4.当听到轻微“嗒”声后，证明已装好主翼；
- 5.检查确认主翼下表面插销拨动杆已处在锁止状态^①
(另一侧主翼重复此步骤)

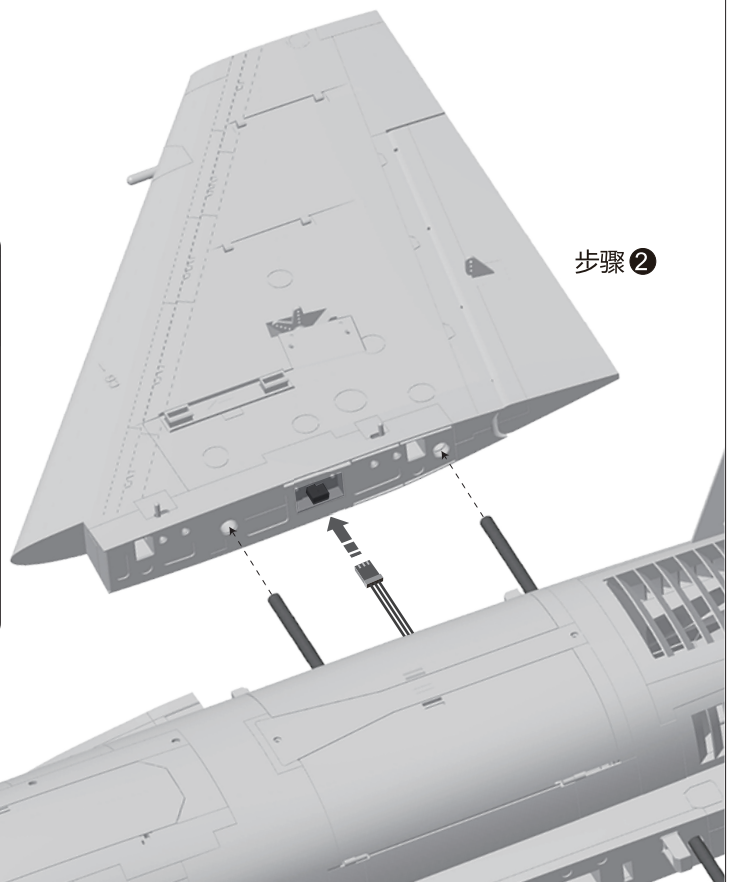
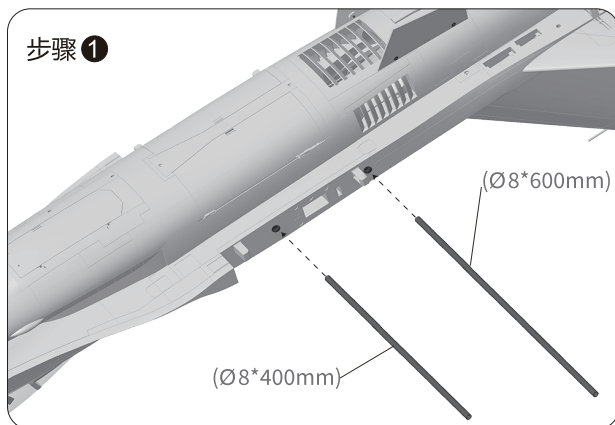

① 插销拨动杆三种不同状态图示：

锁止状态

如下图所示：

前、后插销拨动杆位置处于外侧

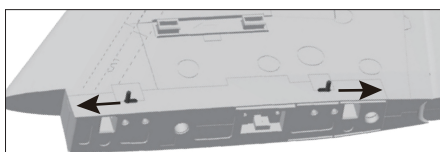

解锁时需要用手将前、后拨动杆同时推到另一端

解锁状态

如下图所示：

前、后插销拨动杆位置处于内侧

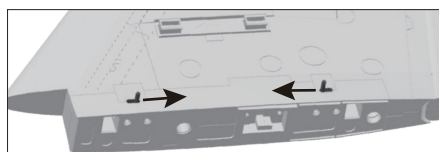

异常情况 ⚠

如下图所示：

插销拨动杆未处于前、后端点

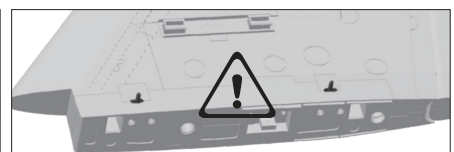

装好主翼后，请认真检查，如出现异常情况请用手推动插销拨动杆，让其处于正确锁止状态。

机头罩组装

如图所示：

- 1.将空速管直接插入机头罩前端；
- 2.参考右示意图，用胶水将传感器仿真件插入机头罩上；
- 3.把机头罩安装在机身上。

风标传感器位置示意图

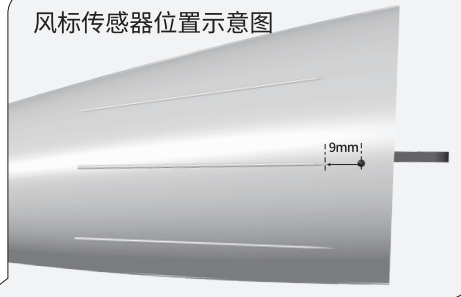

步骤①

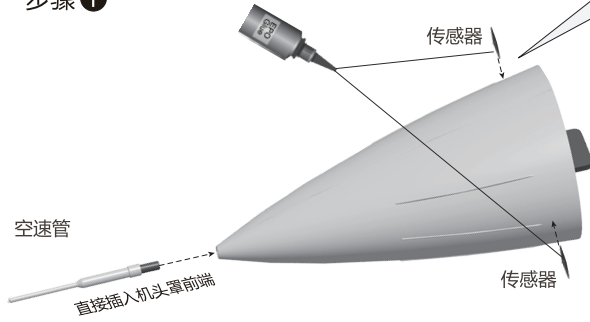

步骤②

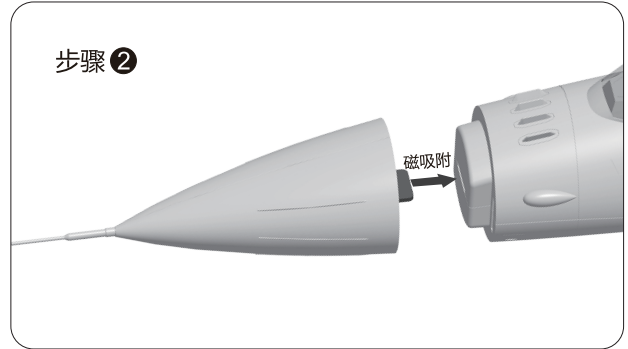

将挂架用螺丝安装在主翼上，副油箱、导弹均采用塑料滑轨结构固定，参考下面图片所示，将其分别安装到指定位置。

导弹组装

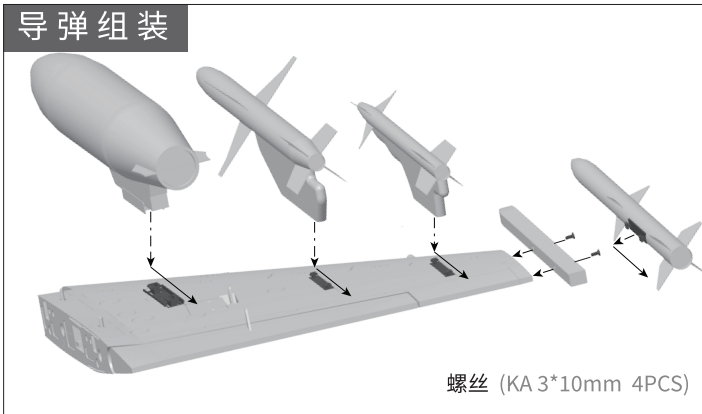

腹鳍组装

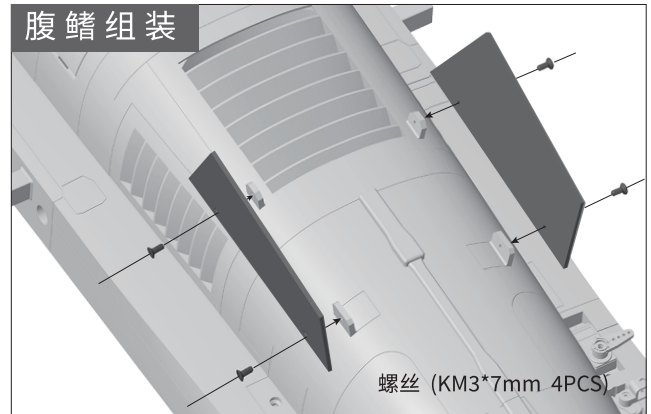

其它配件组装

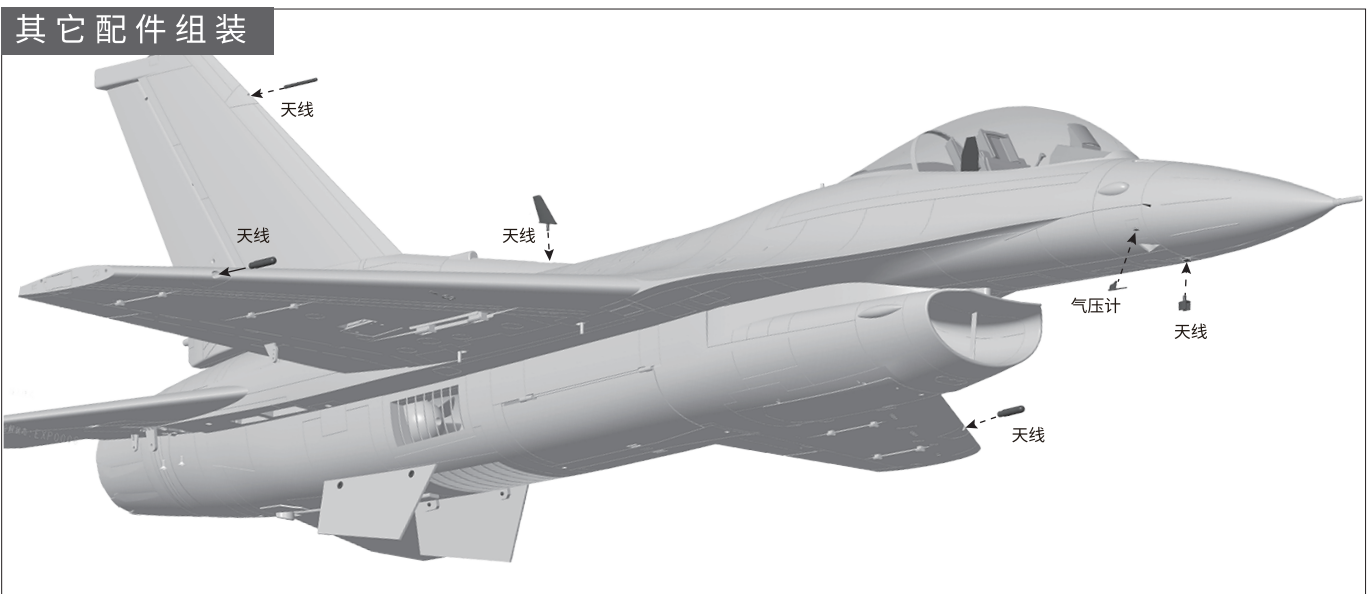

电池安装说明



将电池与电调连接前, 首先请打开发射机电源, 确认油门杆处于低位。
安装电池后, 启动油门前, 请保证没有任何物体在螺旋桨转动直径以内, 以免造成事故和人身伤害!

我们建议使用的电池容量和放电倍率如下:
6S 22.2V 5000mAh~6S 22.2V 6000mAh (1pcs)
8S 29.6V 4500mAh~8S 29.6V 5500mAh (1pcs)
放电倍率≥35C

舵面控制钢丝尺寸及安装孔位

副翼控制钢丝尺寸

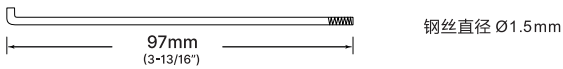

副翼控制钢丝安装孔位

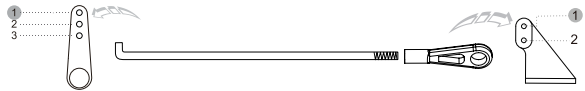

垂尾控制钢丝尺寸



垂尾控制钢丝安装孔位



平尾控制钢丝尺寸

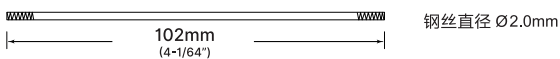

平尾控制钢丝安装孔位



前起落架舱门控制钢丝尺寸



前起落架舱门控制钢丝安装孔位



后起落架舱门控制钢丝尺寸



后起落架舱门控制钢丝安装孔位



减速板控制钢丝尺寸

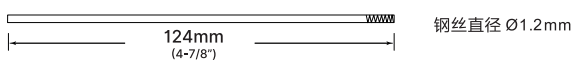

减速板控制钢丝安装孔位



前轮转向控制钢丝尺寸

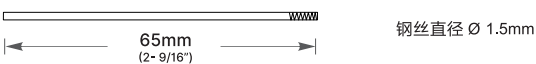

前轮转向控制钢丝安装孔位



重要附加说明:

本产品所使用的“Y”型夹头，均配备了透明硅胶圈进行二次加固，能有效防止夹头意外松开。如下图所示，当您将夹头扣入舵面摇臂后，请使用硅胶圈套住夹头。

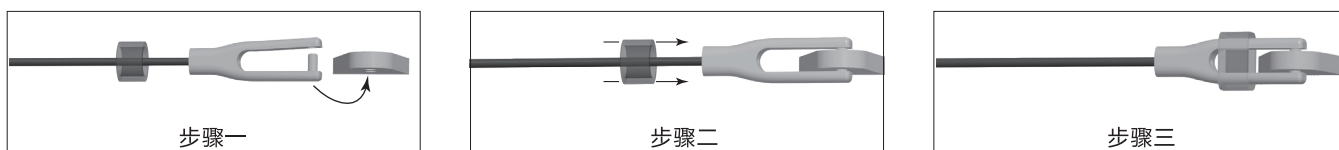

重心示意图

正确的重心，直接关系到飞行的成功与否，请参考下面的重心标示图，来调整飞机的重心。

- 您可以将电池向前，或者向后移动，来调整飞机的重心；
- 如果通过电池的移动无法调整到正确的重心位置，您还可以适当的使用一些其它材料来配重，使飞机的重心处于正确的位置！

如图所示,在机身下表面表面已经雕刻了重心位置标记.请根据此标示线来确认重心.如果标记模糊不清,那么请根据图示尺寸测量。

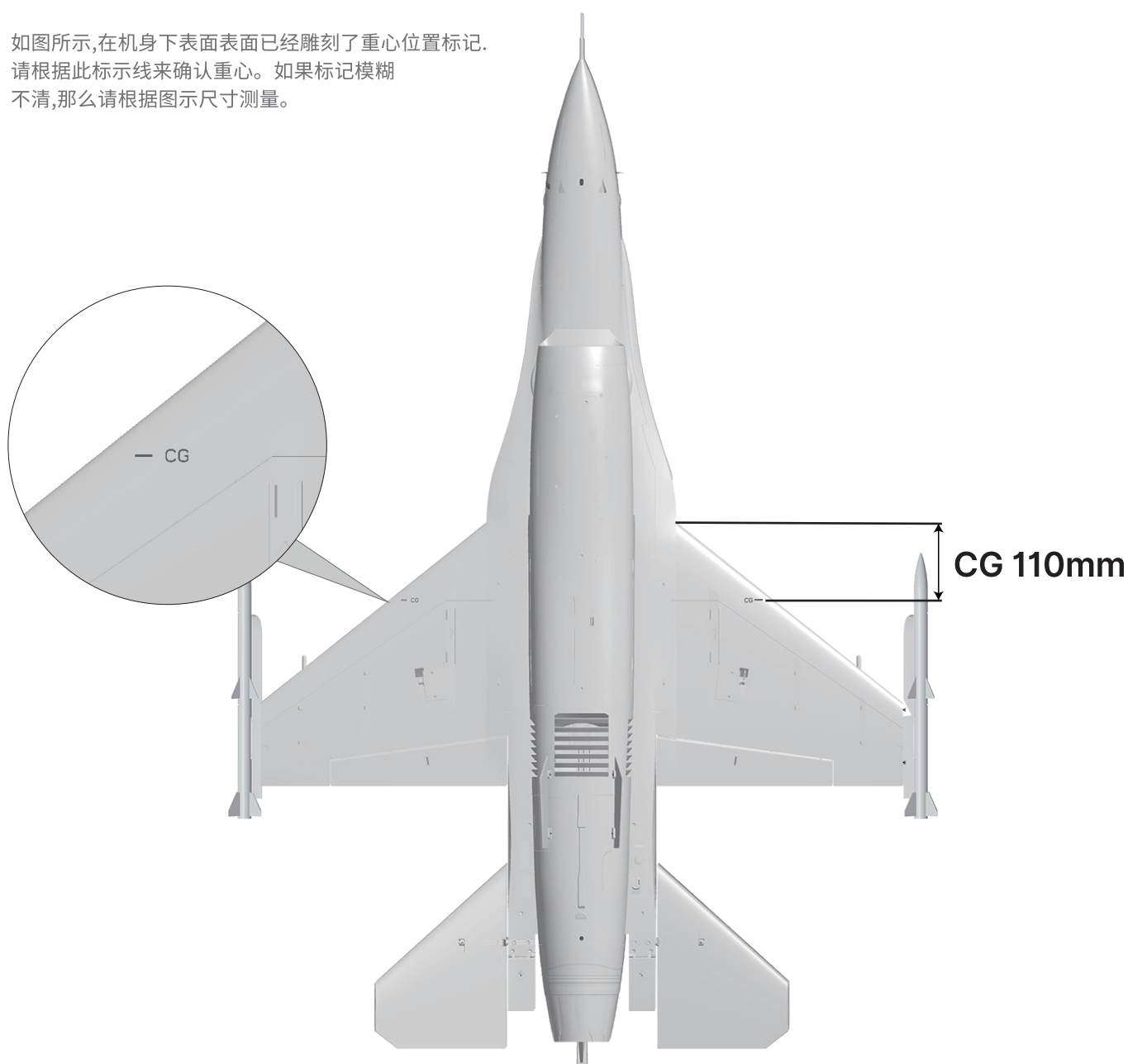

当您组装好飞机后，请连接接收机并通电，对飞机进行调试。

1. 在遥控器所有通道微调归零、操纵杆居中的情况下:检查飞机上每一个舵面是否处于居中位置，如发现舵面未处于居中位置，请通过调整操纵钢丝使其居中；
2. 请参考下面示意图，通过遥控器来测试飞机的每个舵面，确保其运动方向与下列示意图相符。如果出现相反的运动动作，首先请查看遥控器中，相关通道是否开启了反向功能；若问题持续存在，请联系我们协助解决。

副翼

副翼摇杆
向左运动

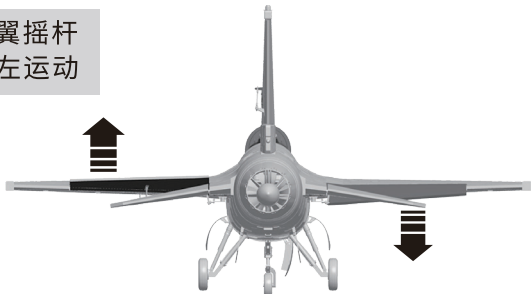

副翼摇杆
向右运动



方向舵

方向摇杆
向左运动



方向摇杆
向右运动



升降舵

升降摇杆
向下运动

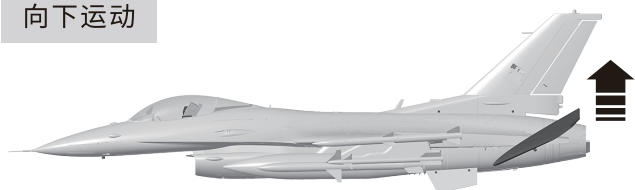

升降摇杆
向上运动

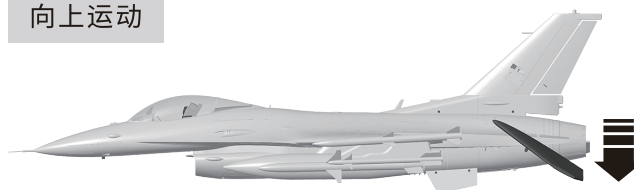

遥控器EXP设置建议

1.副翼EXP曲线如下图:

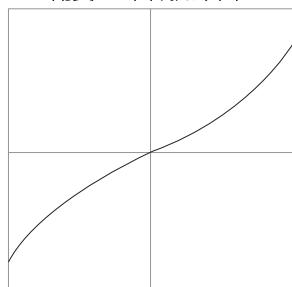

Futaba系列遥控器: EXP A -30
EXP B -30

Spektrum系列遥控器: EXPO 30% 30%

2.升降舵EXP曲线如下图:

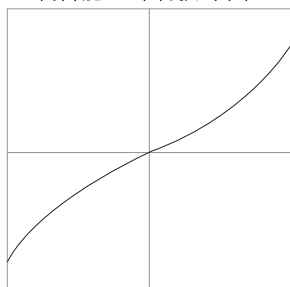

Futaba系列遥控器: EXP A -30
EXP B -30

Spektrum系列遥控器: EXPO 30% 30%

3.方向舵EXP曲线如下图:

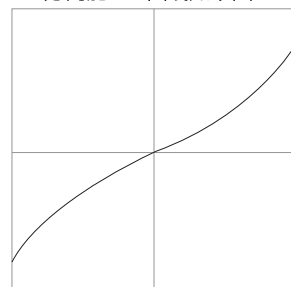

Futaba系列遥控器: EXP A -30
EXP B -30

Spektrum系列遥控器: EXPO 30% 30%

大、小舵参数

根据我们的测试经验，我们认为，按以下参数来设置大小舵量，将有助于飞行，舵量越大，模型飞机的动作响应更快，动作幅度可以更大。我们建议初次飞行使用大舵量起飞，然后根据个人情况调整到适合您的舵量。

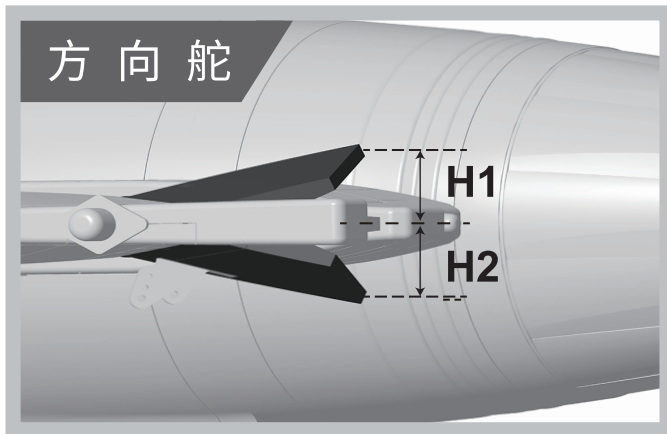
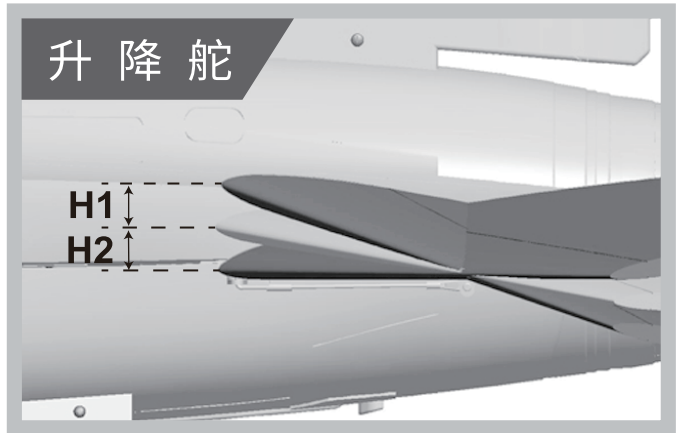
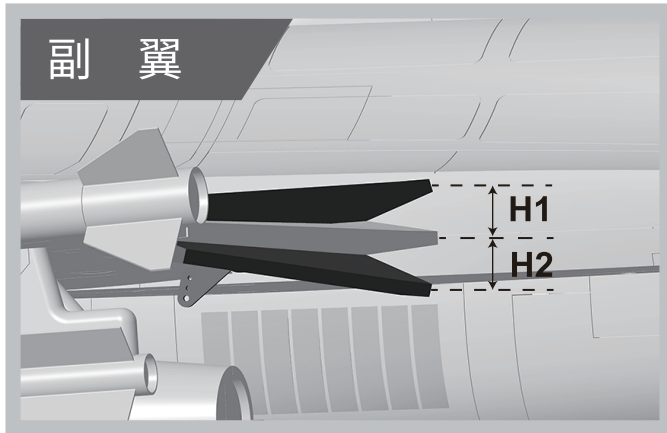

	副翼 (内侧)	升降舵 (前点)	方向舵 (下侧)
小舵量	H1/H2 28mm/28mm 舵量比率: 80%	H1/H2 28mm/28mm 舵量比率: 80%	H1/H2 24mm/24mm 舵量比率: 80%
大舵量	H1/H2 35mm/35mm 舵量比率: 100%	H1/H2 33mm/33mm 舵量比率: 100%	H1/H2 29mm/29mm 舵量比率: 100%

平尾居中位置

1. 请参考右图，将平尾调整到正确的居中位置。

平尾翼根前缘 (最前端位置) 距机身上表面:19mm



舵机使用介绍

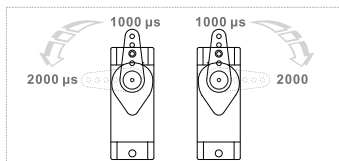

我们的舵机正、反向标准是：
当舵机输入信号从 1000µs 到 2000 时，
如果舵机摇臂，
顺时针旋转---正向舵机
逆时针旋转---反向舵机

如果您需要选购其它品牌的舵机进行安装，
请参考下面的表格选择的舵机

舵机位置	舵机规格	序号	方向性	线长
前轮转向	9g混合	1	正向	200mm
前起落架舱门	9g混合	2	反向	200mm
后起落架舱门(左)	9g混合	3	正向	200mm
后起落架舱门(右)	9g混合	4	反向	200mm
副翼(左)	17g金属	5	正向	200mm
副翼(右)	17g金属	6	正向	200mm
垂尾	17g金属	7	正向	200mm
平尾(左)	23g金属	8	正向	100mm
平尾(右)	23g金属	9	反向	100mm
减速板(左)	9g混合	10	正向	100mm
减速板(右)	9g混合	11	反向	100mm

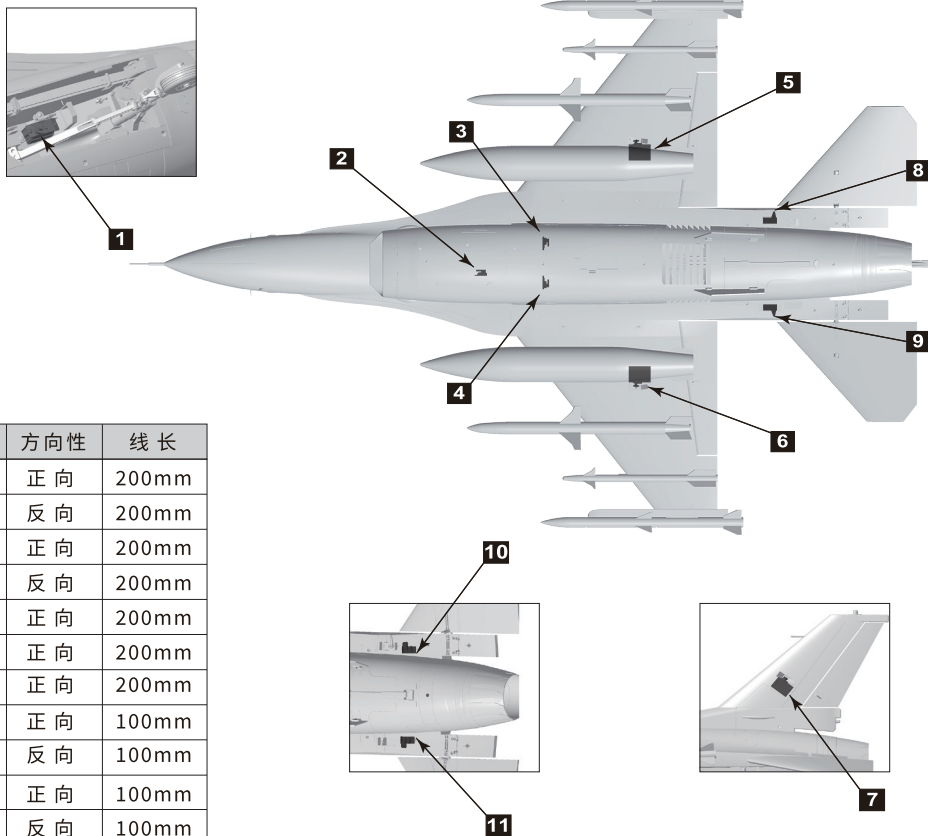

电机参数

3668-1960
Item No.:MI036881

单位: 毫米(mm)

6S

3668-1960KV

动力组编号	涵道类型	电压(V)	电流(A)	最大功率(W)	推力(g)	效率比(g/w)	电机规格(KV)	使用电调(A)	重量(g)
E72216	90涵道(12叶)	22.2	120	2660	3700	1.4	3668-1960	120	454

Item No.:MI040754
4075-1350kv

单位: 毫米(mm)

8S

动力组编号	涵道类型	电压(V)	电流(A)	最大功率(W)	推力(g)	效率比(g/w)	电机规格(KV)	使用电调(A)	重量(g)
E72215	90涵道(12叶)	29.6	115	3400	4700	1.39	M1040754 4075-1350KV	120	558



Dongguan Freewing Electronic Technology Ltd
HK Freewing Model International Limited

Add.: FeiYi Building, 402-408#, Fumin Middle Road, Dalang Town,
Dongguan City, Guangdong Province, China

Web: <http://www.sz-freewing.com> www.freewingmodel.com

Email: freewing@sz-freewing.com

Tel: 86-769-82669669 Fax: 86-769-82033233

东莞市飞翼电子科技有限公司
香港飞翼模型国际有限公司

地址: 广东省东莞市大朗镇富民中路402-408号飞翼楼四楼

Web: <http://www.sz-freewing.com> www.freewingmodel.com

Email: freewing@sz-freewing.com

Tel: 86-769-82669669 Fax: 86-769-82033233

