

# F-22 Raptor

## USER MANUAL

**Wingspan:1060mm (41.7 in)**  
**Length:1500mm (59 in)**  
**Empty Weight: 2960g (w/o Battery)**



1	Introduction
1	Note
2	Product basic information
2	Package list
	<b>PNP Assembly Instructions</b>
3	Install vertical tail
3	Install horizontal tail
3	Install main wing
4	Install small plastic parts
4	Pushrod instructions
	<b>Control Setup Instructions</b>
5	Battery Size
5	Center of Gravity
6	Control Direction Test
7	Dual Rates
7	Important Flight Notes
	<b>Pre-Installed Component Overview</b>
8	Servo Direction
8	Motor Specification
	<b>前言</b>
9	重要提示
10	产品基本参数
10	产品包装清单
	<b>PNP组装说明</b>
11	垂尾组装
11	平尾组装
11	主翼组装
12	仿真小配件
12	舵面钢丝尺寸
	<b>调校及设定</b>
13	电池安装说明
13	重心示意图
14	舵面测试
15	大小舵参数
15	混控及平尾设定
	<b>舵机及电机参数</b>
16	舵机规格介绍
16	电机规格介绍

Thank you for purchasing our Freewing 90mm EDF Super Scale Jet, the F-22 Raptor! The F-22 is the world's first and features cutting edge advances such as stealth capabilities, enhanced agility and computer controlled maneuverability, and precision weapon combat capabilities. The F-22 represents the future of modern air combat, and its technology continues to set the standard against which all other Fifth Generation fighters are judged.

The Freewing F-22 is a flying foam RC replica of this innovative fighter jet. The Freewing F-22 is 1500mm in length, with a wingspan of 1060mm. Assembled from an array of materials including EPO foam, aluminum, carbon fiber, and other parts, the Freewing F-22 is capable of extreme maneuvers and extended durability on grass runways. The model aircraft features highly detailed surface detailing and paintwork and decals, to accentuate the muted but complex surface seen on the full-size F-22. Assembly is completed primarily with screws to attach the flying surfaces. The main wings disconnect conveniently with a flexible ribbon wire cable, which smartly reduces the load exerted on the actual electronic connections.

The Freewing F-22 is available in two PNP versions. The Standard version features a 90mm EDF with an all-new 9 blade single piece impeller, factory balanced for precise operation, paired with a 3748-1750KV outrunner brushless motor and 130A ESC. The Deluxe version features a 90mm 12 blade impeller, also molded as a single unit and factory balanced, mounted to a powerful 4075-1390KV outrunner brushless motor and 150A ESC. The F-22's maximum level airspeed has been measured at 170KPH / 106MPH and 190KPH / 119MPH between the Standard and Deluxe versions, respectively.

The Freewing F-22 has been optimized for operation on paved runways and also short grass runways. Even without flaps, the model can takeoff in less than 30 meters. A widened gear stance and larger grass-appropriate wheels greatly improve ground handling. In the flight pattern, the F-22 truly shines. It is highly maneuverable and difficult to stall, and can be flown at high angles of attack including high-alpha passes, inverted Immelmans, etc. In the landing pattern, flaps are not required to slow the model to a long and level descent. If flaps are desired, we recommend mixing slight down elevator to avoid a nose-high approach.

Overall the Freewing 90mm F-22 is a very approachable flyer and suitable for pilots moving up from 80mm to their first 90mm jet.

## Note

1. This is not a toy! Operator should have a certain experience, beginners should operate under the guidance of professional players.
2. Before install, please read through the instructions carefully and operate strictly under instructions.
3. Cause of wrong operation, Freewing and its vendors will not be held responsible for any losses.
4. Model planes' players must be on the age of 14 years old.
5. This plane used the EPO material with surface spray paint, don't use chemical to clean, otherwise it will damage.
6. You should be careful to avoid flying in areas such as public places, high-voltage-intensive areas, near the highway, near the airport or any other place where laws and regulation clearly prohibit.
7. You cannot fly in bad weather conditions such as thunderstorms, snows....
8. Model plane's battery, don't allowed to put in everywhere. Storage must ensure that there is no inflammable and explosive materials in the round of 2M range.
9. Damaged or scrap battery should be properly recycled, it can't discard to avoid spontaneous combustion and fire.
10. In flying field, the waste after flying should be properly handled, it can't be abandoned or burned.
11. In any case, you must ensure that the throttle is in the low position and transmitter switch on, then it can connect the lipo-battery in aircraft.
12. Do not try to take planes by hand when flying or slow landing process. You must wait for landing stop, then carry it.

**⚠ Warning:** This is not a toy! Not for children under 14 years. Young people under the age of 14 should only be permitted to operate this model under the instruction and supervision of an adult. Please keep these instructions for further reference after completing model assembly.

## Product basic information

EN

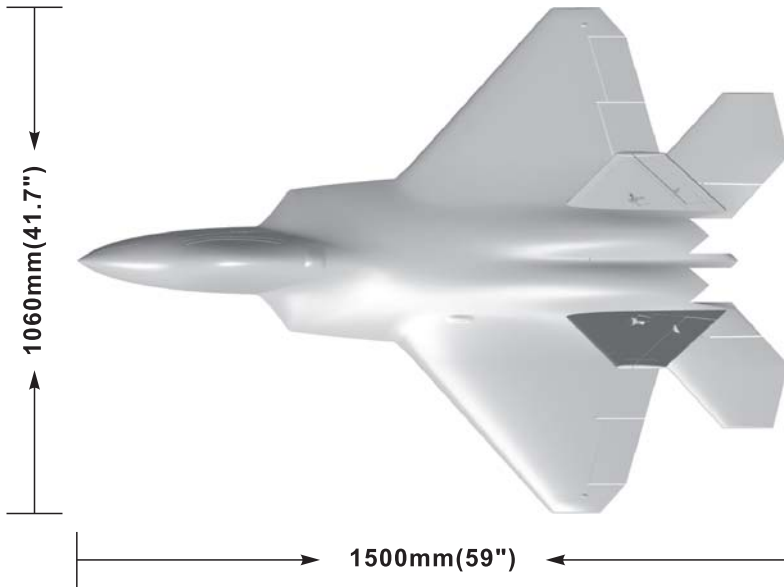

Wingloading: 142g/dm<sup>2</sup>  
 Wing area : 26 dm<sup>2</sup>  
 Servo: 9g digital MG (2pcs)  
 17g digital MG (8pcs)

### 6S Standard Version

Motor: 3748-1750KV O/R brushless motor  
 Ducted fan: 90mm 9-Blade plastic fan  
 ESC: 130A ESC with 8A UBEC  
 Empty weight: 2960g (w/o battery)  
 Thrust: 4000g

### 8S Deluxe Version

Motor: 4075-1390KV I/R brushless motor  
 Ducted fan: 90mm 12-Blade plastic fan  
 ESC: 150A ESC with 5A UBEC  
 Empty weight: 3230g (w/o battery)  
 Thrust: 5200g

### Features

EPO material with plastic parts  
 Electric retracts and trailing link suspension struts  
 Magnetic removable nose cone with plastic cap  
 Spring-hinged double nose door  
 Nose landing gear Led light  
 Scale pilot (1pcs)

**Note:** The parameters in here are derived from test result using our accessories. If use other accessories, the test result will be different. Any problem since of using other accessories, we are not able to provide technical support.

## Package list



No.	Name	PNP	ARF Plus	Airframe
1	Fuselage	Pre-installed all electronic parts	Pre-installed servo	No electronic equipment
2	Main wing	Pre-installed all electronic parts	Pre-installed servo	No electronic equipment
3	Horizontal tail	✓	✓	✓
4	Vertical tail	Pre-installed all electronic parts	Pre-installed servo	No electronic equipment
5	Nose cone	✓	✓	✓
6	MCB-E	✓	✓	✓

No.	Name	PNP	ARF Plus	Airframe
7	Carbon tube	✓	✓	✓
8	Pushrod	✓	✓	✓
9	Non-slip mat	✓	✓	✓
10	Glue	✓	✓	✓
11	Manual	✓	✓	✓
12	Screw	✓	✓	✓

## Install vertical tail

Assemble left and right Vertical stabilizer as the right photo show:

Step 1

A- Screw (KA3x10mm 4pcs)

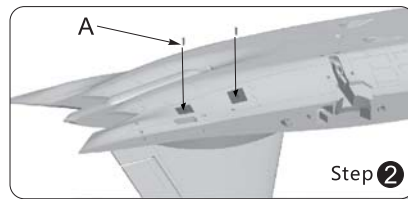

Step 2

## Install horizontal tail

1. Use metal fixed ring to fix the rotating shaft.
2. Insert the rotating shaft to the fuselage and use screw to fix.

A- Screw (PM2x4mm 2pcs)  
 B- metal fixed ring  
 C- Rotating shaft  
 D- Screw (PT3x10mm 4pcs)  
 E- Washer

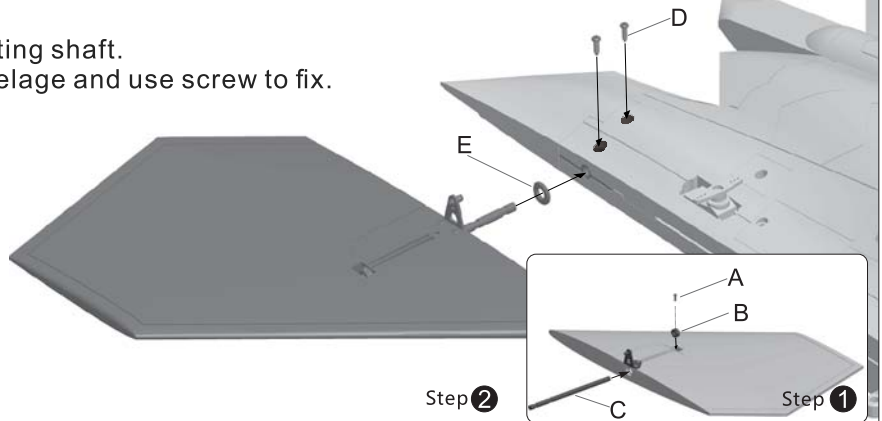

Step 2

Step 1

## Install main wing

Carbon tube  
 (Ø10x650mm)

Step 1

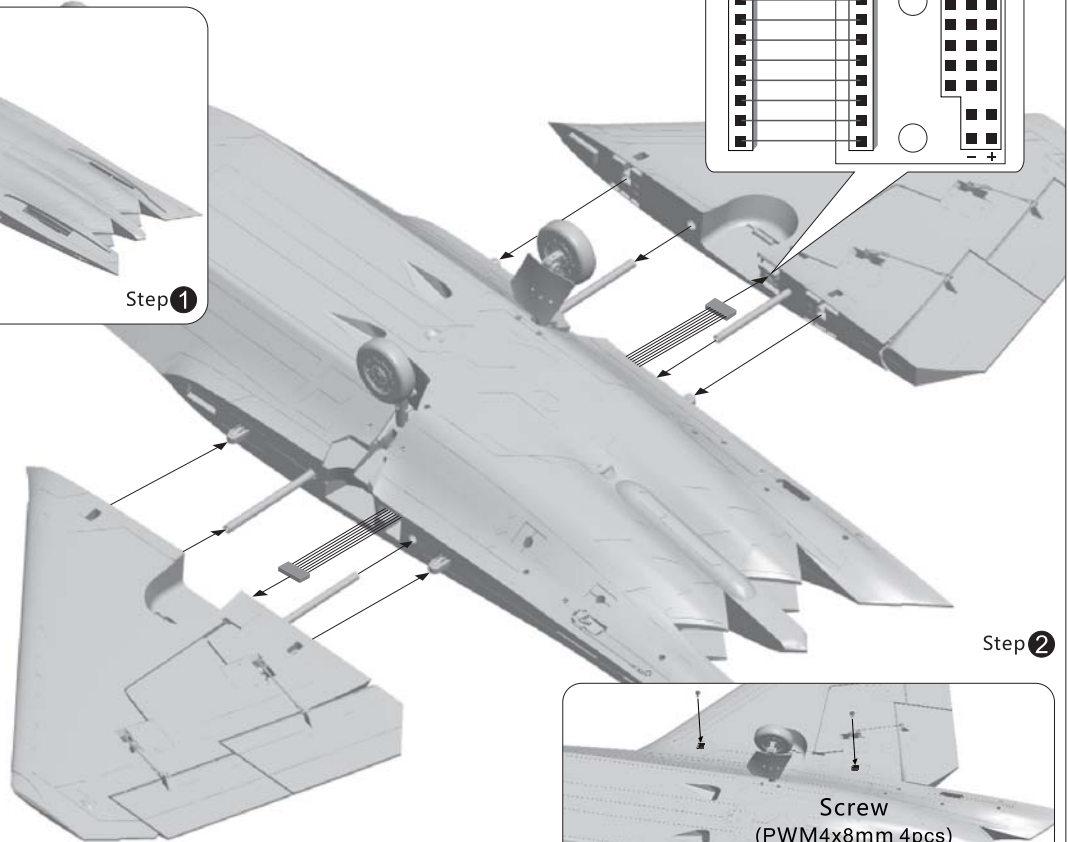
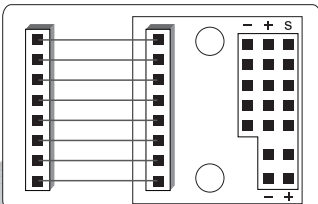

Step 2

1. At the first, put down the landing gear.
2. Insert the carbon tube to the fuselage and keep it in the center.
3. Insert the ribbon wire to the main wing control board, close the wing and fix it with screws.

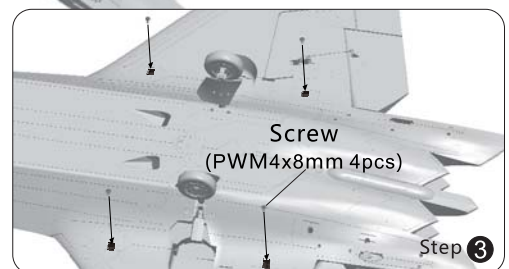

Step 3

## Install small plastic parts

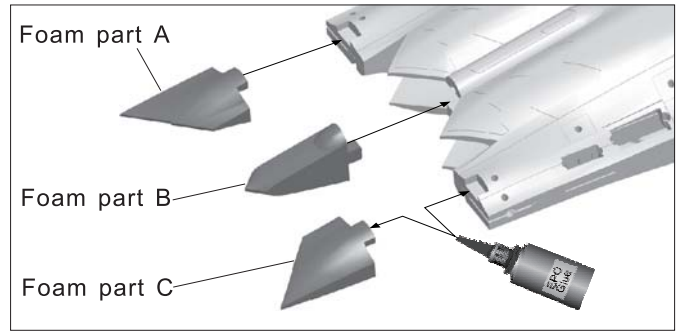
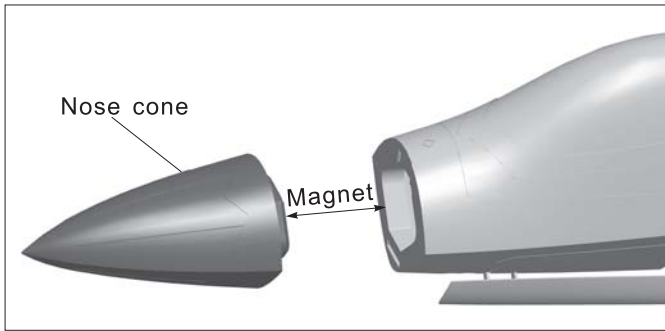

## Pushrod instructions

### Nose steering pushrod size

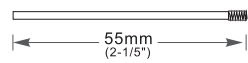

Pushrod diameter : Ø 1.2mm

### Servo pushrod installing hole



### Flap pushrod length

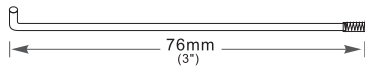

Pushrod diameter : Ø 1.5mm

### Flap pushrod mounting hole



### Aileron pushrod length

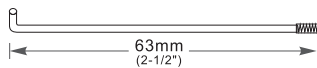

Pushrod diameter : Ø 1.5mm

### Aileron pushrod mounting hole



### Elevator pushrod length

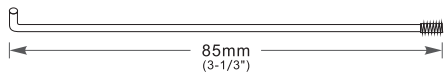

Pushrod diameter : Ø 1.5mm

### Elevator pushrod mounting hole



### Rudder pushrod length

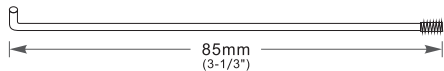

Pushrod diameter : Ø 1.5mm

### Rudder pushrod mounting hole





## Battery Size

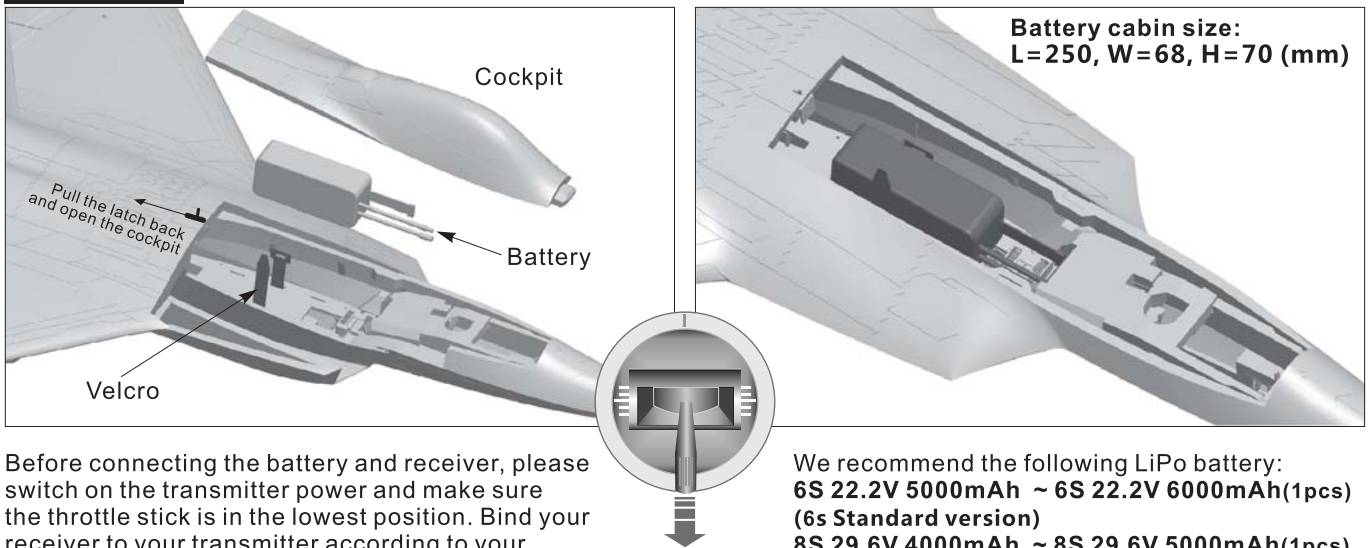

Before connecting the battery and receiver, please switch on the transmitter power and make sure the throttle stick is in the lowest position. Bind your receiver to your transmitter according to your transmitter's instruction manual.

We recommend the following LiPo battery:  
**6S 22.2V 5000mAh ~ 6S 22.2V 6000mAh(1pcs)**  
**(6s Standard version)**  
**8S 29.6V 4000mAh ~ 8S 29.6V 5000mAh(1pcs)**  
**(8s Deluxe version)**  
**Discharge rate of C ≥ 35C**

## Center of Gravity

Correct Center of Gravity is critical for enabling safe aircraft stability and responsive control. Please refer to the following CG diagram to adjust your aircraft's Center of Gravity.

- Depending on the capacity and weight of your chosen flight batteries, move the battery forward or backward to adjust the Center of Gravity.
- If you cannot obtain the recommended CG by moving the battery to a suitable location, you can also install a counterweight to achieve correct CG. However, with the recommended battery size, a counterweight is not required. We recommend flying without unnecessary counterweight.

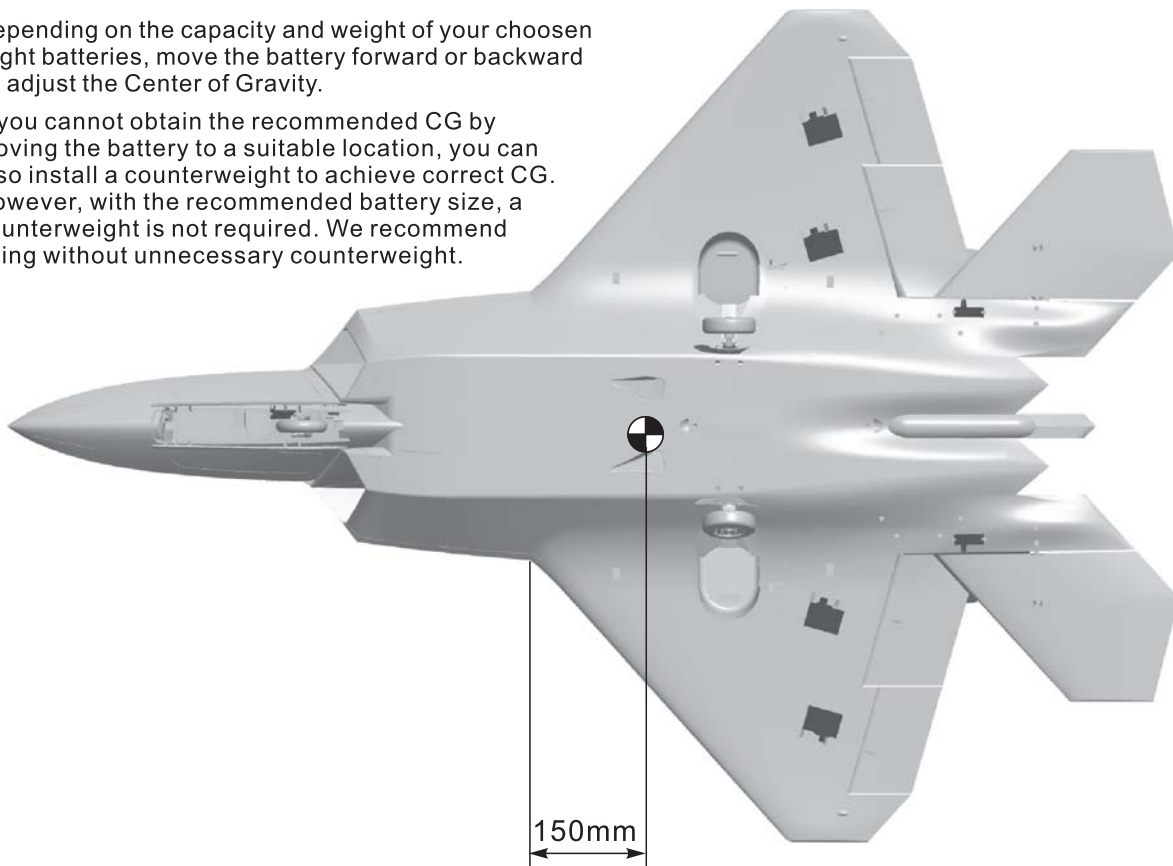

## Control Direction Test

After installed the plane, before flying, we need a fully charged battery and connect to the ESC, then use radio to test and check that every control surface work properly.

### Aileron

Stick Left



Stick Right



### Elevator

Stick down



Stick Up

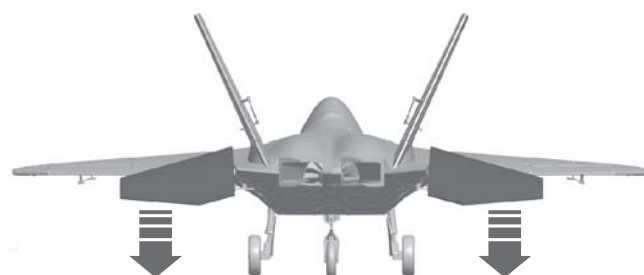

### Rudder

Stick Left



Stick Right



### Flaps

Flaps down

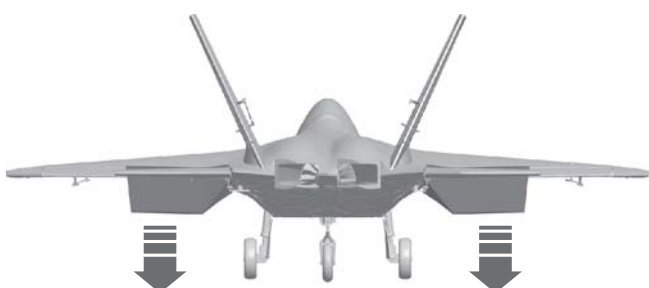



## Dual Rates

According to our testing experience, use the following parameters to set Aileron/Elevator Rate. Program your preferred Exponential % in your radio transmitter. We recommend using High Rate for the first flight, and switching to Low Rate if you desire a lower sensitivity. On successive flights, adjust the Rates and Expo to suit your preference.

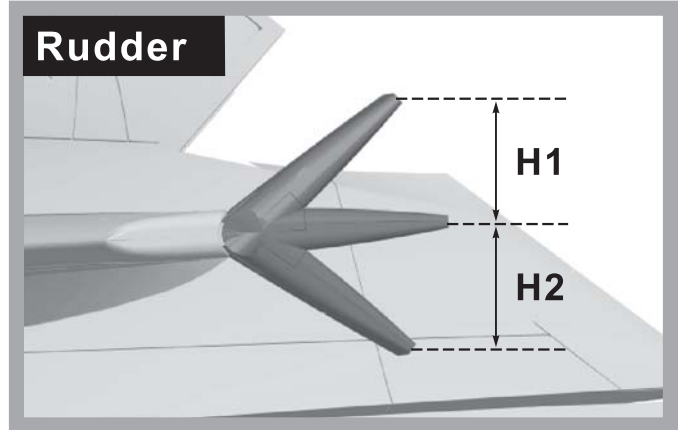
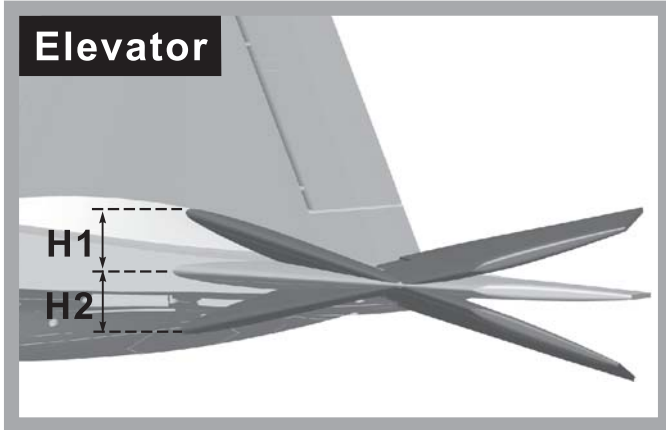
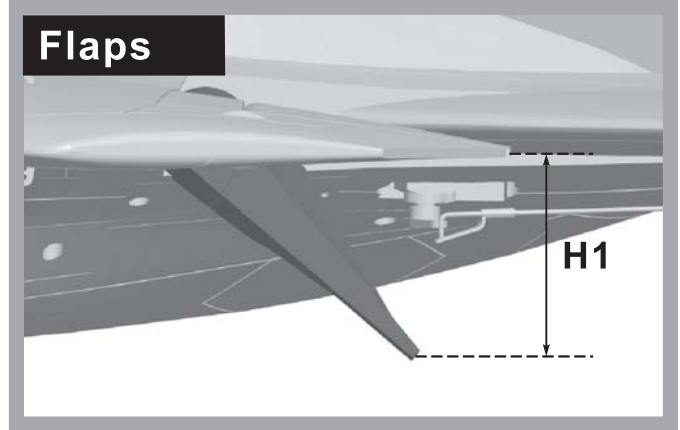
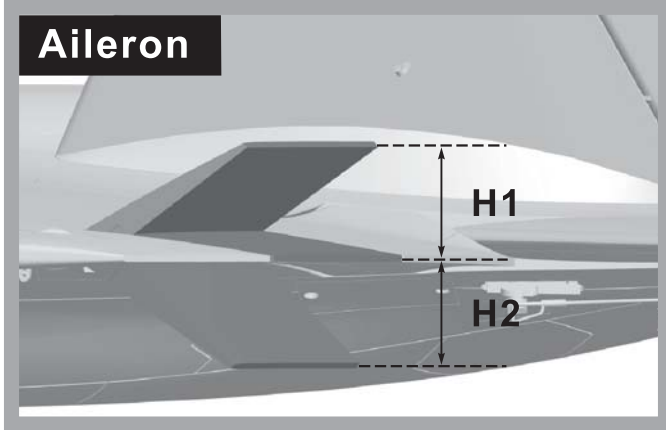

	Aileron(measured closest to the fuselage)	Elevator(measured closest to the fuselage)	Rudder(Measured from the bottom)	Flaps
<b>Low Rate</b>	H1/H2 28mm/28mm D/R Rate : 80%	H1/H2 27mm/27mm D/R Rate : 60%	H1/H2 26mm/26mm D/R Rate : 80%	H1 22mm
<b>High Rate</b>	H1/H2 32mm/32mm D/R Rate : 100%	H1/H2 35mm/35mm D/R Rate : 80%	H1/H2 32mm/32mm D/R Rate : 100%	H1 32mm

### ⚠ Important Flight Notes:

A Flap-to-Elevator Mix is required to maintain level flight when the flaps are deployed. The detail is as below:

With high rate flaps deployed, mix 2mm of **DOWN** elevator.

With low rate flaps deployed, mix 1mm of **DOWN** elevator.

**Please confirm your horizontal tail position is correct as the right photo show.**

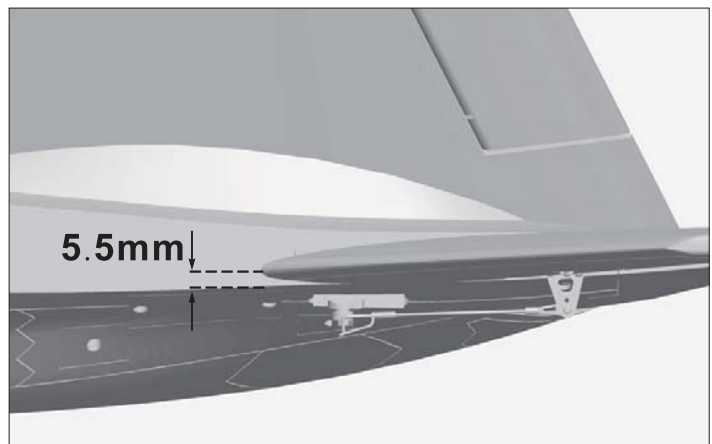

## Servo Direction

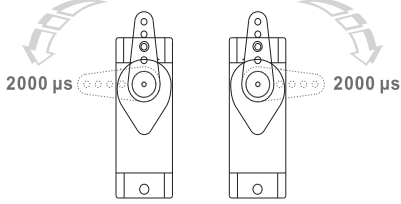

The servo positive or reverse rotation is defined as follows:  
 When servo input signal change from 1000μs to 2000μs,  
 The servo arm is rotated clockwise, its positive servo.  
 The servo arm is rotated counterclockwise, its reverse servo.

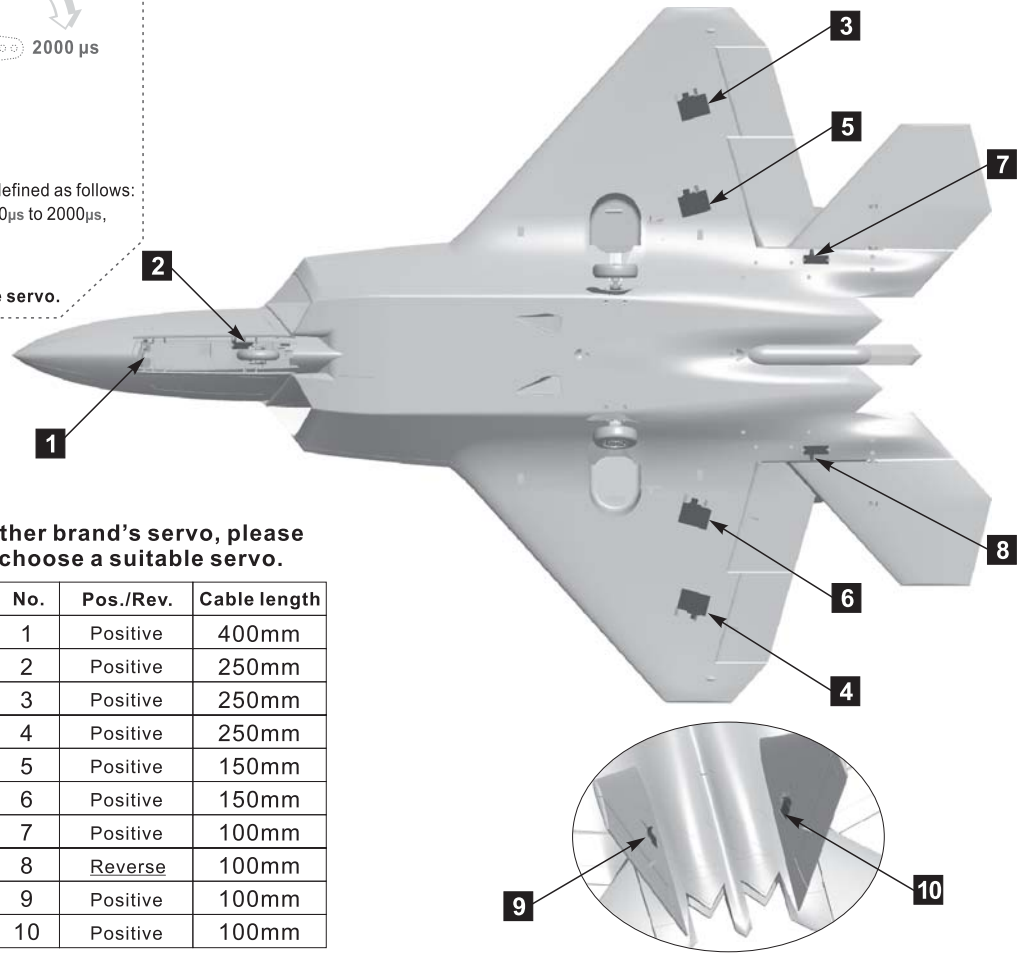

If you need to purchase another brand's servo, please refer to the following list to choose a suitable servo.

Position	Servo type	No.	Pos./Rev.	Cable length
Nose door	9g MG-Digital	1	Positive	400mm
Nose gear steering servo	9g MG-Digital	2	Positive	250mm
Aileron(L)	17g MG-Digital	3	Positive	250mm
Aileron(R)	17g MG-Digital	4	Positive	250mm
Flap(L)	17g MG-Digital	5	Positive	150mm
Flap(R)	17g MG-Digital	6	Positive	150mm
Elevator(L)	17g MG-Digital	7	Positive	100mm
Elevator(R)	17g MG-Digital	8	Reverse	100mm
Rudder(L)	17g MG-Digital	9	Positive	100mm
Rudder(R)	17g MG-Digital	10	Positive	100mm

## Motor Specification

Item No.:MO037484  
**3748-1750kv**

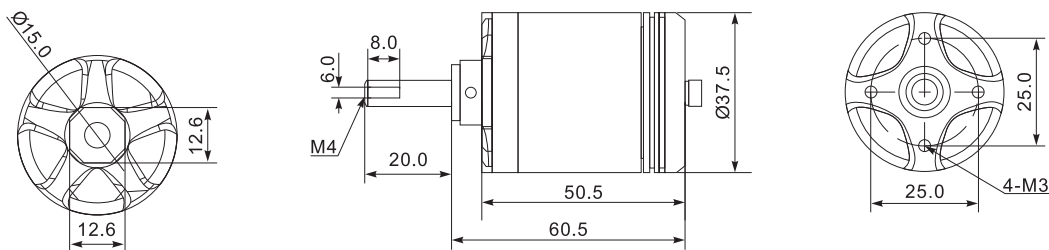

Unit:mm

Item No.:MI040753  
**4075-1390kv**

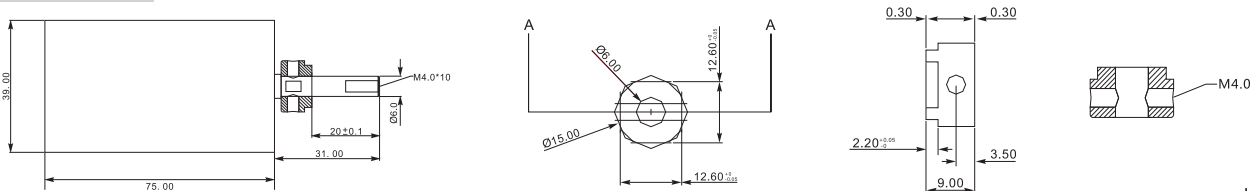

Unit:mm

Item No.	Use motor	Motor(KV)	Thrust(g)	Current(A)	Use voltage (V)	Use ESC (A)	EDF Weight (g)	Max power (W)	Efficiency (g/w)
E7228	<b>MO037484</b> 3748-1750KV	1750	4000	100	22.2(6S)	130	378	2200	1.82
E72211	<b>MI040753</b> 4075-1390KV	1390	5000-5200	95-110	29.6(8S)	150	580	3000	1.7



**Dongguan Freewing Electronic Technology Ltd**  
**HK Freewing Model International Limited**

Add.: Fei Yi Building, face to Labor Bureau, Fumin Middle Road, Dalang Town,  
Dongguan City, Guangdong Province, China

Web: <http://www.sz-freewing.com>

Email: [freewing@sz-freewing.com](mailto:freewing@sz-freewing.com)

Tel: 86-769-82669669 Fax: 86-769-82033233

**东莞市飞翼电子科技有限公司**  
**香港飞翼模型国际有限公司**

地址: 广东省东莞市大朗镇富民中路402-408号飞翼楼四楼

Web: <http://www.sz-freewing.com>

Email: [freewing@sz-freewing.com](mailto:freewing@sz-freewing.com)

Tel: 86-769-82669669 Fax: 86-769-82033233



**Motion RC B.V.**  
Keulschevaart 11  
3621 MX Breukelen  
Netherlands

Made in China