

# KAVAN Pulse 2200 V2 - Instruction manual

## INTRODUCTION

Congratulations on your purchase of the **Pulse 2200 V2**, motor-powered glider. You are about to start assembling a model manufactured from virtually unbreakable EPO (expanded polyolefin) foam powered by a mighty brushless motor and lightweight LiPo battery. Everybody who has already mastered flying a "full house" trainer – with aileron, elevator, rudder, and throttle control will enjoy this beautiful high-performance glider.

However, if you have not flown any other RC model yet, please put your Pulse 2200 V2 aside for a while – at least until you become familiar with any of the trainers like KAVAN BETA 1400 or ALPHA 1500. You can purchase any of these planes as RTF or ARTF kits. Please note that even the most famous glider pilots started their careers flying an elementary trainer first. After a lot of hours at the controls of a twin-seater (like the famous Czech L-13/23 Blanik) they had made their first solo flight and only then they could fly all those high-performance gliders.



**KAV02.8091 KAVAN Pulse 2200 V2 - orange** |  
**KAV02.8092 KAVAN Pulse 2200 V2 - green**

## BEFORE YOU START

1. If you are not an experienced RC pilot, plan to have a fully competent pilot check your completed model and help you with your first flights. Even though we have tried to provide you with a thorough instruction manual, RC models are rather complicated. An experienced modeller can quickly check over your model to make sure your first flights are successful.
2. Please assemble your model exactly according to these instructions. Do not attempt to modify or change your model in any way as doing so may adversely change its flying characteristics.
3. Before you begin, please check the entire contents of this kit to make sure no parts are missing or damaged. This will also help you to become familiar with each component of your plane. If you find that any of the parts are either missing or damaged, please contact your dealer immediately for replacement.

**Note:** Your dealer cannot accept kits for return if construction has begun.

4. Trial fit each part before glueing it in place. Make sure you are using the correct part, and that it fits well before assembling. No amount of glue can make up for a poorly fitting part.
5. The manual contains a drawing showing the default position of the Centre of Gravity (CG) and recommended control surface throws. Please note it is essential to keep the recommended CG position for the first flight otherwise the model could be unstable, hard to control or even unable to fly at all. Later you can fine-tune the CG position to suit your flying style and skills.

## PRECAUTIONS

**This RC model is not a toy. Use it with care and strictly following the instructions in this manual.**

Assemble this model following strictly these instructions. DO NOT modify or alter the model. Failure to do so, the warranty will lapse automatically. Follow the instructions to obtain a safe and solid model at the end of the assembly.

Children under the age of 14 must operate the model under the supervision of an adult. Assure that the model is in perfect condition before every flight, taking care that all the equipment works correctly and that the model is undamaged in its structure.

Fly only on days with a light breeze and in a safe place away from any obstacles.

## SAFETY PRECAUTIONS AND WARNINGS

- An RC aeroplane is not a toy! If misused, it can cause serious bodily harm and damage to property. Fly only in a safe place following all instructions and recommendations in this manual. Beware of the propeller! Keep loose items that can

get entangled in the propeller away from the spinning propeller, including loose clothing, or other objects such as pencils and screwdrivers. Ensure that your and other people's hands, and faces are kept away from the rotating propeller.

- As the user of this product, you are solely responsible for operating it in a manner that does not endanger yourself and others or result in damage to the product or the property of others. This model is controlled by a radio signal that is subject to interference from many sources outside your control. This interference can cause momentary loss of control so it is advisable to always keep a safe distance in all directions around your model, as this margin will help to avoid collisions or injury.
- Never operate your model with low transmitter batteries.
- Always operate your model in an open area away from power lines, cars, traffic or people. Avoid operating your model in populated areas where injury or damage can occur.
- Carefully follow the directions and warnings for this and any optional support equipment (chargers, rechargeable batteries, etc.) which you use.
- Keep all chemicals, small parts and anything electrical out of the reach of children.
- Moisture causes damage to electronics. Avoid water exposure to all equipment not specifically designed and protected for this purpose.
- The model is mostly made of plastics - it is not fireproof. It may not be exposed to higher temperatures otherwise severe distortion of the foam airframe or other damage may occur.

## SPECIFICATION

<b>Wingspan</b>	2206 mm
<b>Length</b>	1266 mm
<b>Wing area</b>	41.8 dm <sup>2</sup>
<b>Weight</b>	1800 g
<b>All-up weight</b>	2100–2250 g
<b>Motor</b>	C3548-750
<b>ESC</b>	KAVAN R–50SB Plus
<b>Propeller</b>	11×8"

## SET CONTENTS

Almost ready-to-fly model of a sailplane with the brushless motor, speed controller and servos installed, instruction manual.

## YOU WILL ALSO NEED

- At least 7-even channel RC set, 14.8 V 2600–4000 mAh LiPo flight pack.
- Regular modeller's tools – modeller's knife, screwdrivers, pliers etc.

## MODEL ASSEMBLY

1. Slide the halves of the horizontal tailplane onto the carbon joiner inserted into the fin. Secure them with four 2.5×8 mm screws. Attach the elevator push rod to the ball link on the elevator horn. **(Fig. 1+2+3)**
2. Connect the wing multi connectors to the corresponding sockets in the wing halves. Insert both the wing halves all the way into the opening in the fuselage until you hear a click. Secure the wing with one M6×40 mm nylon screw. **(Fig. 4+5)**
3. Hook up your receiver, servos and ESC following the wiring diagram **(Fig. 8)**. The receiver is to be secured with a strip of double-sided foam tape or hook-and-loop tape to the rear part of the cockpit. Deploy the antennas, so their active parts are square to each other (if you are using a receiver featuring diversity antennas).
4. The flight pack is to be placed in the bay in the centre of the cockpit; use the installed hook-and-loop ties to fasten it. With your radio on, set the servos to the neutral position (sticks and trims centred) and fasten the setting screws of the pushrod connectors on the elevator and rudder servo arms. Perform the throttle range calibration of the ESC as described in the attachment of this manual. **(Fig. 6)**
5. Attach the canopy.

**Note:** The kit is supplied with the connection board for ailerons, flaps, elevator, rudder servos and the ESC so you can use even the most basic 6-channel radios to control your PULSE 2200 V2. If you intend to use independent control of aileron and flap servos and an advanced computer radio, you will have to bypass the connection board accordingly.

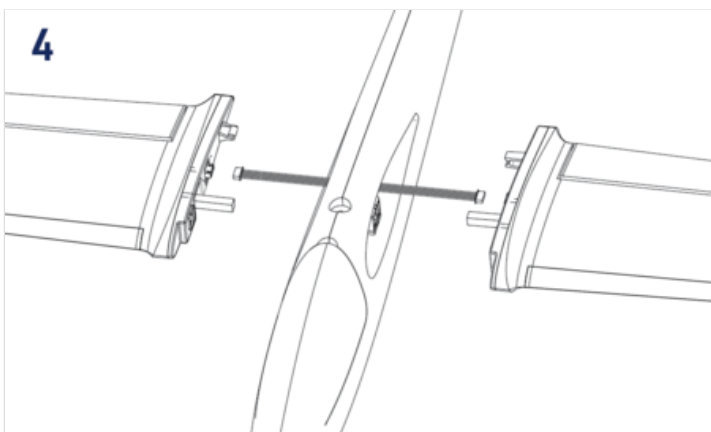
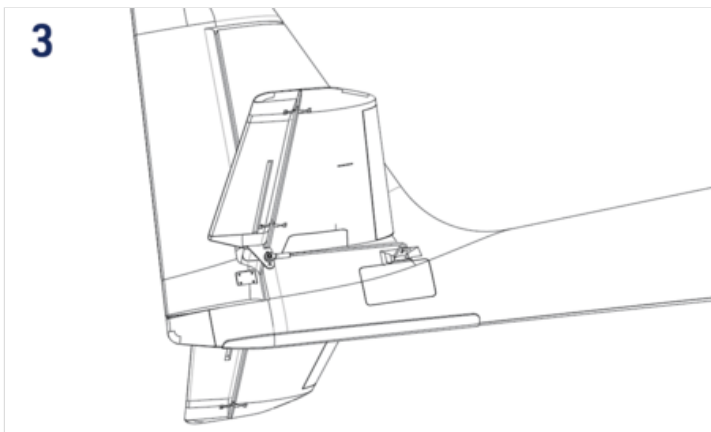
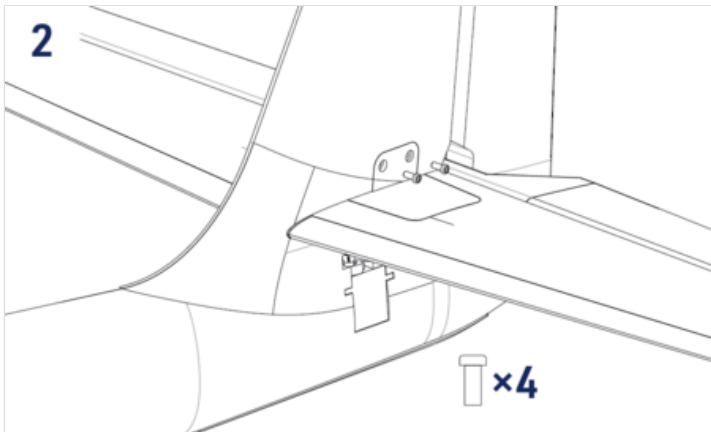
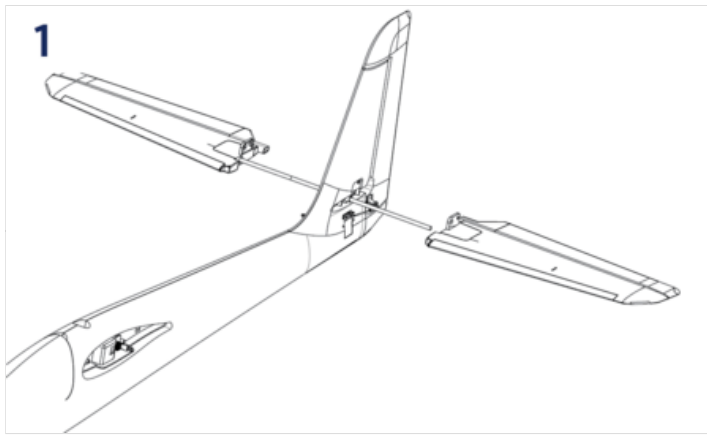

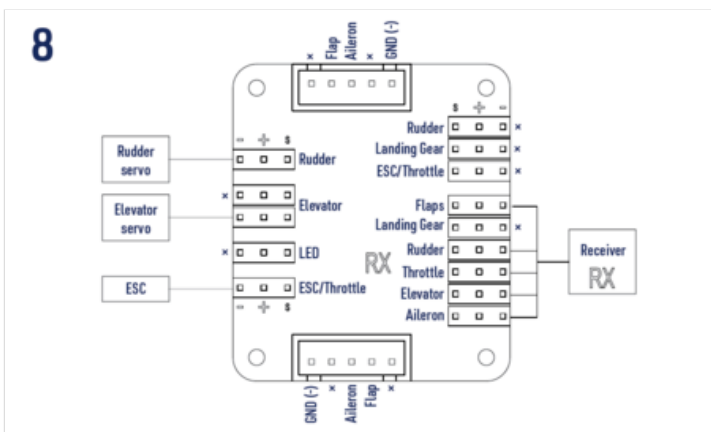
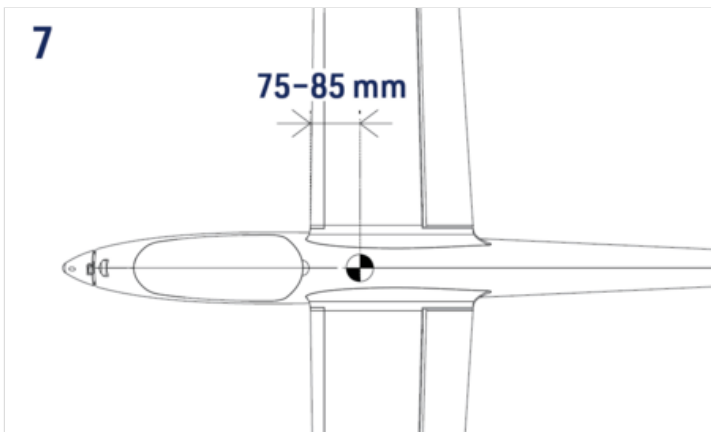
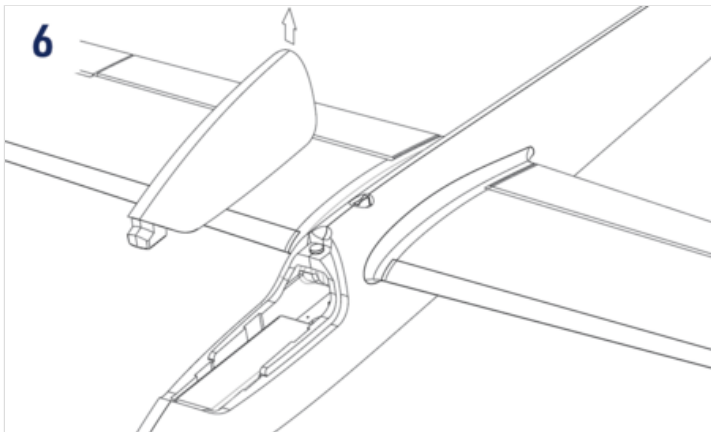
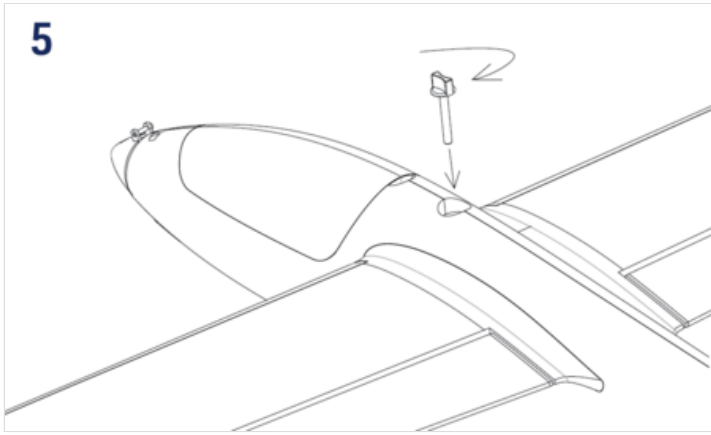

**RC SET INSTALLATION AND PREFLIGHT CHECK**

- Referring to the instruction manual of your radio carefully hook up the onboard electronics.
- Once everything has been correctly connected, turn on your transmitter and plug in the flight pack. Check the neutral positions and throws of all control surfaces. If you need to make the control surface throws smaller, simply move the pushrod closer to the centre on the servo arm or move it far from the control surface on the control horn. And vice versa.

	Low rate	High rate
Ailerons	20 mm up/10 mm down	25 mm up/13 mm down
Ailerons (Butterfly)	20 mm up	20 mm up
Ailerons (Thermal)	3 mm down	3 mm down
Ailerons (Speed)	3 mm up	3 mm up
Elevator	± 10 mm	± 15 mm
Elevator (Butterfly)	1–3 mm down	1–3 mm down
Rudder	± 30 mm	± 40 mm
Flaps	12 mm up/18 mm down	12 mm up/18 mm down
Flaps as Ailerons	7 mm up/3.5 mm down	10 mm up/5 mm down
Flaps (Butterfly)	30 mm down	30 mm down
Flaps (Thermal)	4 mm down	4 mm down
Flaps (Speed)	4 mm up	4 mm up

- The "Low rate" recommended control surface throws are suitable for a less skilled pilot and regular soaring. The "High rate" setting allows an experienced pilot to explore the full aerobatic capabilities of his model. The aileron differential (aileron down deflection reduced to 50 % of up deflection) is only possible with a computer radio.
- Check the direction of rotation of the propeller. If it was incorrect, simply swap any two of the three wires between the ESC and motor or program the ESC (refer to the ESC manual).
- Check the correct position of the centre of gravity (CG) – **75–85 mm** behind the leading edge of the wing (**Fig. 7**). Adjust the CG position by moving the flight pack – if you cannot reach the recommended position, do not hesitate to add an appropriate amount of lead to the nose or tail. An extra couple of grams won't spoil the flying characteristics - but the incorrect CG position is a killer.
- Fully charge your flight pack and transmitter batteries, check the proper function of your radio and perform the range check of your radio according to its instruction manual. The range has to be almost the same with the motor off and at full throttle (no more than a 10 % decrease is acceptable). **DO NOT** try to fly unless the range check is 100% successful.

## FLYING

The test flying and fine-tuning is pretty much straightforward. There will be no surprise for a medium-advanced pilot who is supposed to fly this model.

## APPENDIX

---

### KAVAN R-50SB PLUS INSTRUCTIONS

Please refer to the [KAVAN Plus ESCs - Instruction manual](#).

### RECYCLING AND WASTE DISPOSAL NOTE (EUROPEAN UNION)

Electrical equipment marked with the crossed-out waste bin symbol must not be discarded in the domestic waste; it should be disposed of via the appropriate specialised disposal system. In the countries of the EU (European Union) electrical devices must not be discarded via the normal domestic waste system (WEEE - Waste of Electrical and Electronic Equipment, Directive 2012/19/EU). You can take your unwanted equipment to your nearest public collection point or recycling centre, where it will be disposed of in the proper manner at no charge to you. By disposing of your old equipment in a responsible manner you make an important contribution to the safeguarding of the environment!



## EU DECLARATION OF CONFORMITY (EUROPEAN UNION)

Hereby, KAVAN Europe s.r.o. declares that the model **Pulse 2200 V2** and the included electronic and electric devices are in compliance with the requirements of relevant European directives and harmonized norms. The full text of the Declaration of Conformity is available at [www.kavanrc.com/doc/](http://www.kavanrc.com/doc/).



## GUARANTEE

The KAVAN Europe s.r.o. products are covered by a guarantee that fulfils the currently valid legal requirements in your country. If you wish to make a claim under guarantee, please contact the retailer from whom you first purchased the equipment. The guarantee does not cover faults which were caused in the following ways: crashes, improper use, incorrect connection, reversed polarity, maintenance work carried out late, incorrectly or not at all, or by unauthorised personnel, use of other than genuine KAVAN Europe s.r.o. accessories, modifications or repairs which were not carried out by KAVAN Europe s.r.o. or an authorised KAVAN Europe s.r.o., accidental or deliberate damage, defects caused by normal wear and tear, operation outside the Specification, or in conjunction with equipment made by other manufacturers. Please be sure to read the appropriate information sheets in the product documentation!

---

■